



LARGE WORKSPACE



LARGE BOBBIN

CONSEW[®] Since 1898

Models P1560RB series TWO NEEDLE

Designed for automotive, marine, leather, canvas and general upholstery.

P1560RB-14 / P1560RBL-18 / P1560RBL-25 14" 18" 25"

Plain Machine - Motor, Stand, Table needed.

with

- Large Top Load Bobbin
- Vertical Access Hook
- Built-in Bobbin Winder
- Walking Foot
- Climbing Device
- Reverse
- Semi-Automatic Oiling

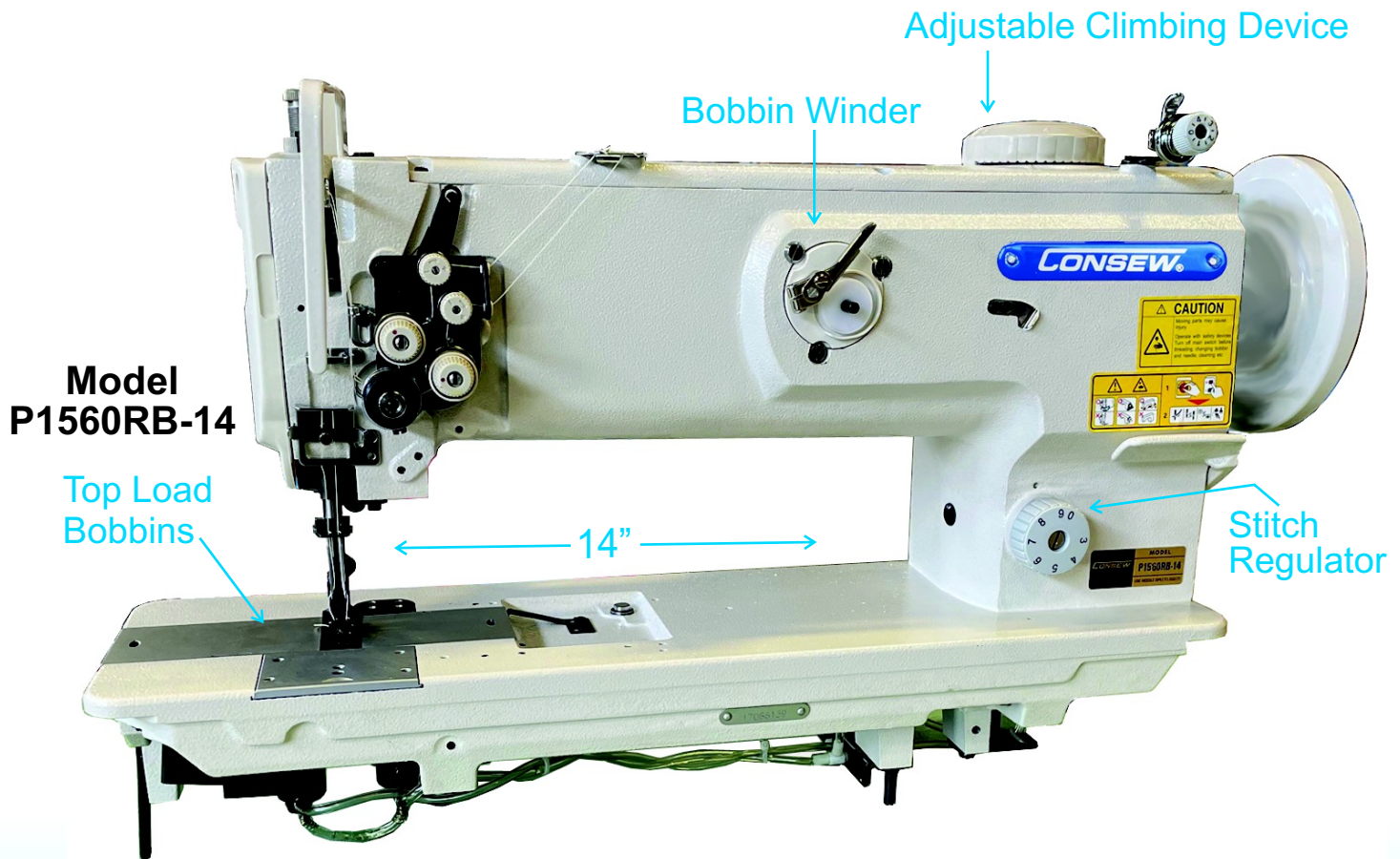

SPECIFICATIONS

Speed, maximum: 2000 - 2500 spm *

Needle: 135 x 17 (DPX17)

1/4" gauge, Largest gauge for regular machines is 1-3/4"

Stitch Length; Max. 9mm Adjustment By Dial

Presser Foot Lift By Hand: 9 mm By Knee: 16mm

Lubrication: Semi-Automatic

Power: 110 or 220 v. 1-Phase

* Speed depends on thread, material and operation.

High Speed Two Needle Walking Foot Lockstitch Machines

TWO NEEDLE

Designed for automotive, marine, leather, canvas and general upholstery.

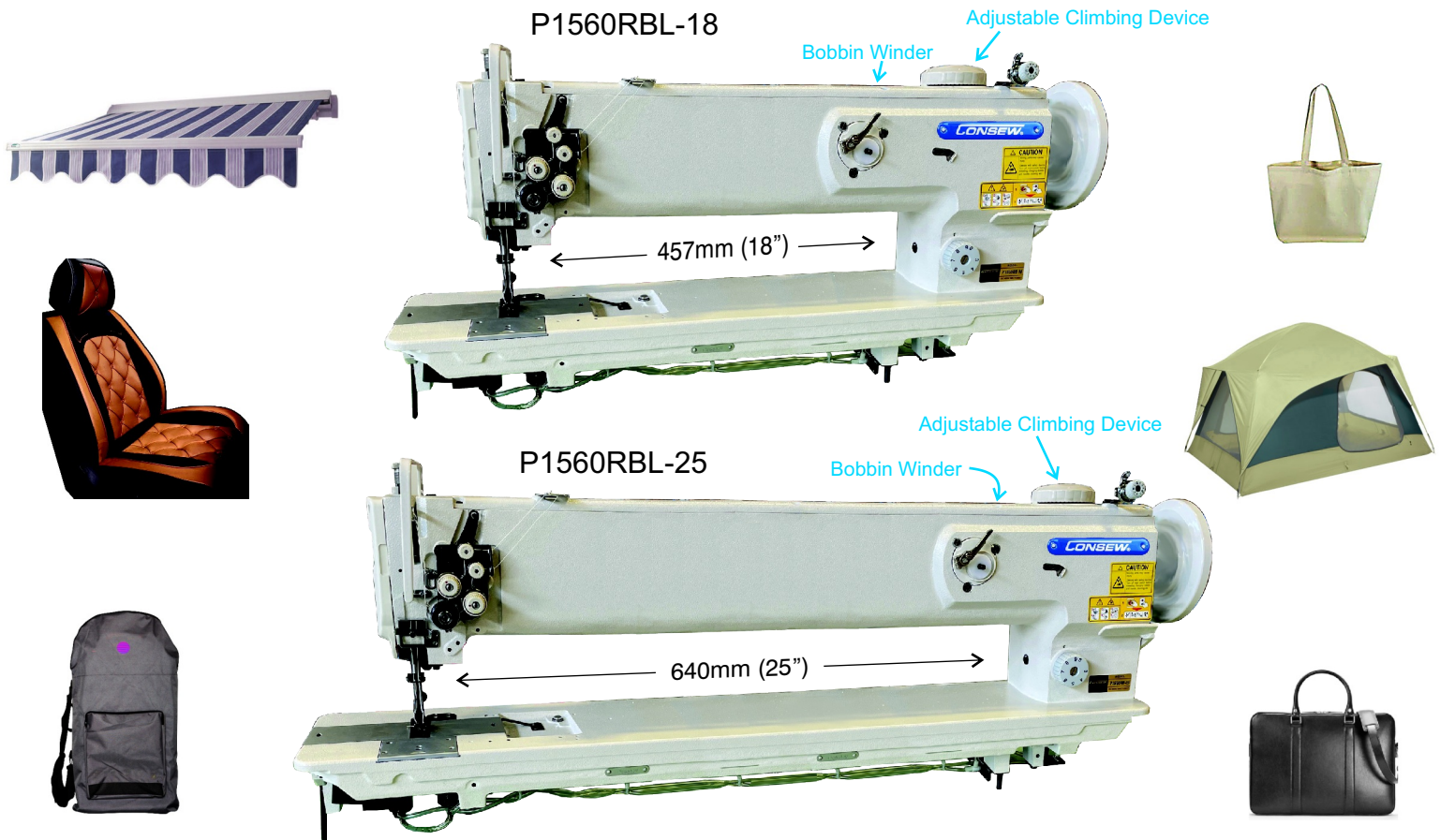

Don't forget to order the appropriate size Table/Stand/Motor for these standard powered machines. Complete Stand with K-Legs available separately.

Optional for the P1510RB, P1560RB & 1565RB series plain belt-driven machines.

Automatic Footlift Kit (complete) part# 285A1510

To be used with Consew motors CSM3002 and CSM4002

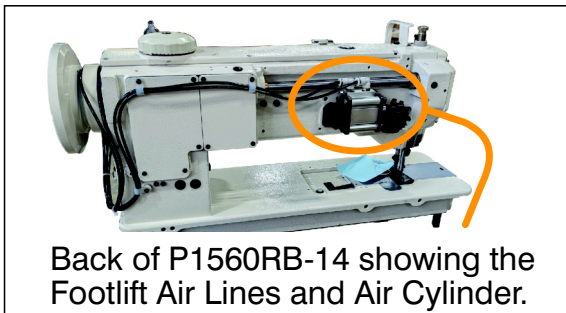

Back of P1560RB-14 showing the Footlift Air Lines and Air Cylinder.

Single solenoid setup includes...

FootLift Air Cylinder



285A1510



Single Electric Air Switch Solenoid Valve

Air Regulator with Dryer