



# **DIRECT DRIVE MOTOR and LED DISPLAY MANUAL**

**CM793-7DD  
CM794-7DD  
CM795-7DD**



*110-120 vac*

*Read these instructions carefully before operating machine.*

# 目 录

## Content

1、安全说明.....	2
General Safety Instructions	
2、产品介绍.....	2
Product Instructions	
3、安装调试（分直驱式和下挂式）.....	4
Installation and trial-run (Direct Drive & lower hanging)	
4、控制面板使用说明.....	5
Control Panel instruction	
5、一般故障处理.....	8
Common faults and treatment	
6、作业环境要求.....	9
Environmental Requirements	
7、保修服务.....	9
Warranty Service	
8、装箱单.....	10
Packing List	

## 一、安全说明:

### General Safety Instructions

1. 电机接通电源时请不要把脚放在脚踏板上  
Do not place your foot onto the pedal when connecting to the power source
2. 本产品需专业人员安装, 调试  
Installation and trial-run must be done by skilled person
3. 严禁在通电时打开控制箱与电机端盖  
Open control box or motor cover under electrical power is not permitted
4. 必须保证系统接地可靠  
Make sure the earthing system is working well
5. 以下操作请务必断电  
When doing the following the machine has to be disconnected from the power supply
  - A. 换针, 穿线或更换底线时  
When threading machine, replacing needle, bottom thread
  - B. 安装, 拆卸或修理时  
When install, dismantle and repair
  - C. 翻抬缝纫机时  
When turn over the sewing machine

## 二、产品介绍: Product Instruction

本产品由本公司自主研发, 产品个性鲜明, 真正体现出了机电一体化的概念, 更是节能, 高效, 环保, 优美集结于一身。可广泛适用于多种缝纫设备。

We design and manufacture the servomotor for the purpose of Mechanotronics. This motor features in energy-saving, high production efficiency, environmental and compact. Could be used for different industrial sewing machines.

### 1. 组成部分: Construction

控制系统由控制器和电机两部分:  
The servomotor is composed of control system and motor

- A. 控制器:** 控制箱和脚踏调速器。  
A. Control system includes control box and pedal speeder

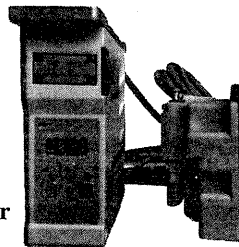

本控制系统体现出了超前的设计理念，系统操作简单易上手，整个控制系统性能优越。具有起步快，停车快、准等优点。而且电路模块保护功能完善：有欠压，过流，过热等一系列保护功能。脚踏调速器可实现无级调速。

This control system features is easy to use and features in excellent performance, including quick start, quick stop (sewing machine), accurate needle position. Furthermore, the modular circuit has Self-Protection System when against lower voltage, over current, over heat etc. Speed stepless is realized by the pedal speeder.

### **B.电机：motor**

电机转子属于稀土永磁钢，具备功率大，节能环保等各大优点。电机内设霍尔传感器，使电机具有准确的上下定位，使电机体积更小更美观。

Rotor is made of Rare earth permanent magnet, guarantee high power and environmental. Exactly needle UP/DOWN position due to its built-in Hall type sensor. Compact design.

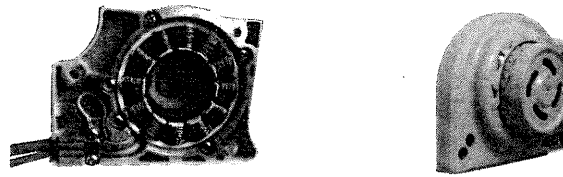

### **C.部份产品组装效果图：Partial demonstration**

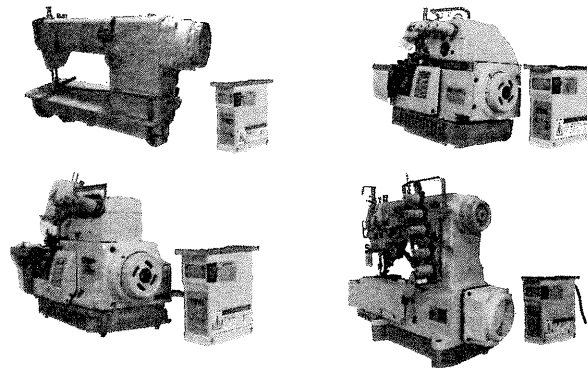

## 2、性能参数指标 Specifications

电源供电电压 Voltage	110V 两相 2 phase
频率 Frequency	50~60HZ
电机转速 Speed	200-6000RPM
电机扭矩 Motor torque	≤ 2N-M

## 三、安装调试：(直驱式电机安装方法)

### Installation and trial-run (Direct Drive type)

#### 1、控制箱脚踏板安装如下图

#### Install control box and pedal as below figure

将控制箱和脚踏板用螺钉依次安装在缝纫机台板指定的位置。

Using screws, mount the Control Box and Pedal onto sewing table properly.

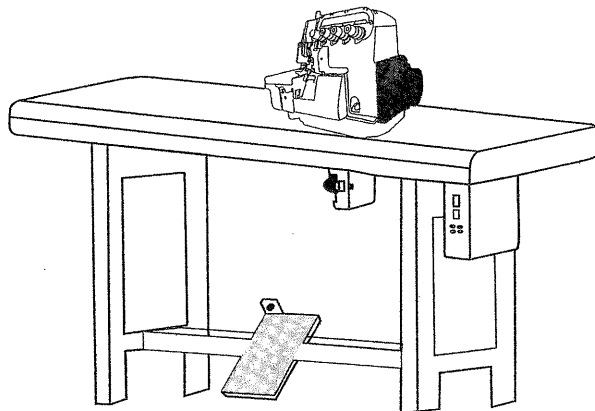

#### 2、直驱电机安装示意图如下

#### Install the direct drive motor as below figure

按1-8编号依次装入。注意：装好后用手转动主轴电机转子与定子无卡扎现象。

Mount below parts in turn. CHECK: turn the main shaft of motor by hand, no friction between stator and rotor

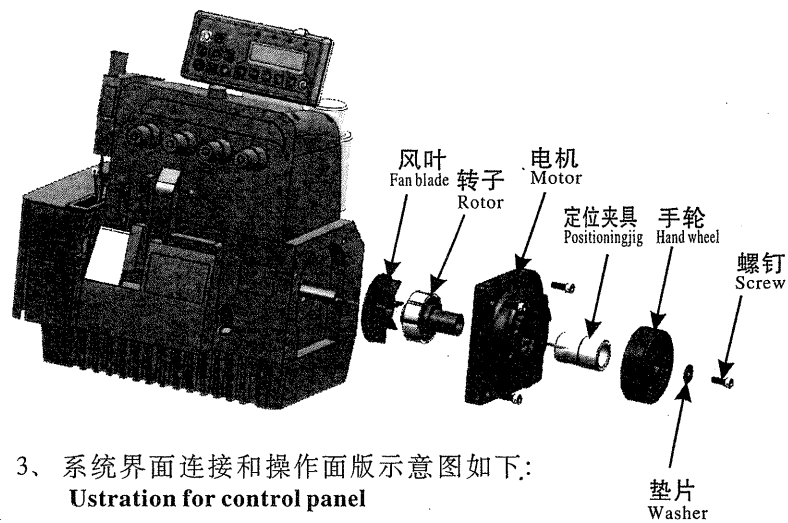

3、系统界面连接和操作面板示意图如下:

Ustration for control panel

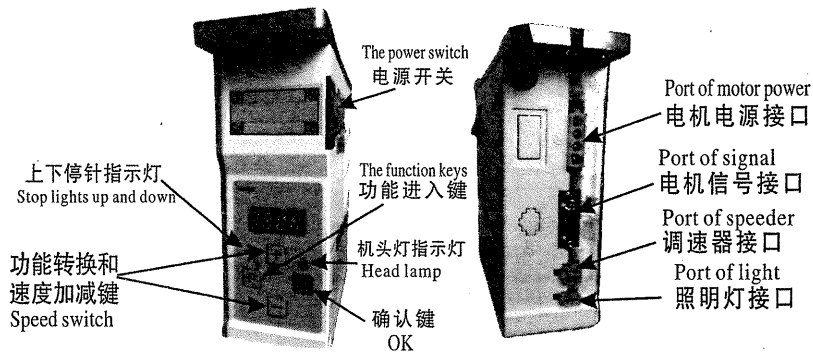

#### 四、控制面板使用说明: Installation for Control Panel

1.各按键的用途: Each key purpose:

(1) "P" 键 (1) "P" key

此键有两大用法: 第一个用处是直接按 "P" 键转换到上针孔灯亮为上停针, 下针孔灯亮 为下停针, 两个灯孔都不亮为不停针;  
This key has two uses : The first use is to direct press "P" key to switch up or down needle position, if up pinhole lamp lights means up needle position, if down pinhole lamp lights means down needle position, if two lamps off means no needle position.

第二个用处是: 功能进入键下面第2点有介绍.

The second use is: Function Enter button, below point 2 are described below.

(2) "S" 键 (2) "S" key

此键也有两大用法:

第一个用处是直接按 "S" 键转换到 "S" 键上的小灯亮为打  
开机头灯, 灭为关掉机头灯.

第二个用处是功能参数 (确认) 键下面第2点有介绍.

This button also has two uses: The first use is to simply press "S" key to  
off or on lamp on the head.

The second use is to function parameters (confirm) key, point  
2 are described below.

(3) "+" "-" 键 (3) "+" "-" key

此两个键是转速调整用。These two keys are used to adjust speed.

## 2. 进入参数的操作方法:

例: 怎样把电机的顺时针转调到逆时针转:

第一步: 先打开电源;

第二步: 先按 "P" 键不放, 再用另一只手按 "+" 号键, 此时  
画面会显示P-00

第三步: 此时按 "+" 号键, 画面会显示P-02, (P-02)就是电机  
正反转参数 (常用参数表上有)。

第四步: 此时按 "P" 键画面会显示 "1"

第五步: 此时按 "-" 号键把 "1" 调到 "0"

( "1" 为顺时针转, "0" 为逆时针转, 常用参数表上有)。

第六步: 按 "S" 键确定参数调整完毕并退出参数。

## (2) To enter the parameter method of operation:

Example: How to change the motor from clockwise to Counterclockwise

The first step: Open the power;

Step two: Press the "P" key, no leave, and use the other hand press the  
"+" key, the screen will display the P-00

The third step: press "+" key, the screen will display P-02, (P-02) is  
a motor clockwise or Counterclockwise parameters (common parameter  
list has).

Step Four: Now press "P" key (enter into parameter) screen will display "1"

Fifth step: press "-" key, change "1" to "0"

("1" clockwise "0" for the counter-clockwise, common parameters list has).

Step Six: Press the "S" key to determine the parameters, save and exit the  
parameter.

## 3. 恢复出厂设置:

恢复出厂设置方法: 先按 "P" 键不放, 再用另一只手按 "+"  
号键, 此时画面会显示P-00, 再长按 "S" 键约3秒即可, (恢复  
出厂设置值在常用参数表里)。

## 3. Restore factory settings:

Restore factory settings: Press the "P" key, no leave, and use the other  
hand press the "+" key, the screen will display the P-00, then press "S" key  
3 seconds, it will Restore factory settings.

4. 电机常用参数设置: Commonly used parameter setting

序号 The serial number	参数编号 Parameters of the code	参数名称 The parameter name	参数范围 Adjusting range		出厂设置 The factory reset Settings	备注 Other
1	P-01	最大速度锁定 Maximum speed lock	200-6500RPM		4500转	
2	P-02	电机方向 Direction of rotation	0是逆转 0 is reverse turn needle	1是顺针转 1 is a clockwise turn	1	老款平缝电机调到2或3
3	P-03	下停角度 The needle Angle	6-18度		12度	
4	P-04	起缝速度 Start sewing speed	200-800转		250转	
5	P-05	加速快慢 Speed up and slow	2000-4000转		3500转	
6	P-06	定针缝 Set the seam	0-999针		0	
7	P-07	空				
8	P-08	空				
9	P-09	空				
10	P-10	自动间隙运行 (跑合) Automatic clearance run (run)	把0改成1再按S键 Then press the S key change 0 to 1		0	关掉电源停止跑合 Turn off the electricity stopped running
11	P-11	抬压脚起时间 Presser foot ascend starting time	0-2000ms		0	
12	P-12	抬压脚保护时间 Ascension presser foot protection time	1-120 s		4s	
13	P-13	老款平车电机选择 Old motor selection	1是老款平缝机电机 Motor option 1 is the old one		0	0是普通机 0 is ordinary sewing machine
14	P-14	最大电流限制 Maximum current limiting	50-1000		280	
15	P-15	是否检测上针位 The location of the needle	1:检测针位, 0:不检测 1: detecting needle 0: no detection		1	



## 五、一般故障处理: Common faults and treatments

序号 The serial number	错误码 Error code	错误内容 Error content	错误问题的多种可能 Several possible error problem
1	Er01:	找不到停针位	1.手轮靠的不够近间隙在2mm内, 2.九针插头接触不良 3.电机霍儿坏,要更换电机, 4.手轮上的磁铁掉落. 1.The handwheel is not close, clearance within 2 mm. 2. Nine plug contact undesirable 3. Motor HuoEr bad, to replace the motor, 4. The handwheel magnet in the loss.
2	Er02:	开机没有检测到调速器 Not detected boot speed regulator	1.调速器插头没有插, 2.调速器线断了 1.Speed control device without plug, 2. Speed wire is broken
3	Er03:	电机霍儿或相位线错误 Motor HuoEr or phase error	1.九针插头接触不良, 2.电机没有按装好 3.霍儿坏 1. Nine hole plug contact undesirable, 2. The motor doesn't pack good, 3. HuoEr bad
4	Er04:	堵转保护 Locked-rotor protection	1.电机过载, 2.电机与电控相连接的四心线接触不好. 1. The motor overload, 2. The motor and the controller connected four hole line contact is not good
5	Er05:	硬件过流保护; Hardware over-current protection;	1.电机过载, 2.信号线接触不好或断了, 1. Motor overload, 2. Line contact is bad or broken,
6	Er07:	串口通信超时错误 serial port communication timeout error	显示屏至主板信号线不良或主板坏, Display to the system board signal bad or bad,

## 六、作业环境要求: Environmental Requirements

1. 请不要在过潮湿环境中作业  
Please do not work at damp place
2. 用户供电应保持稳定 110V  
The voltage requires being stable (110V)
3. 用户使用前必须接地，确保人身安全  
Must be adequately grounded for safety
4. 不要在过热地方作业  
Do not work at high temperature
5. 控制系统与电机不要在强磁高辐射环境中作业，  
以免干扰而使系统错误  
Do not run motor and control system near to ferromagnetic or  
high-radiance area

## 七、保修服务: Warranty Service

1. 本产品自购买起免费保修1年，终身维护。保修期内  
除人为损坏以外出现任何质量问题可免费维修。  
  
Our products come with 1 year of quality guarantee, from the ship day.  
Within guarantee period, service is free of charge, unless man-made  
damage or misuse.
2. 在保修期内，以下情况出现损坏本公司不给予保修  
服务。  
During the guarantee period, our free service does not cover below:
  - A. 未经本公司同意自行拆卸，修理，改装造成的故  
障或损坏。  
Dismantle the motor unit without permission, and cause damage.
3. 但凡出现无法解决的问题可以联系本公司。  
Please contact us whenever have problem.

## 八、装箱单：Packing List

电机定子	Stator	1
电机转子	Rotor	1
控制箱	Control Box	1
手轮	Hand wheel	1
脚踏板连接杆	Pipe link	1
内六角螺丝	Hexagon screw	6
定位护套	Locator bush	1
风叶	Fan blade	1
脚踏板	Pedal	1
自攻螺丝	Self tapping screw	6
说明书	Manual	1
合格证	Quality Certificate	1