

Since 1898
CONSEW®

Model 7360R-7DD-2



OPERATION AND PARTS MANUAL

IMPORTANT SAFETY INSTRUCTIONS

To get the most out of the many functions of this machine and operate it in safety, it is necessary to use this machine correctly. Please read this instruction Manual carefully before use. We hope you will enjoy the use of your machine for a long time. Please remember to keep this manual in a safe place.

1. Observe the basic safety measures, including, but not limited to the following ones, whenever you use the machine.
2. Read all the instructions, including, but not limited to this Instruction Manual before you use the machine. In addition, keep this Instruction Manual so that you may read it at anytime when necessary.
3. Use the machine after it has been ascertained that it conforms with safety rules/standards valid in your Country.
4. All safety devices must be in position when the machine is ready for work or in operation. The operation without the specified safety devices is not allowed.
5. This machine shall be operated by appropriately-trained operators.
6. For your personal protection, we recommend that you wear safety glasses.
7. For the following, turn off the power switch or disconnect the power plug of the machine from the receptacle.
 - 7-1 For threading needle(s), looper, spreader etc. And replacing bobbin.
 - 7-2 For replacing part(s) of needle, presser foot, throat plate, looper, spreader, feed dog, needle guard, folder, cloth guide etc.
 - 7-3 For repair work.
 - 7-4 When leaving the working place or when the working place is unattended.
8. If you should allow oil, grease, etc. used with the machine and devices to come in contact with your eyes or skin or swallow any of such liquid by mistake, immediately wash the contacted areas and consult a medical doctor.

9. Tampering with the live parts and devices, regardless of whether the machine is powered, is prohibited.
10. Repair, remodeling and adjustment works must only be done by appropriately trained technicians or specially skilled personnel. Only spare parts designated by can be used for repairs.
11. General maintenance and inspection works have to be done by appropriately trained personnel.
12. Repair and maintenance works of electrical components shall be conducted by qualified electric technicians or under the audit and guidance of specially skilled personnel. Whenever you find a failure of any of electrical components, immediately stop the machine.
13. Before making repair and maintenance works on the machine equipped with pneumatic parts such as an air cylinder, the air compressor has to be detached from the machine and the compressed air supply has to be cut off. Existing residual air pressure after disconnecting the air compressor from the machine has to be expelled. Exceptions to this are only adjustments and performance checks done by appropriately trained technicians or specially skilled personnel.
14. Periodically clean the machine throughout the period of use.

15. Grounding the machine is always necessary for the normal operation of the machine. The machine has to be operated in an environment that is free from strong noise sources such as high-frequency welder.
16. An appropriate power plug has to be attached to the machine by electric technicians. Power plug has to be connected to a grounded receptacle.

17. The machine is only allowed to be used for the purpose intended. Other used are not allowed.
18. Remodel or modify the machine in accordance with the safety rules/standards while taking all the effective safety measures. assumes no responsibility for damage by remodeling or modification of the machine.

19. Warning hints are marked with the two shown symbols.





Danger of injury to operator or service staff



Items requiring special attention

FOR SAFE OPERATION

 <p>DANGER</p>	<ol style="list-style-type: none">1. To avoid electrical shock hazards, neither open the cover of the electrical box for the motor nor touch the components mounted inside the electrical box.
 <p>CAUTION</p>	<ol style="list-style-type: none">1. To avoid personal injury, never operate the machine with any of the belt cover, Finger guard or safety devices removed.2. To prevent possible personal injuries caused by being caught in the machine, Keep your fingers, head and clothes away from the handwheel, V belt and the motor while the machine is operation. In addition, place nothing around them.3. To avoid personal injury, never put your hand under the needle when you turn "ON" the power switch or operate the machine.4. To avoid personal injury, never put your fingers into the thread take-up cover while the machine is in operation.5. The hook rotates at a high speed while the machine is in operation. To prevent possible injury to hands, be sure to keep your hands away from the vicinity of the hook during operation. In addition, be sure to turn OFF the power to the machine when replacing the bobbin.6. To avoid possible personal injuries, be careful not to allow your fingers in the machine when tilting/raising the machine head.
	<ol style="list-style-type: none">7. To avoid possible accidents because of abrupt start of the machine, turn OFF the power to the machine when tilting the machine head.8. If your machine is equipped with a servo-motor, the motor does not produce noise while the machine is at rest. To avoid possible accidents due to abrupt start of the machine, be sure to turn OFF the power to the machine.9. To avoid electrical shock hazards, never operate the sewing machine with the ground wire for the power supply removed.10. To prevent possible accidents because of electric shock or damaged electrical components(s), turn OFF the power switch in prior to the connection/disconnection of the power plug.

BEFORE OPERATION



CAUTION:

To avoid malfunction and damage of the machine, confirm the following.

- Before you put the machine into operation for the first time after the set up, clean it thoroughly.
- Remove all dust gathering during transportation and oil it well.
- Confirm that the power plug has been properly connected to the power supply.
- Never use the machine in the state where the voltage type is different from the designated one.
- The direction of rotation of the sewing machine is counterclockwise as observed from the handwheel side. Be careful not to rotate it in reverse direction.

Consew 7360R-7DD-2 Series

CONTENTS

◆ INSTRUCTION MANUAL

1. SPECIFICATIONS	1
2. INSTALLATION	1
3. ADJUSTING THE HEIGHT OF THE KNEE LIFTER	2
4. INSTALLING THE THREAD STAND	3
5. LUBRICATE	3
6. LUBRICATION	3
7. ADJUSTING THE AMOUNT OF OIL(OIL SPLASHES) IN THE HOOK	4
8. ATTACHING THE NEEDLE.....	5
9. SETTING THE BOBBIN INTO THE BOBBIN CASE	6
10. ADJUSTING THE STITCH LENGTH	6
11. PRESSER FOOT PRESSURE	6
12. HAND LIFTER	6
13. ADJUSTING THE HEIGHT OF THE PRESSER BAR	7
14. THREADING THE MACHINE HEAD	7
15. THREAD TENSION	8
16. THREAD TAKE-UP SPRING	8
17. ADJUSTING THE THREAD TAKE-UP STROKE	9
18. NEEDLE-TO-HOOK RELATIONSHIP	9
19. HEIGHT OF THE FEED DOG	10
20. TILT OF THE FEED DOG	10
21. ADJUSTING THE FEED TIMING	11
22. ADJUSTMENT OF THE PEDAL	12
23. PEDAL OPERATION	12
24. ONE-TOUCH TYPE REVERSE FEED STITCHING MECHANISM	13
25. ELECTRONIC CLIP WIRE	13
26. DISASSEMBLING OF OPERATION PANEL	14

◆ PARTS BOOK

1. MACHINE FRAME & MISCELLANEOUS COVER COMPONENTS	17-20
2. MAIN SHAFT & THREAD-UP LEVER COMPONENTS	21-22
3. NEEDLE BAR, UPRIGHT SHAFT & HOOK DRIVING SHAFT COMPONENTS	23-24
4. HAND LIFTER COMPONENTS	25-26
5. FEED MECHANISM COMPONENTS	27-30
6. THREAD TRIMMER COMPONENTS	31-32
7. AUTOMATIC REVERSE FEED COMPONENTS	33-34
8. ELECTRONIC CONDUCTOR HOLDER NEEDLE SELECTION BOX COMPONENTS	33-34
9. OIL LUBRICATION COMPONENTS	35-36
10. OIL RESERVOIR COMPONENTS	35-36
11. THREAD STAND COMPONENTS	37-38
12. ACCESSORIES	37-38

1. SPECIFICATIONS

Model	7360R-7DD-2	7360RH-7DD-2
Application	General fabrics, light-weight and medium-weight materials	Medium-weight materials Heavy-weight materials
Sewing speed	Max. 4,000 rpm	Max. 3.500 rpm
Max. Stitch length	4 mm	7 mm
Needle	DBX1 #9-#18 (#14)	DBX1 #20-#23 (#21)
Presser foot lift	10 mm (standard) 13 mm (Max.)	
Lubricating oil	White Oil 10	
Noise	Workplace-related noise at sewing speed $n = 4,500 \text{ min}^{-1} : L_{PA} \leq 83 \text{ dB(A)}$ Noise measurement according to DIN 45635-48-A-1.	

2. INSTALLATION

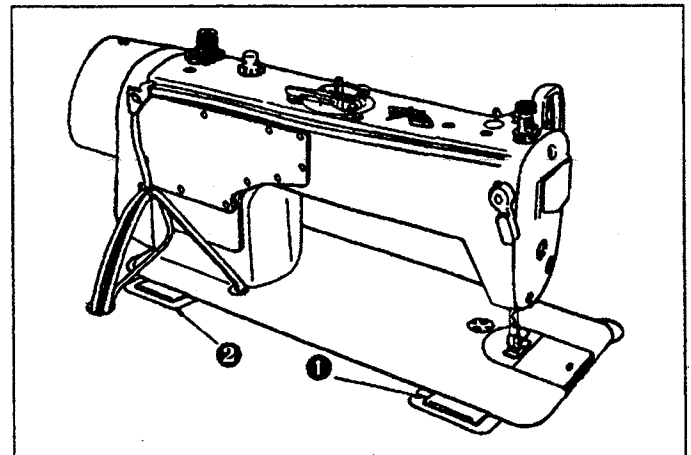
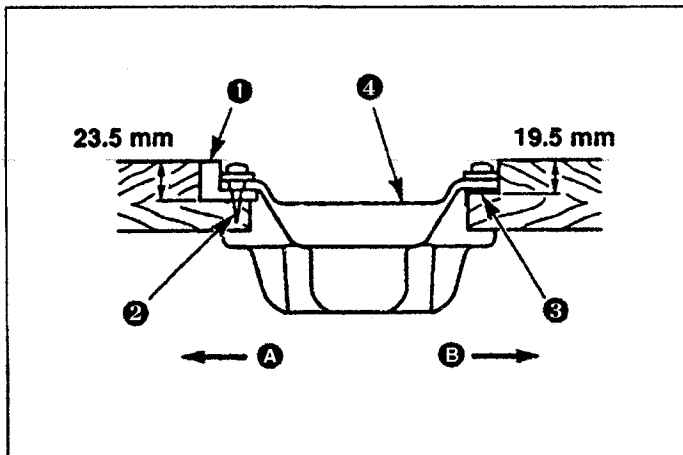
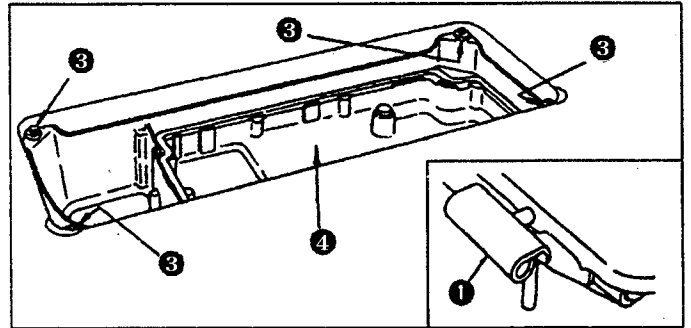
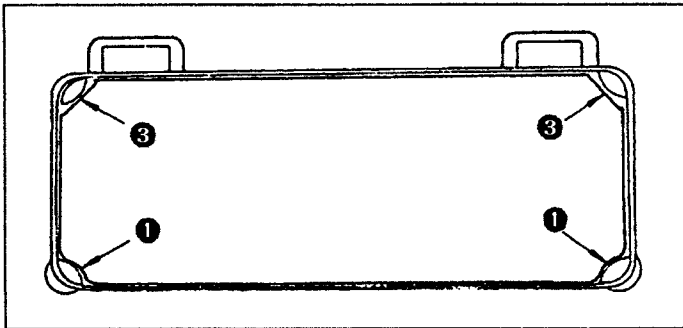

(1) Installing the under cover

- 1) The oil pan should rest on the four corners of the machine table groove.
- 2) Fix two rubber seats ① on side A (operator's side) using nails ② as illustrated above. Fix two cushion seats ③ on side B (hinged side) using a rubber-based adhesive. Then place oil pan ④ on the fixed seats.
- 3) Fit hinge ① into the opening in the machine bed, and fit the machine head to table rubber hinge ② before placing the machine head on cushions ③ on the four corners.

3. 膝动提升高度的调整 / ADJUSTING THE HEIGHT OF THE KNEE LIFTER

注意

为了防止意外的起动造成的事故，请关掉电源后进行。



WARNING:

Turn OFF the power before starting the work so as to prevent accidents caused by abrupt start of the sewing machine.

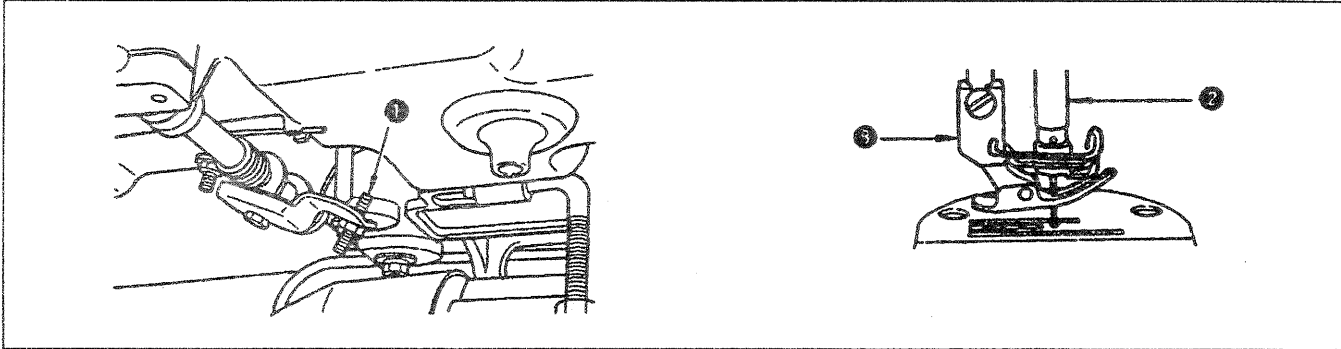

- 1) 膝动提升的压脚标准高度为10mm。
- 2) 调节膝动提升调节螺丝 ① 可以把压脚高度最大调整到13mm。(A型时最大为9mm。)
- 3) 压脚提升到 10 mm 以上时，请注意针杆 ② 的前端下降到最底下时，不能碰到压脚 ③。

- 1) The standard height of the presser foot lifted using the knee lifter is 10 mm.
- 2) You can adjust the presser foot lift up to 13 mm using knee lifter adjust screw ①. (Max. 9 mm for A type)
- 3) When you have adjusted the presser foot lift to over 10 mm, be sure that the bottom end of needle bar ② in its lowest position does not hit presser foot ③.

4. 线架装置的安装 / INSTALLING THE THREAD STAND

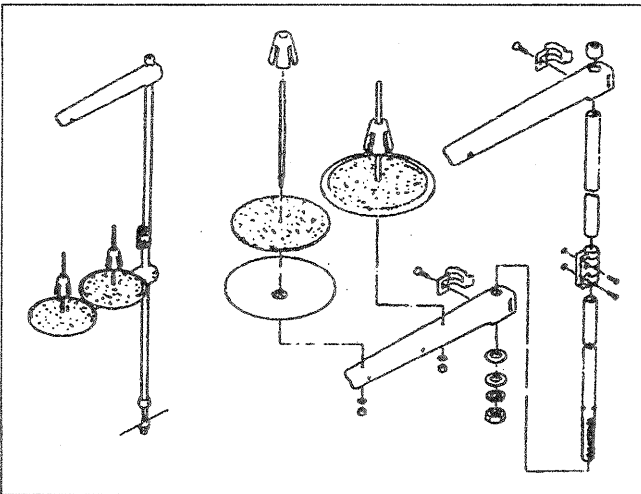

5. 加润滑脂 / LIPIN

注意

为了防止意外的起动造成的事故，请关掉电源后进行。



WARNING:

Turn OFF the power before starting the work so as to prevent accidents caused by abrupt start of the sewing machine.

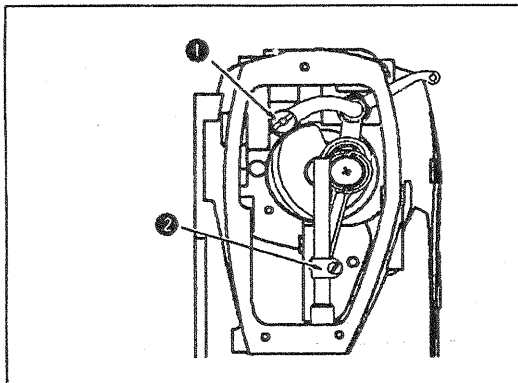

1) 请先卸下挑线连杆销①上的小螺钉后，将润滑脂注满挑线连杆销①的小孔内。

2) 请先拆下针杆连接柱组件后卸下针杆连接柱②上的小螺钉，将润滑脂注满针杆连接柱②的小孔内。

1) Full pore of the thread take-up crank shaft ① with lipin before disassembly small screw of the thread take-up crank shaft ①.

2) Disassembly small screw before Disassembly the needle rod holder ASM, then full pore of the needle bar connection ASM ② with lipin.

6. 加油 / LUBRICATION

注意

为了防止意外的起动造成的事故，请关掉电源后进行。



WARNING:

Turn OFF the power before starting the work so as to prevent accidents caused by abrupt start of the sewing machine.

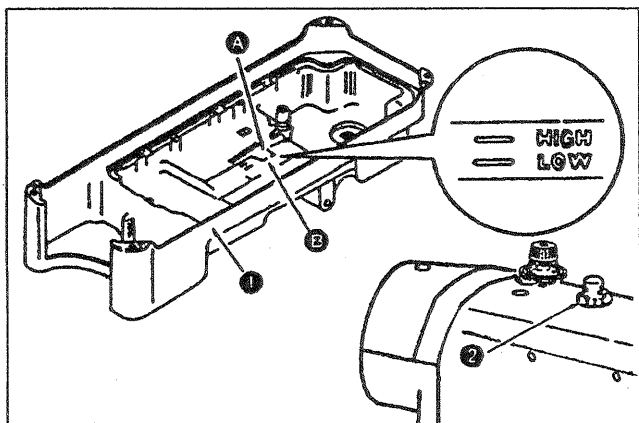

运转缝纫机前

1) 请把机油倒进油槽①里，一直加到 HIGH 标记 A 的位置。

2) 油槽的油面降到 LOW 标记 B 以下时，请再次补充机油。

3) 加油后运转缝纫机，如果润滑正常时，可以通过油窗②看到油的流动。

4) 油流动量的多少，与油量的多少无关。



注意 新缝纫机或较长时间没有使用的缝纫机在使用之前，应进行 10 分钟 3,000~3,500 rpm 的磨合运转。

Information on lubrication

- 1) Fill oil pan ① with Machine Oil up to HIGH mark A.
- 2) When the oil level lowers below LOW mark B, refill the oil pan with the specified oil.
- 3) When you operate the machine after lubrication, you will see splashing oil through oil sight window ② if the lubrication is adequate.
- 4) Note that the amount of the splashing oil is unrelated to the amount of the lubricating oil.



When you first operate your machine after setup or after an extended period of disuse, run your machine at 3,000 to 3,500 rpm. for about 10 minutes for the purpose of break-in.

7. 关于旋梭部油量（迹）调整方法 /

ADJUSTING THE AMOUNT OF OIL (OIL SPLASHES) IN THE HOOK

注意

旋梭是以高速运转。为了防止人身事故，调整油量时，请加以充分的注意。



WARNING:

Be extremely careful about the operation of the machine since the amount of oil has to be checked by turning the hook at a high speed.

① 油量（迹）确认专用纸

Amount of oil (oil splashes) confirmation paper

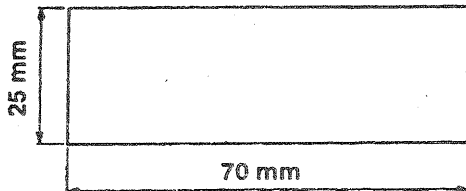

② 油量（迹）确认位置

Position to confirm the amount of oil (oil splashes)

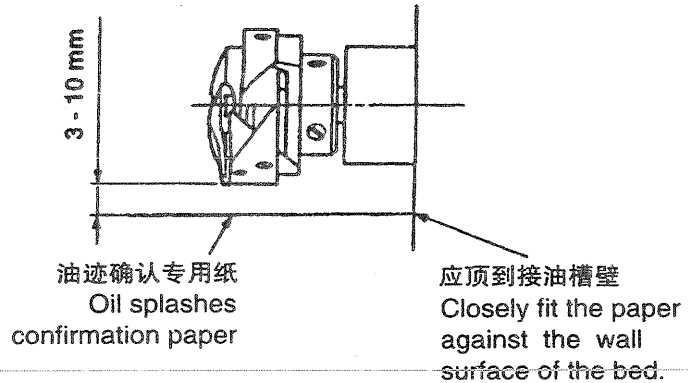

* 进行下列2)的作业时，请卸下滑板，同时要充分注意手指不要碰到旋梭。

- 1) 冷机头时，请进行3分钟左右的空运转。（适当的断续运转）
- 2) 油量（迹）确认专用纸在缝纫机转动后的状态下插进去。
- 3) 请确认油量的油面高度应在HIGH和LOW的范围之内。
- 4) 确认油量（迹）所需要的时间为5秒钟。（应看着表）

* When carrying out the procedure described below in 2, remove the slide plate and take extreme caution not to allow your fingers to come in contact with the hook.

- 1) If the machine has not been sufficiently warmed up for operation, make the machine run idle for approximately three minutes. (Moderate intermittent operation)
- 2) Place the amount of oil (oil splashes) confirmation paper under the hook while the sewing machine is in operation.
- 3) Confirm the height of the oil surface in the oil reservoir is within the range between "HIGH" and "LOW".
- 4) Confirmation of the amount of oil should be completed in five seconds. (Check the period of time with a watch.)

• 油量 (油迹) 适合标准 / Sample showing the appropriate amount of oil

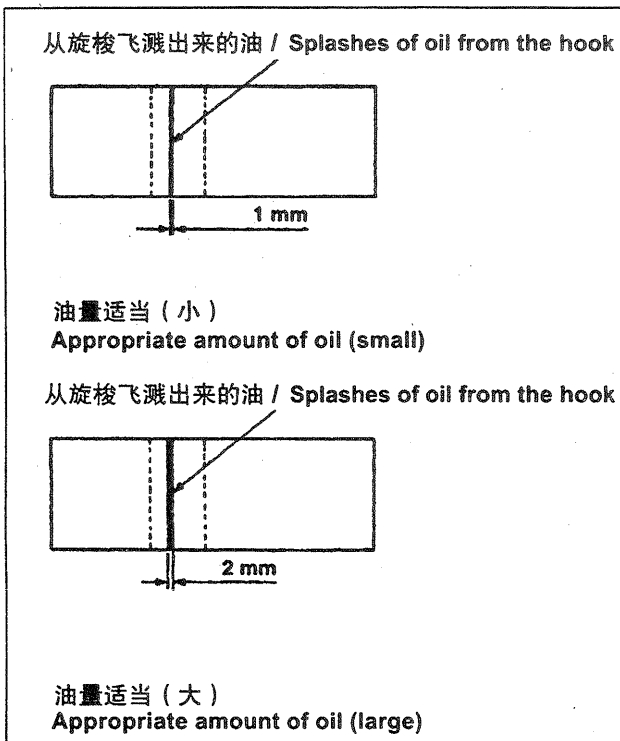

- 1) 左图标样根据缝制供需需要微调增减, 但注意不要过大增加或减少。
(油量过少时, 会烧坏旋梭 (发热)。油量过多时, 会脏污缝制品。)
- 2) 油量 (油迹) 应确认3次 (3张) 均无变化。

- 1) The amount of oil shown in the samples on the left should be finely adjusted in accordance with sewing processes. Be careful not to excessively increase/decrease the amount of oil in the hook. (If the amount of oil is too small, the hook will be seized (the hook will be hot). If the amount of oil is too much, the sewing product may be stained with oil.)
- 2) Adjust the amount of oil in the hook so that the oil amount (oil splashes) should not change while checking the oil amount three times (on the three sheets of paper)

• 旋梭油量 (迹) 调整 / Adjusting the amount of oil

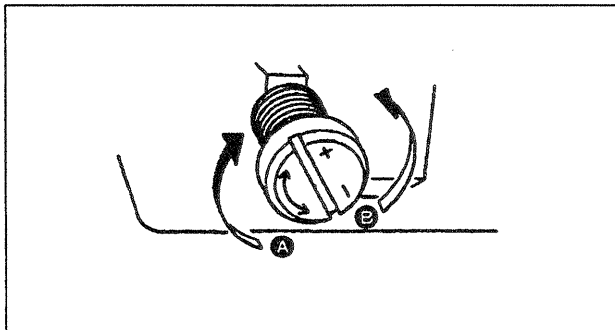

- 1) 把下轴前端金属部件上的油量调节螺丝向“+”的方向 (A方向) 转动, 油量 (迹) 变多, 向“-”的方向 (B方向) 转动, 油量 (迹) 变少。
- 2) 油量调节螺丝调整后的油迹, 应空运转 30 秒钟左右进行油量 (迹) 的确认。

- 1) Turning the oil amount adjustment screw attached on the hook driving shaft front bushing in the "+" direction (in direction A) will increase the amount of oil (oil spots) in the hook, or in the "-" direction (in direction B) will decrease it.
- 2) After the amount of oil in the hook has been properly adjusted with the oil amount adjustment screw, make the sewing machine run idle for approximately 30 seconds to check the amount of oil in the hook.

8. 机针的安装 / ATTACHING THE NEEDLE

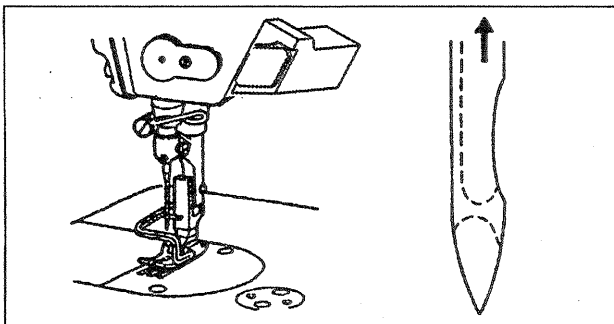
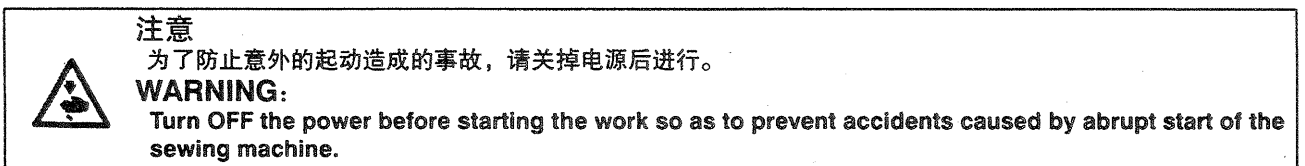

9. 梭心的安装方法 / SETTING THE BOBBIN INTO THE BOBBIN CASE

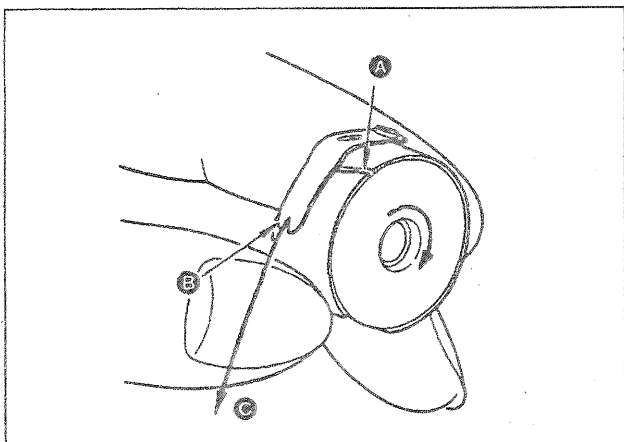

1) 把线穿过梭壳的穿线口A，然后把线往B方向拉，从线张力弹簧下面的穿线口B拉出来。

2) 拉底线C，确认梭心是否按箭头方向转动。

1) Pass the thread through thread slit A, and pull the thread in direction B.

By so doing, the thread will pass under the tension spring and come out from notch B.

2) Check that the bobbin rotates in the direction of the arrow when thread C is pulled.

10. 线迹长度的调节 / ADJUSTING THE STITCH LENGTH

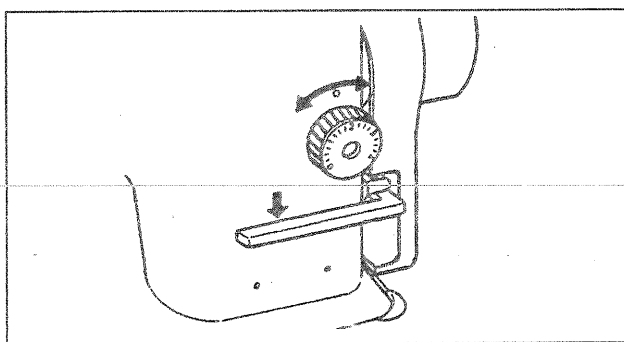

11. 压脚压力的调节 / PRESSER FOOT PRESSURE

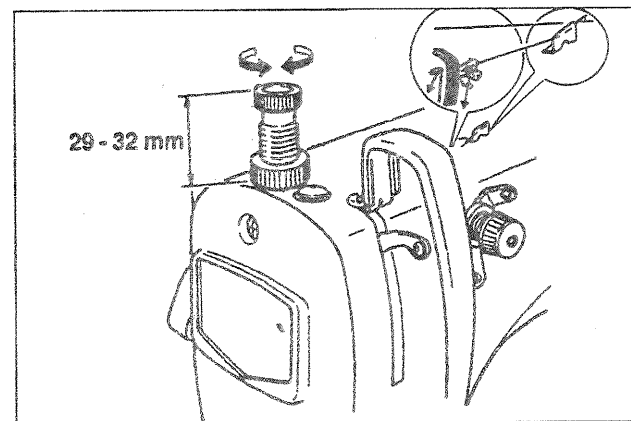

12. 关于压脚提升 / HAND LIFTER

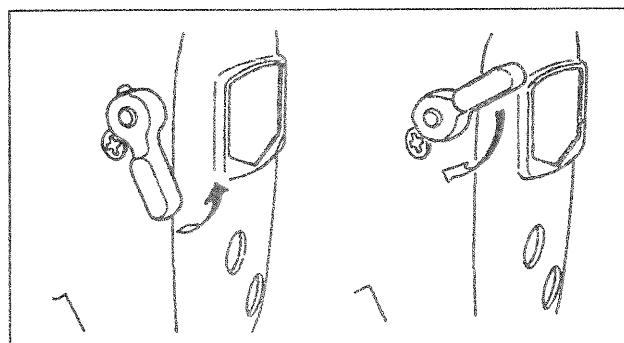

13. 压脚杆高度的调整 / ADJUSTING THE HEIGHT OF THE PRESSER BAR

注意

为了防止意外的起动造成的事故，请关掉电源后进行。



WARNING:

Turn OFF the power before starting the work so as to prevent accidents caused by abrupt start of the sewing machine.

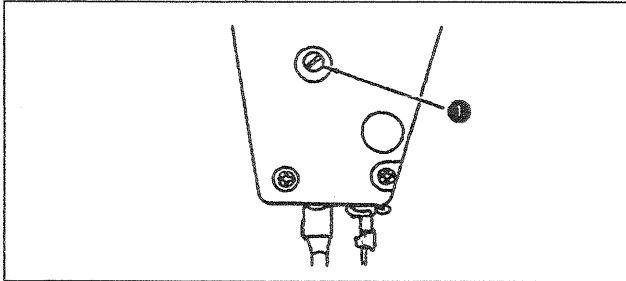

1) 变更压脚杆的高度或压脚的角度时，请拧松压脚杆套管固定螺丝①进行调整。

2) 调整后，拧紧固定螺丝①。

1) Loosen setscrew ①, and adjust the presser bar height or the angle of the presser foot.

2) After adjustment, securely tighten the setscrew ①.

14. 上线的穿线方法 / THREADING THE MACHINE HEAD

注意

为了防止意外的起动造成的事故，请关掉电源后进行。



WARNING:

Turn OFF the power before starting the work so as to prevent accidents caused by abrupt start of the sewing machine.

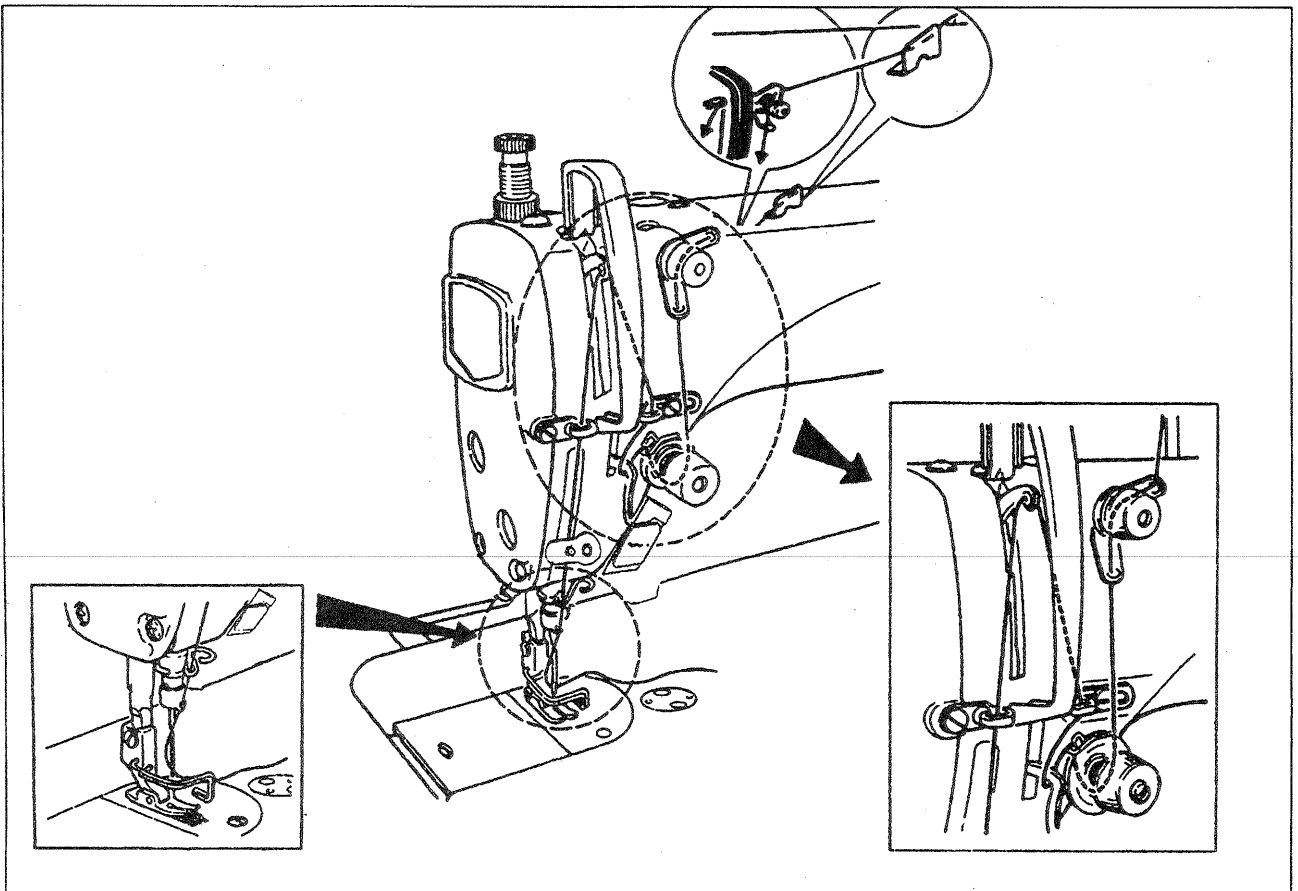

15. 线张力器 / THREAD TENSION

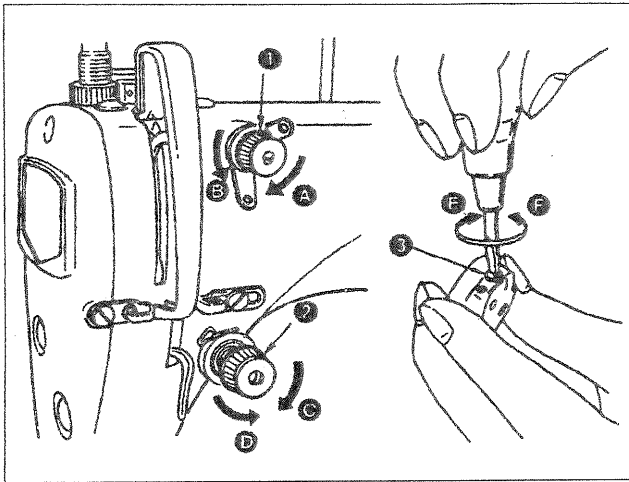

(1) 上线张力的调整

- 1) 向右 **A** 的方向转动第一线张力螺母 **①**，切线后残留在机针上的线长度变短。
- 2) 向左 **B** 的方向转动，则长度变长。
- 3) 向右 **C** 的方向转动第二线张力螺母 **②**，上线张力变强。
- 4) 向左 **D** 的方向转动，则上线张力变弱。

(2) 底线张力的调整

- 1) 向右 **E** 的方向转动线张力螺丝 **③**，底线张力变强。
- 2) 向左 **F** 的方向转动线张力螺丝，则底线张力变弱。

(1) Adjusting the needle thread tension

- 1) As you turn thread tension No.1 nut **①** clockwise (in direction **A**), the thread remaining on the needle after thread trimming will be shorter.
- 2) As you turn nut **①** counterclockwise (in direction **B**), the thread length will be longer.
- 3) As you turn thread tension No.2 nut **②** clockwise (in direction **C**), the needle thread tension will be increased.
- 4) As you turn nut **②** counterclockwise (in direction **D**), the needle thread tension will be decreased.

(2) Adjusting the bobbin thread tension

- 1) As you turn tension adjust screw **③** clockwise (in direction **E**), the bobbin thread tension will be increased.
- 2) As you turn screw **③** counterclockwise (in direction **F**), the bobbin thread tension will be decreased.

16. 挑线弹簧 / THREAD TAKE-UP SPRING

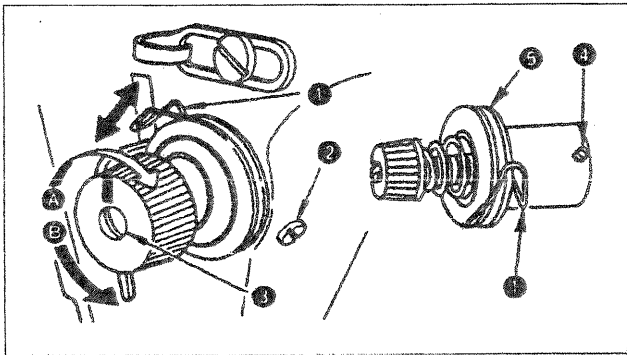

(1) 挑线弹簧 **①** 的行程量调整

- 1) 拧松线张力台的固定螺丝 **②**。
- 2) 向右 **A** 的方向转动线张力杆 **③**，则行程量变大。
- 3) 向左 **B** 为了防止布的跑偏，需要提早。

(2) 挑线弹簧 **①** 的压力调整

- 1) 拧松固定螺丝 **②**，卸下线张力杆 **⑤**。
- 2) 拧松线张力杆固定螺丝 **④** 进行调整。
- 3) 向右 **A** 的方向转动线张力杆 **③** 则压力变强。
- 4) 向左 **B** 的方向转动压力则压力变弱。

(1) Changing the stroke of thread take-up spring **①**

- 1) Loosen setscrew **②**.
- 2) As you turn tension post **③** clockwise (in direction **A**), the stroke of the thread take-up spring will be increased.
- 3) As you turn the knob counterclockwise (in direction **B**), the stroke will be decreased.

(2) Changing the pressure of thread take-up spring **①**

- 1) Loosen setscrew **②**, and remove thread tension (asm) **⑤**.
- 2) Loosen setscrew **④**.
- 3) As you turn tension post **③** clockwise (in direction **A**), the pressure will be increased.
- 4) As you turn the post **③** counterclockwise (in direction **B**), the pressure will be decreased.

17. 挑线杆挑线量的调整 / ADJUSTING THE THREAD TAKE-UP STROKE

注意

为了防止意外的启动造成的事故，请关掉电源后进行。



WARNING:

Turn OFF the power before starting the work so as to prevent accidents caused by abrupt start of the sewing machine.

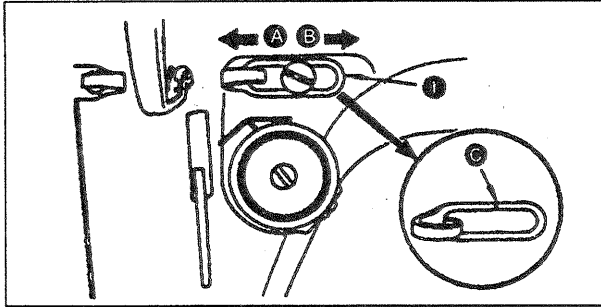

- 1) 缝制厚料时，向左(A)的方向移动线导向器①，则挑线量变多。
- 2) 缝制薄料时，向右(B)的方向移动线导向器①，则挑线量变少。
- 3) 线导向器①在刻线(C)对准螺丝的中心时是标准位置。

- 1) When sewing heavy-weight materials, move thread guide ① to the left (in direction A) to increase the length of thread pulled out by the thread take-up.
- 2) When sewing light-weight materials, move thread guide ① to the right (in direction B) to decrease the length of thread pulled out by the thread take-up.
- 3) Normally, thread guide ① is positioned in a way that marker line C is aligned with the center of the screw.

18. 机针与旋梭的关系 / NEEDLE-TO-HOOK RELATIONSHIP

注意

为了防止突然启动造成人身事故，请关掉电源，确认马达确实停止转动后再进行。



WARNING:

To avoid possible personal injury due to abrupt start of the machine, turn off the power to the machine and check to be sure that the motor has totally stopped rotating in prior.

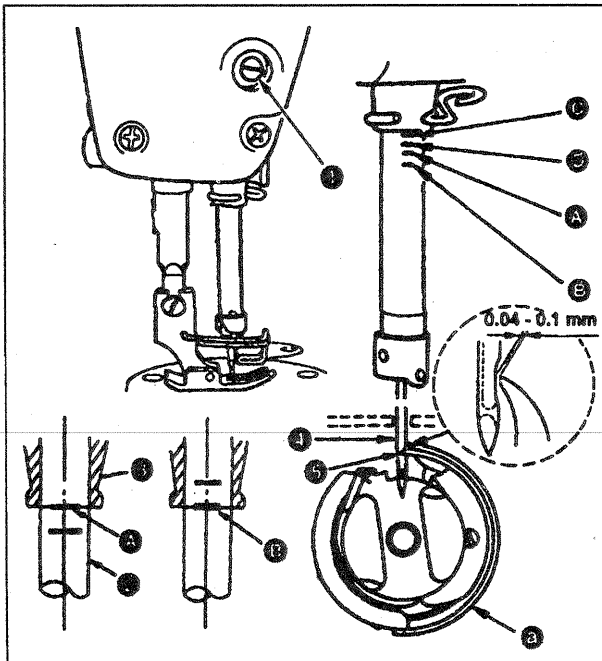

(1) 请按如下方法调整机针和旋梭。

- 1) 转动飞轮，让针杆降到最下点，然后拧松针杆套管固定螺丝①。
(决定针杆高度)
- 2) [DB针时]
把针杆②的刻线A对准针杆下套筒③的下端，然后拧紧针杆套管固定螺丝①。
[DA针时]
把针杆②的刻线C对准针杆下套筒③的下端，然后拧紧针杆套管固定螺丝①。
(决定旋梭a的安装位置)
- 3) [DB针时]
拧松3根旋梭固定螺丝，转动飞轮在针杆②上升的方向，把刻线B对准针杆下套筒③的下端。
[DA针时]
拧松3根旋梭固定螺丝，转动飞轮在针杆②上升的方向，把刻线D对准针杆下套筒③的下端。

- 4) 在此状态下，让旋梭尖⑤对准机针④的中心，把机针与旋梭的间隙调整为0.04~0.1mm(大致)，然后拧紧螺丝。



注 意

间隙过小的话，会损伤旋梭尖。间隙过大的话，会跳针。

(1) Adjust the timing between the needle and the hook as follows:

1) Turn the handwheel to bring the needle bar down to the lowest point of its stroke, and loosen setscrew ①.

(Adjusting the needle bar height)

2) (For a DB needle) Align marker line ① on needle bar ② with the bottom end of needle bar lower bushing ③, then tighten setscrew ①.

(For a DA needle) Align marker line ④ on needle bar ② with the bottom end of needle bar lower bushing ③, then tighten setscrew ①.

(Adjusting position of the hook ⑤)

3) (For a DB needle) Loosen the three hook setscrews, turn the handwheel and align marker line ⑥ on ascending needle bar with the bottom end of needle bar lower bushing ③.

(For a DA needle) Loosen the three hook setscrews, turn the handwheel and align marker line ⑦ on ascending needle bar with the bottom end of needle bar lower bushing ③.

4) After making the adjustments mentioned in the above steps, align hook blade point ⑧ with the center of needle ④. Provide a clearance of 0.04 mm to 0.1mm (reference value) between the needle and the hook, then securely tighten setscrews in the hook.



If the clearance between the blade point of hook and the needle is smaller than the specified value, the blade point of hook will be damaged. If the clearance is larger, stitch skipping will result.

19. 送布牙的高度 / HEIGHT OF THE FEED DOG

注意

为了防止意外的起动力造成的事故，请关掉电源后进行。

WARNING:

Turn OFF the power before starting the work so as to prevent accidents caused by abrupt start of the sewing machine.

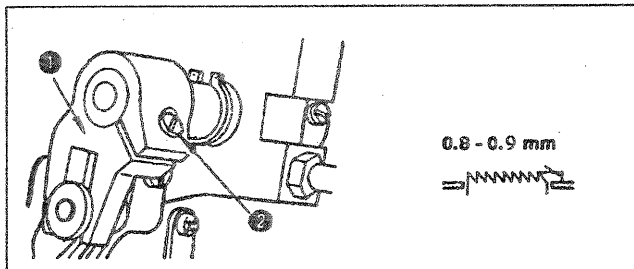

调节送布牙的高度时

① 拧松上下送布双叉 ① 的紧固螺丝 ②。

② 上下移动送布台进行调节。

③ 拧紧固定螺丝 ②。



注意 紧固压力过弱的话，抬牙叉部的动作则变得不灵活了。

To adjust the height of the feed dog:

① Loosen screw ② of crank ①.

② Move the feed bar up or down to make adjustment.

③ Securely tighten screw ②.



If the clamping pressure is insufficient, the motion of the forked portion becomes heavy.

20. 送布牙的倾斜 / TILT OF THE FEED DOG

注意

为了防止意外的起动力造成的事故，请关掉电源后进行。

WARNING:

Turn OFF the power before starting the work so as to prevent accidents caused by abrupt start of the sewing machine.

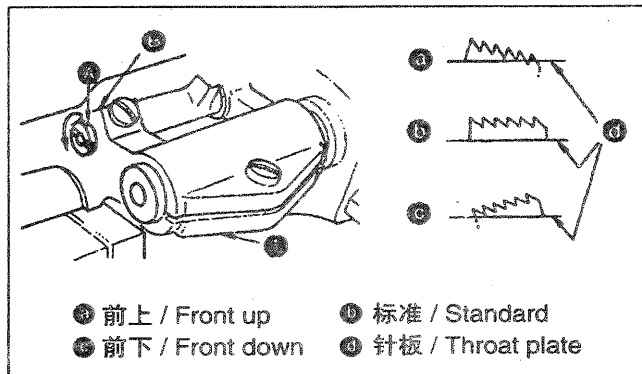

1) 标准倾斜（水平）度是送布台轴的刻点 ① 和送布台曲柄 ② 的 ③ 部一致时的位置。

（的标准倾斜是对 ④ 部呈90度水平送布面向轴侧的位置。）

2) 为了防止缝制皱摺，向前抬起送布牙时，请拧松固定螺丝，把螺丝刀插入送布台轴，然后沿箭头方向转90度。

3) 为了减少布的偏斜，向前下降送布牙时，请沿与箭头方向相反方向转90度。



调节了送布牙之后，送布齿的高度会有变化，请再次确认。

- 1) The standard tilt (horizontal) of the feed dog is obtained when marker dot **A** on the feed bar shaft is aligned with marker dot **B** on feed rocker **1**. (the marker dot **B** inclines forward the feed rocker shaft by 90°, as standard).
- 2) To tilt the feed dog with its front up in order to prevent puckering, loosen the setscrew, and turn the feed bar shaft 90° in the direction of the arrow, using a screwdriver.
- 3) To tilt the feed dog with its front down in order to prevent uneven material feed, turn the feed bar shaft 90° in the opposite direction from the arrow. (The standard tilt for.)



Whenever the feed dog tilt is adjusted, the feed dog height will be changed. So, it is necessary to check the height after tilt adjustment.

21. 送布相位的调节 / ADJUSTING THE FEED TIMING



注意

为了防止突然启动造成人身事故，请关掉电源，确认马达确实停止转动后再进行。

WARNING:

To avoid possible personal injury due to abrupt start of the machine, turn off the power to the machine and check to be sure that the motor has totally stopped rotating in prior.

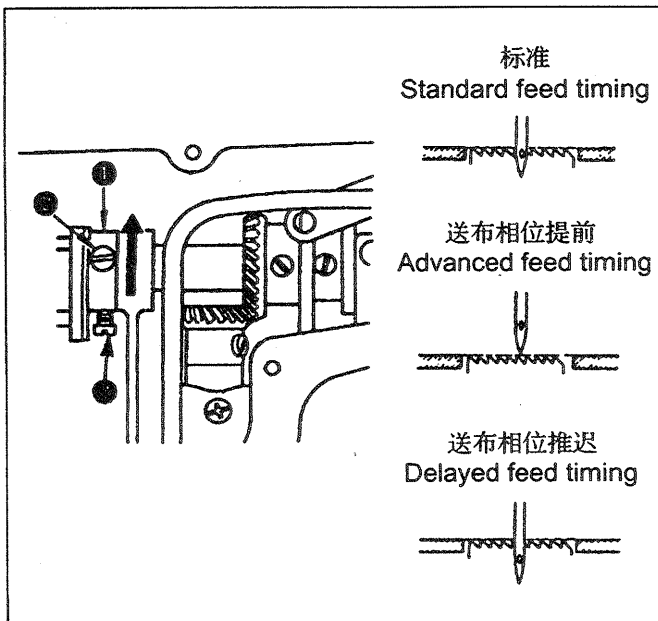

- 1) 拧松送布偏心凸轮**1**的固定螺丝**2**、**3**，朝箭头方向或反箭头方向移动送布偏心凸轮，然后拧紧固定螺丝。
- 2) 标准调节位置是送布牙从针板下落时，送布牙上面与针孔上端对准针板上面的位置。
- 3) 提早送布相位以防止布偏斜时，请向箭头方向移动送布偏心凸轮。
- 4) 为了良好的紧线而推迟相位时，请逆箭头方向移动偏心凸轮。



移动距离过大会发生断针故障。

- 1) Loosen screws **2** and **3** in feed eccentric cam **1**, move the feed eccentric cam in the direction of the arrow or opposite direction of the arrow, and firmly tighten the screws.
- 2) For the standard adjustment, adjust so that the top surface of feed dog and the top end of needle eyelet are flush with the top surface of throat plate when the feed dog descends below the throat plate.
- 3) To advance the feed timing in order to prevent uneven material feed, move the feed eccentric cam in the direction of the arrow.
- 4) To delay the feed timing in order to increase stitch tightness, move the feed eccentric cam in the opposite, direction from the arrow.



Be careful not to move the feed eccentric cam too far, or else needle breakage may result.

22. 踏板的调整 / ADJUSTMENT OF THE PEDAL

注意

为了防止意外的起动造成的事故，请关掉电源后进行。

WARNING:

Turn OFF the power before starting the work so as to prevent accidents caused by abrupt start of the sewing machine.

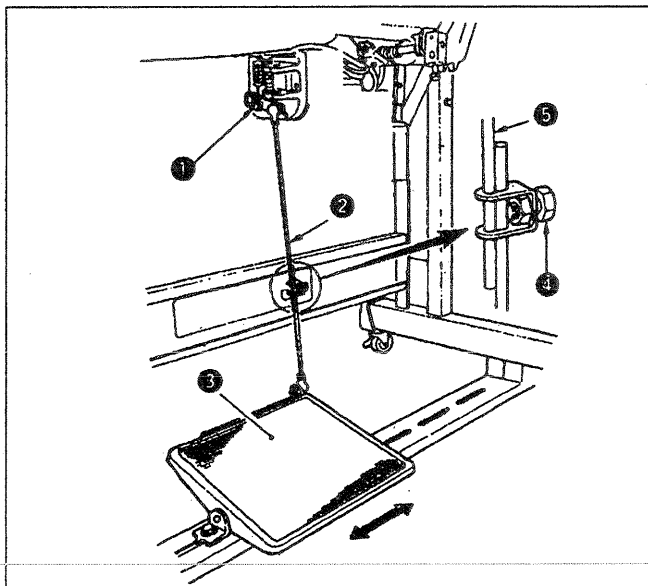

(1) 连接杆的安装

1) 向箭头方向移动踏板调节板 ③，让踏板拨杆 ① 和连接杆 ② 呈一直线。

(2) 踏板的角度

1) 调节连接杆的长度就可以自由地改变踏板的倾斜度。

2) 拧松调节螺丝 ④，拉出插入连接杆 ⑤ 进行调整。

(1) Installing the connecting rod

1) Move pedal ③ to the right or left as illustrated by the arrow so that motor control lever ① and connecting rod ② are straightened.

(2) Adjusting the pedal angle

1) The pedal tilt can be freely adjusted by changing the length of the connecting rod.

2) Loosen adjust screw ④, and adjust the length of connecting rod ⑤.

23. 踏板操作 / PEDAL OPERATION

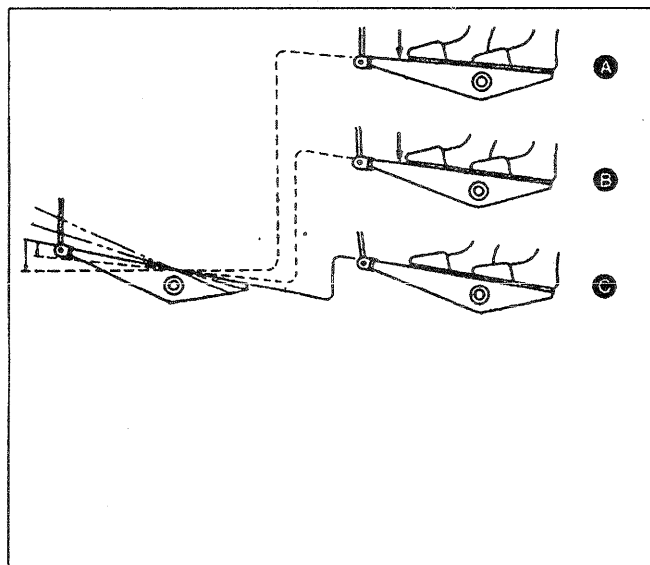

(1) 踏板按4个阶段进行操作。

1) 向前轻轻踩踏板为低速缝制 ②。

2) 再用力向前踩踏板则变为高速缝制 ①。

3) 把踏板返回到脚轻轻地放到踏板上的位置缝纫机停止 ③。（机针上停止或下停止位置）

(1) The pedal is operated in the following four steps:

1) The machine runs at low sewing speed when you lightly depress the front part of the pedal. ②

2) The machine runs at high sewing speed when you further depress the front part of the pedal. ①

3) The machine stops (with its needle up or down) when you reset the pedal to its original position. ③

24. 触键手动倒缝 /

ONE-TOUCH TYPE REVERSE FEED STITCHING MECHANISM

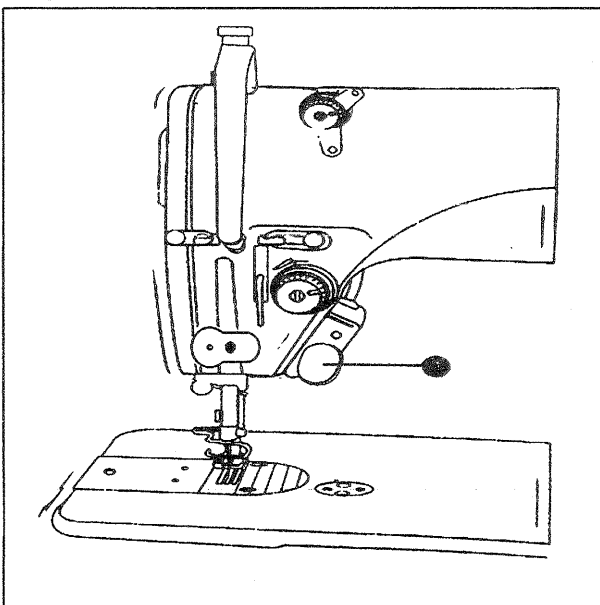

(1) How to operate

- 1) The moment switch lever ① is pressed, the machine performs reverse feed stitching.
- 2) The machine performs reverse feed stitching as long as the switch lever is held pressed.
- 3) The machine resumes normal feed stitching the moment the switch lever is released.



WARNING:

Turn OFF the power before starting the work so as to prevent accidents caused by abrupt start of the sewing machine.

(2) Height of the switch lever

- 1) Adjust the height of switch lever ① so that it can be easily operated.

(1) 使用方法

- 1) 按开关拨杆 ①，缝纫机立即变为倒送，进行倒缝。
- 2) 按下拨杆的时间，可以进行倒缝。
- 3) 放开拨杆，则立即返回到正缝。



注意

为了防止意外的起动的事故，请关掉电源后进行。

(2) 开关拨杆的高度

- 1) 请把开关拨杆 ① 的高度调整到使用方便的位置。

25. 电子夹线 / ELECTRONIC CLIP WIRE



注意

为了防止意外的起动的事故，请关掉电源后进行。

WARNING:

Turn OFF the power before starting the work so as to prevent accidents caused by abrupt start of the sewing machine.

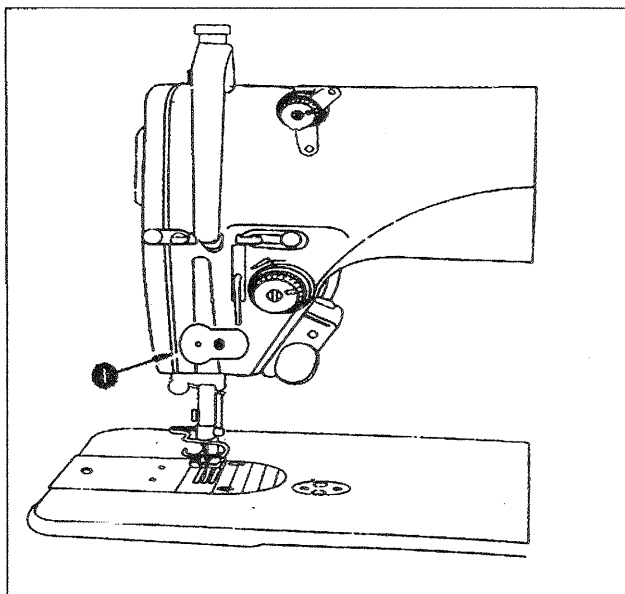

(1) 电子夹线器。 ①

- 1) Electronic clip wire ①

- 2) 电子夹器 ② 打开为 1mm。

- 2) Electronic clip wire ② open as 1mm.

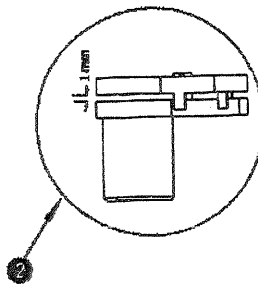

26. 操作面板, 拆装顺序 DISASSEMBLING OF OPERATION PANEL

注意

为了防止意外的启动造成的事故, 请关掉电源后进行。



WARNING:

Turn OFF the power before starting the work so as to prevent accidents caused by abrupt start of the sewing machine.

拆步骤 Disassembling steps

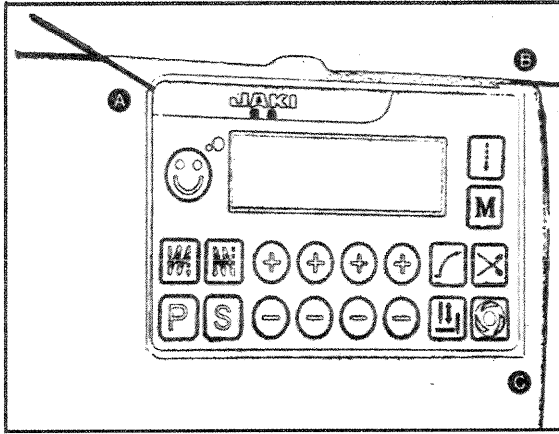

1. 用机针撬开A. B. C. 位置 .

1. Use needle to open a. b. c.

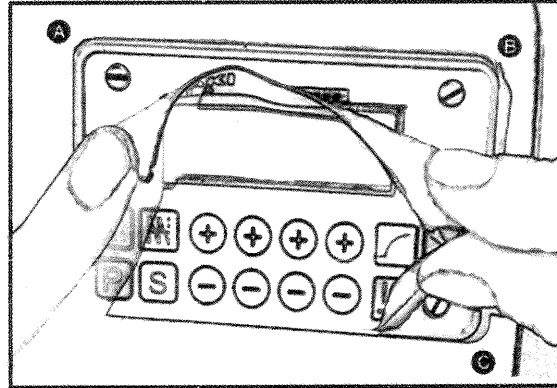

2. 轻轻揭开操作面板A. B. C. 位置, 露出螺钉的位置.

2. operation panel a. b. c. place To see the screw

3. 拧下螺钉

3. Twist down the screw

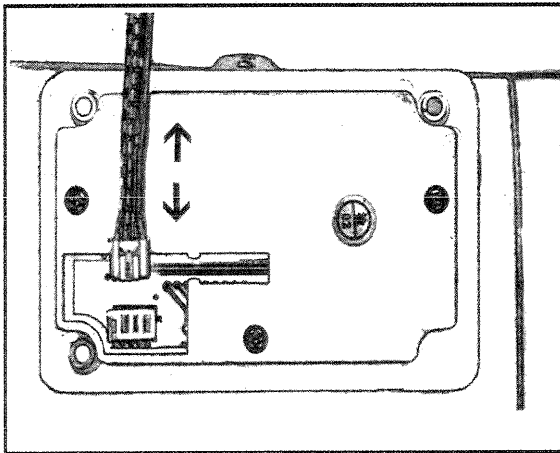

4. 取下操作面板, 拨出连接插头

4. Remove the operation panel, Set aside

装步骤 assembling steps

按先拆后装的顺序装上操作面板。

Install the operation panel according to the first of disassembly after assembly.



7360R-7DD-2

**PARTS
SECTION**

1.机壳·外装部件

MACHINE FRAME&MISCELLANEOUS COVER COMPONENTS

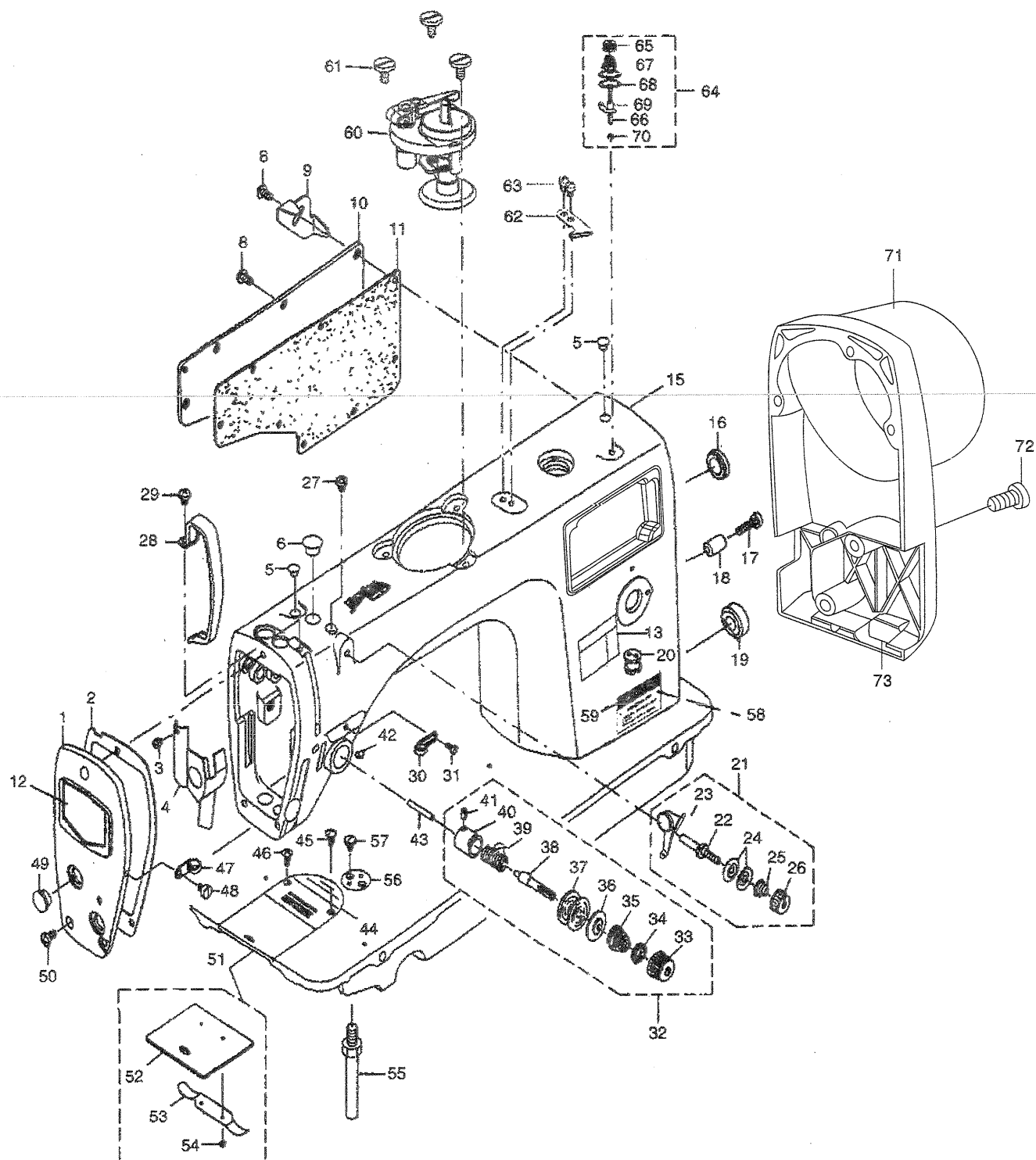

1.机壳·外装部件

序号 Ref. NO.	件号 Part NO.	名称	Description	数量 Qty	备注 Note
1	102.01-01-P	面板	Face plate	1	
2	102.01-02-P	面板垫	Face plate agsket	1	
3	02-608440421-1	防油板螺钉	Screw 1/8x44 L=4	1	
4	102.01-04	面板防油板部件	Arm oil shifld asm.	1	
5	102.01-05	挑线连杆销螺孔塞	Rubber plug	3	
6	102.01-06	针杆曲柄螺孔塞	Rubber plug	1	
7	102.01-07	三眼过线板	Three eye line board	1	
8	02-412280923-1	后窗板螺钉	Screw 3/16x28 L=9	7	
9	102.01-09	导线夹板	Cord holder	1	
10	102.01-10	后窗板	Side plate	1	
11	102.01-11	后窗板垫	Gasket	1	
12	102.01-12	面板装饰片	Face plate	1	
13	102.01-13	安全指示牌	Safety label	1	
14	02-412281423-1	后窗板螺钉	Screw 3/16x28 L=14	3	
15	102.01-15-P	机壳	Machine cover	1	
16	102.01-16	送料调节器孔塞	Rubber plug	1	
17	02-512281821-1	倒缝限套紧固螺钉	Screw 3/16x28 L=18	1	
18	102.01-18	倒缝限位套	Reverse feed lever stopper	1	
19	102.01-19	下轴盲孔塞	Rubber plug	1	
20	102.01-20	导线过线套	Magnet cord rubber	1	
21	101.01-21	调线夹线器组件	Thread tension asm.	1	
22	101.01-22	调线夹线螺钉	Thread tension post	1	
23	101.01-23	调线过线板	Thread tension guide	1	
24	101.01-24	小夹线板	Thread tension disk	2	
25	101.01-25	小夹线簧	Thread tension spring	1	
26	101.01-26	小夹线螺母	Thread tension nut	1	
27	02-412280623-1	小夹线器组件螺钉	Screw 3/16x28 L=6	1	
28	102.01-28	挑线杆防护罩	Thread take-up lever cover	1	
29	02-412280623-1	挑线杆护罩螺钉	Screw 3/16x28 L=6	1	
30	102.01-30	右线钩	Arm thread guide Right	1	
31	02-611400621-1	右线钩螺钉	Screw 11/64x40 L=6	1	
32	101.01-32	夹线器组件	Thread tension asm.	1	
33	101.01-33	夹线螺母	Tension nut	1	
34	101.01-34	夹线制动板	Rotating stopper	1	
35	101.01-5	夹线簧	Tension spring	1	
36	101.01-36	夹线板	Thread tension disk presser	1	
37	101.01-37	夹线板	Thread tension disk	2	
38	101.01-38	夹线螺钉	Tension post	1	
39	101.01-39	挑线簧	Take-up spring	1	
40	101.01-40	挑线簧调节座	Tension post socket	1	
41	02-909400421-1	夹线螺钉紧固螺钉	Screw 9/64x40 L=5.5	1	
42	02-815280711-1	夹线器螺钉	Screw 15/64x28 L=7	1	
43	101.01-43	松线钉	Tension releasing	1	
44	101.01-44	针板	Throat plate	1	
45	02-211400621-1	针板螺钉	Screw 11/64x40 L=6	1	
46	02-211400623-1	针板螺钉	Screw 11/64x40 L=6	1	

1.机壳·外装部件

MACHINE FRAME&MISCELLANEOUS COVER COMPONENTS

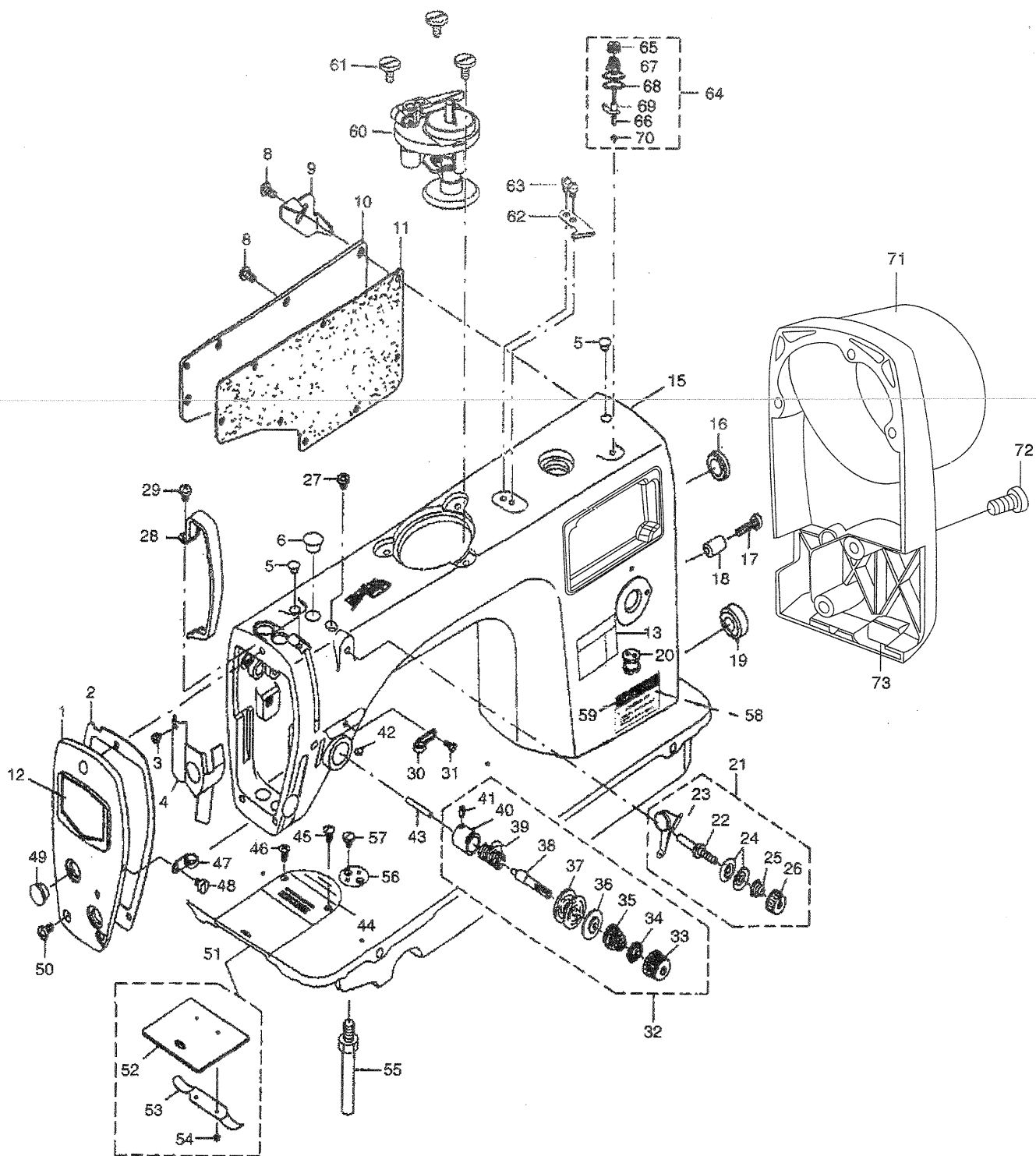

1.机壳·外装部件

序号 Ref. NO.	件号 Part NO.	名称	Description	数量 Qty	备注 Note
47	101.01-47	左线钩	Arm thread guide Left	1	
48	02-611400621-1	左线钩螺钉	Screw 11/64x40 L=6	1	
49	101.01-49	面板调节螺孔塞	Ribber plug	2	
50	02-412280923-1	面板螺钉	Screw 3/16x28 L=9	3	
51	101.01-51	推板部件	Slide plate asm.	1	
52	101.01-52	推板	Slide plate	1	
53	101.01-53	推板簧	Bed slide spring	1	
54	02-606560221-3	推板簧螺钉	Screw 3/32x56 L=2.2	2	
55	102.01-55	底板支柱	Bed screw stud	4	
56	101.01-61	夹边器	Ruler stopper	1	
57	02-911400611-1	夹边器螺钉	Screw 11/64x40 L=6	2	
58	101.01-63	型号牌铆钉	Pole	2	
59	102.01-64-P	型号牌	Model plate	1	
60	102.09-32	绕线器组件	Bobbin base	1	
61	102.09-33	绕线器螺钉	Screw	3	
62	102.09-34	割线刀	Knife	1	
63	102.09-35	割线刀螺钉	Knife screw	2	
64	102.09-36	绕线夹线器组件	Thread tension asm.	1	
65	102.09-36-01	绕线夹线螺母	Tension nut	1	
66	102.09-36-02	绕线夹线螺钉	Tension post	1	
67	102.09-36-03	绕线夹线弹簧	Tension spring	1	
68	102.09-36-04	绕线夹线板	Thread tension disk presser	2	
69	102.09-36-05	绕线过线板	Thread tension guide	1	
70	102.09-36-06	绕线夹线螺母(下)	Tension nut	1	
71	102.11-34	电机罩壳	Motor cover	1	
72	102.11-35	电机罩紧固螺钉	screw	3	

2.上轴·挑线部件

MAIN SHAFT & THREAD-UP LEVER COMPONENTS

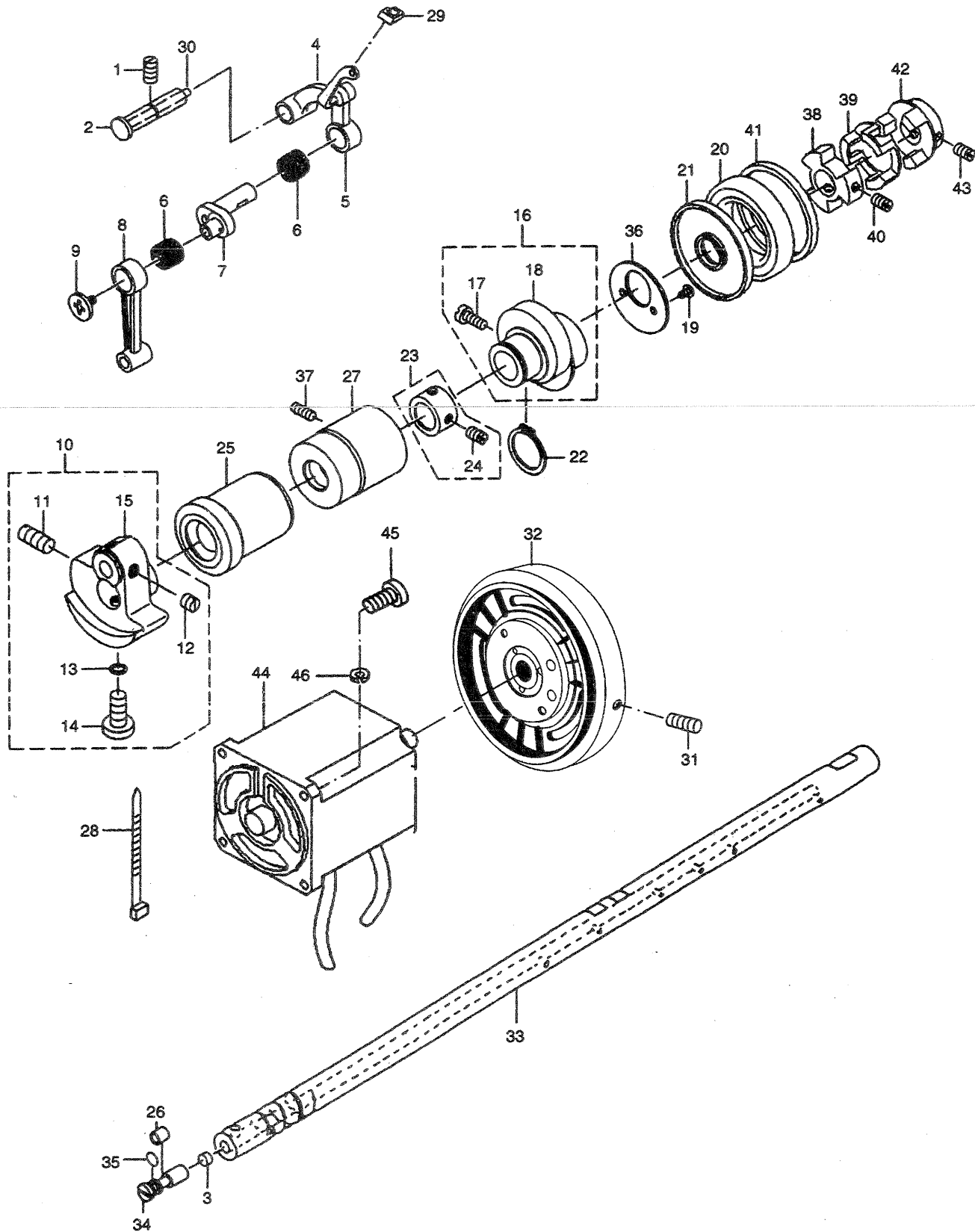

2.上轴·挑线部件

序号 Ref. NO.	件号 Part NO.	名称	Description	数量 Qty	备注 Note
1	02-815281151-1	挑线连杆销螺钉	Screw 15/64x28 L=10.5	1	
2	101.02-02	挑线连杆销	Thread take-up crank shaft	1	
3	101.02-03	曲柄油量限制毡	Roller felt	1	
4	101.02-04	挑线连杆	Thread take-up lever	1	
5	101.02-05	挑线连杆分组件	Thread take-up lever asm.	1	
6	101.02-06	挑线杆滚针轴承	Needle bearing	2	
7	101.02-07	挑线曲柄部件	Needle bar crank	1	
8	101.02-08	针杆连杆	Needle bar crank rod	1	
9	101.02-09	挑线曲柄左旋螺钉	Left screw 9/64x40 L=4.8	1	
10	102.02-10	针杆曲柄组件	Counter weight asm.	1	
11	02-818281651-1	针杆曲柄紧固螺钉	Screw 9/32x28 L=16	1	
12	02-816400611-1	挑线曲柄定位螺钉	Screw 1/4x40 L=6	2	
13	101.02-13	定位螺钉O型圈	Rubber ring	1	
14	02-418281651-1	针杆曲柄定位螺钉	Screw 9/32x28 L=15.5	1	
15	102.02-15	针杆曲柄	Counter weight	1	
16	101.02-16	送料偏心轮组件	Feed drive eccentric cam asm.	1	
17	02-516401111-1	送料偏心轮螺钉	Screw 1/4x40 L=11	2	
18	101.02-18	送料偏心轮	Feed drive eccentric cam	1	
19	02-409400623-1	送料偏心轮盖板螺钉	Screw 9/64x40 L=6	2	
20	102.02-20	轴承	Needle bearing	1	
21	102.02-21	上轴油封	Oil seal	1	
22	101.02-22	拾牙连杆开口挡圈	Snap ring	1	
23	102.02-23	上轴挡圈组件	Thrust collar asm.	1	
24	02-816400611-1	上轴挡圈螺钉	Screw 1/4x40 L=6	2	
25	101.02-25	上轴前轴套	Main shaft front bushing asm.	1	
26	101.02-26	曲柄油量调节销	Oil adjusting collar	1	
27	102.02-27	上轴中轴套	Bushing,intermediate	1	
28	101.02-28	电线夹	Cable band	1	
29	101.02-29	橡皮套	Rubber	1	
30	101.02-30	挑线连杆销毛毡	Thread take-up crank shaft felt	1	
31	02-815281051-1	手轮螺钉	Screw 15/64x28 L=10	1	
32	102.02-34	手轮	Hand wheel	1	
33	102.02-38	上轴	Main shaft	1	
34	101.02-40	上轴油量调节销	Oil amount adjusting pin	1	
35	101.02-41	上轴油量调节销O型圈	Rubber ring	1	
36	101.02-42	送料偏心轴盖板	Thrust collar	1	
37	102.02-43	上轴中轴套螺钉	Screw	1	
38	102.02-44	连轴器(A)	Connect block A	1	
39	102.02-45	连轴器橡胶圈	Connect rubber A	1	
40	102.02-46	连轴器螺钉	Screw	3	
41	102.02-47	轴承垫	Needle bearing plate	1	
42	102.02-48	连轴器(B)	Connect block B	1	
43	102.02-49	连轴器(B)固定螺钉	Screw	3	
44	102.11-36	直驱电机组件	Motor asm.	1	
45	102.11-37	电机安装螺钉	Screw	4	
46	102.11-38	电机安装螺钉垫片	Washer	4	

3. 针杆 · 竖轴 · 下轴部件

NEEDLE BAR, UPRIGHT SHAFT & HOOK DRIVING SHAFT COMPONENTS

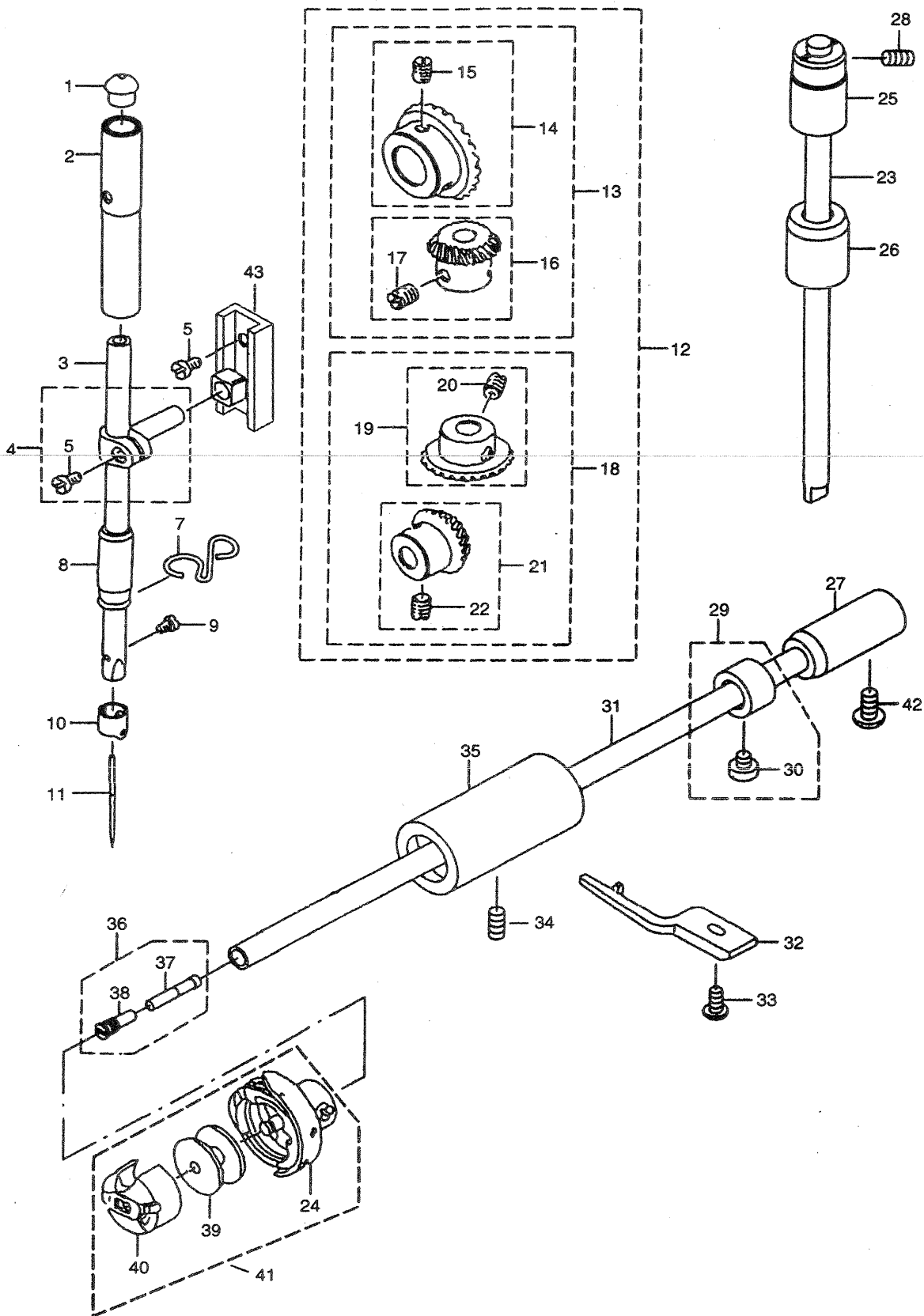

3.针杆·竖轴·下轴部件

序号 Ref. NO.	件号 Part NO.	名称	Description	数量 Qty	备注 Note
1	102.03-01	针杆上孔塞	Cap	1	
2	102.03-02	针杆上套	Needle bar bushing upper	1	
3	102.03-03	针杆	Needle bar	1	
4	102.03-04	针杆连接柱组件	Needle rod holder asm.	1	
5	02-509400821-1	针杆连接柱螺钉	Screw 9/64x40 L=7.5	3	
6	102.03-06	针杆连接柱滑块	Slide block	1	
7	102.03-07	针杆下套线钩	Needle bar thread guide	1	
8	102.03-08	针杆下套	Needle bar bushing,lower	1	
9	02-508440521-1	机针螺钉	Screw 1/8x44 L=4.8	1	
10	102.03-10	针杆线钩	Needle bar thread guide	1	
11	101.03-11	机针	Needle DBX1 #14	1	
12	101.03-12	伞齿轮组件	Gear&pinion asm.	1	
13	101.03-13	上齿轮组件	Gear&pinion asm.,upper	1	
14	101.03-14	上轴伞齿轮组件	Gear asm.	1	
15	02-816400811-1	伞齿轮螺钉	Screw 1/4x40 L=8	2	
16	101.03-16	竖轴上伞齿轮组件	Pinion asm.	1	
17	02-816400811-1	伞齿轮螺钉	Screw 1/4x40 L=8	2	
18	101.03-18	下齿轮组件	Gear&pinion asm.,lower	1	
19	101.03-19	竖轴下齿轮组件	Gear asm.	1	
20	02-816400811-1	伞齿轮螺钉	Screw 1/4x40 L=8	2	
21	101.03-21	下轴伞齿轮组件	Pinion asm.	1	
22	02-816400811-1	伞齿轮螺钉	Screw 1/4x40 L=8	2	
23	102.03-23	竖轴	Upright shaft	1	
24	101.03-24	旋梭	Hook asm.	1	
25	102.03-25	竖轴上轴套	Upright shaft bushing,upper	1	
26	102.03-26	竖轴下轴套	Upright shaft bushing,lower	1	
27	102.03-27	下轴后轴套	Bushing rear	1	
28	02-812280711-1	竖轴上套紧固螺钉	Screw 3/16x28 L=7	1	
29	102.03-29	下轴挡圈组件	Thrust collar asm.	1	
30	02-511400511-1	下轴挡圈螺钉	Screw 11/64x40 L=5	2	
31	102.03-31	下轴	Lower shaft	1	
32	101.03-32	旋梭定位钩	Bobbin case holder	1	
33	02-511401021-1	旋梭定位钩螺钉	Screw 11/64x40 L=9.5	1	
34	02-812280711-1	下轴前轴套螺钉	Screw 3/16x28 L=7	1	
35	102.03-35	下轴前轴套	Lower shaft front metal	1	
36	101.03-38	下轴限油组件	Oil seal screw asm.	1	
37	101.03-39	下轴限油芯	Oil wick	1	
38	101.03-40	下轴限油螺钉	Oil seal screw	1	
39	101.03-41	梭心	Bobbin	1	
40	101.03-42	梭壳	Bobbin case	1	
41	101.03-43	旋梭梭壳组件	Hook bobbin case asm.	1	
42	02-612281311-1	下轴后轴套螺钉	Screw 3/16x28 L=13	1	
43	101.03-46	针杆连接柱滑块座	Slide block base	1	

4.压杆部件

HAND LIFTER COMPONENTS

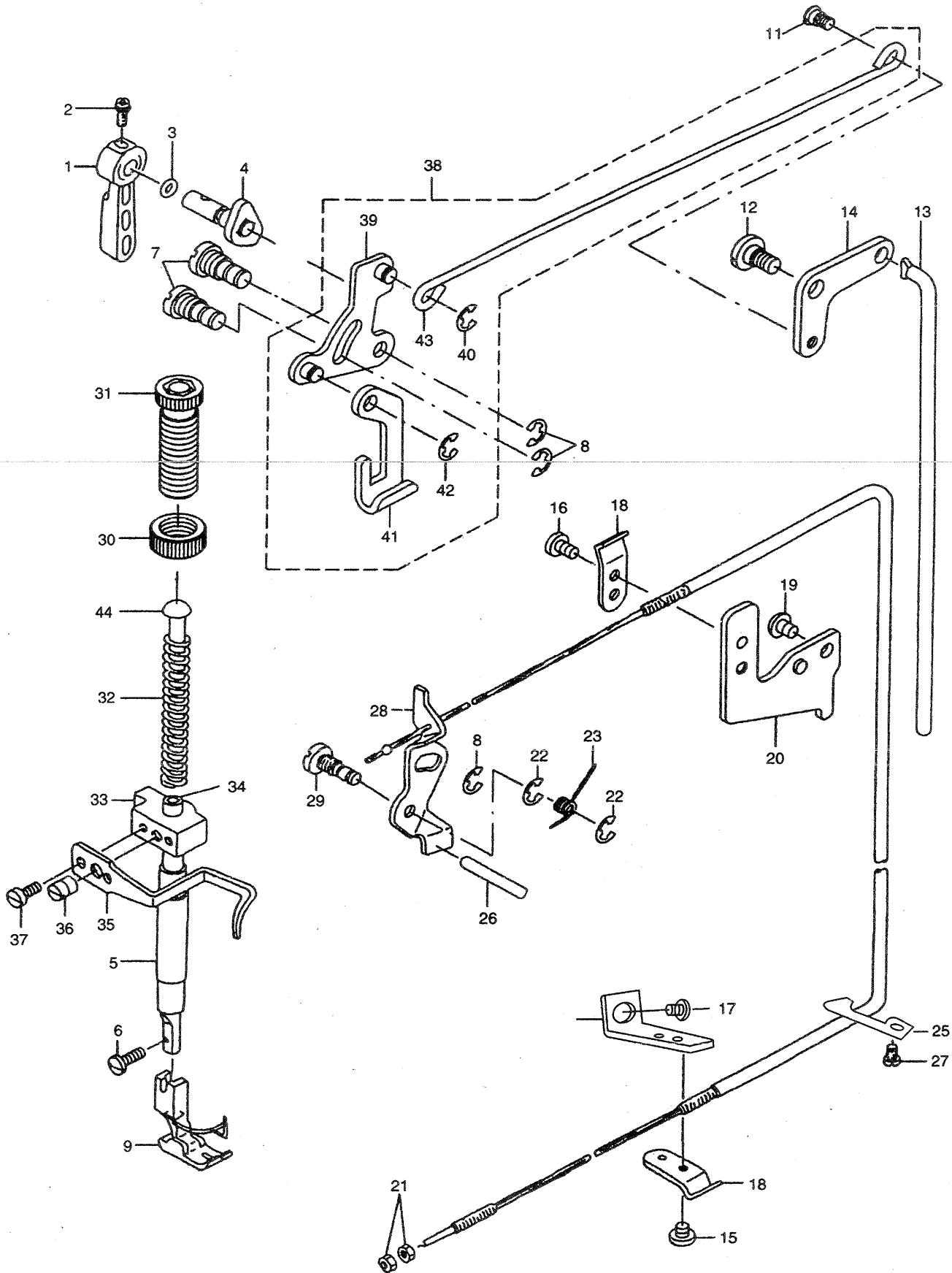

4.压杆部件

序号 Ref. NO.	件号 Part NO.	名称	Description	量 Qty	备注 Note
1	101.04-01	压脚扳手	Hand lifter	1	
2	02-509401023-1	压脚扳手螺钉	Screw 9/64x40 L=10	1	
3	101.04-03	压脚扳手轴O型圈	Rubber ring	1	
4	102.04-04	压脚扳手凸轮部件	Hand lifter cam asm.	1	
5	102.04-05	压杆轴套	Presser bar bushing lower	1	
6	02-409400821-1	活压脚螺钉	Screw 9/64x40 L=8	1	
7	102.04-07	前杠杆螺纹销	Link shaft	2	
8	101.04-08	螺纹销开口挡圈	E-ring 5	3	
9	101.04-09	活压脚部件	Presser foot asm.	1	
10	102.04-10	下压线底板	Wire holder bracket,lower	1	
11	102.04-11	拾压脚拉杆螺钉	Hinge screw	1	
12	102.04-12	后杠杆轴拉螺钉	Hinge screw	1	
13	102.04-13	拾压脚顶杆	Knee lifter connecting rod	1	
14	102.04-14	拾压脚后杠杆	Lifting lever link	1	
15	02-411400521-1	下压板紧固螺钉	Screw 11/64x40 L=5	1	
16	02-411400521-1	上压板紧固螺钉	Screw 11/64x40 L=5	1	
17	02-515281521-1	下压板组件紧固螺钉	Screw 15/64x28 L=14.5	1	
18	102.04-18	拉线活压板	Wire holder	2	
19	02-412280623-1	上压板组件紧固螺钉	Screw 3/16x28 L=6	1	
20	102.04-20	上压线底板	Wire holder bracket,upper	1	
21	04-612320400-1	拉线钮距调节螺母	Nut 3/16x32	2	
22	101.04-22	螺纹销开口挡圈	E-ring 5	2	
23	101.04-23	松线顶板复位簧	Tension release return spring	1	
25	102.04-25	软管右挡板	Wire cable holder	1	
26	102.04-26	松线辅钉	Tension release supporting pin	1	
27	02-412280623-1	右挡板紧固螺钉	Screw 3/16x28 L=6	1	
28	102.04-28	松线顶板	Thread tension release wire	1	
29	102.04-29	松线顶板螺纹销	Tension release shaft	1	
30	102.04-30	调压螺母	Presser adjusting screw nut	1	
31	102.04-31	调压螺钉	Presser spring regulator	1	
32	102.04-32	调压簧	Presser adjusting spring	1	
33	102.04-33	压杆导架	Presser bar guide bracket	1	
34	101.04-35	压杆	Presser bar	1	
35	102.04-36	缓线调节钩	Presser bar thread guide	1	
36	02-816400811-1	压杆导架螺钉	Screw 1/4x40 L=8	1	
37	02-509400821-1	缓线调节钩螺钉	Screw 9/64x40 L=8	2	
38	102.04-39	前杠杆组件	Knee lifting cross rod asm	1	
39	102.04-40	拾压脚前杠杆部件	Hand lifter link	1	
40	102.04-41	拉杆开口挡圈	E-ring 5	1	
41	102.04-42	压脚升降板	Lifting lever	1	
42	102.04-43	升降板连接开口挡圈	E-ring 5	1	
43	102.04-44	拾压脚拉杆	Knee lifting cross rod	1	
44	102.04-45	调压导杆	Presser guide bar	1	

5.送料部件

FEED MECHANISM COMPONENTS

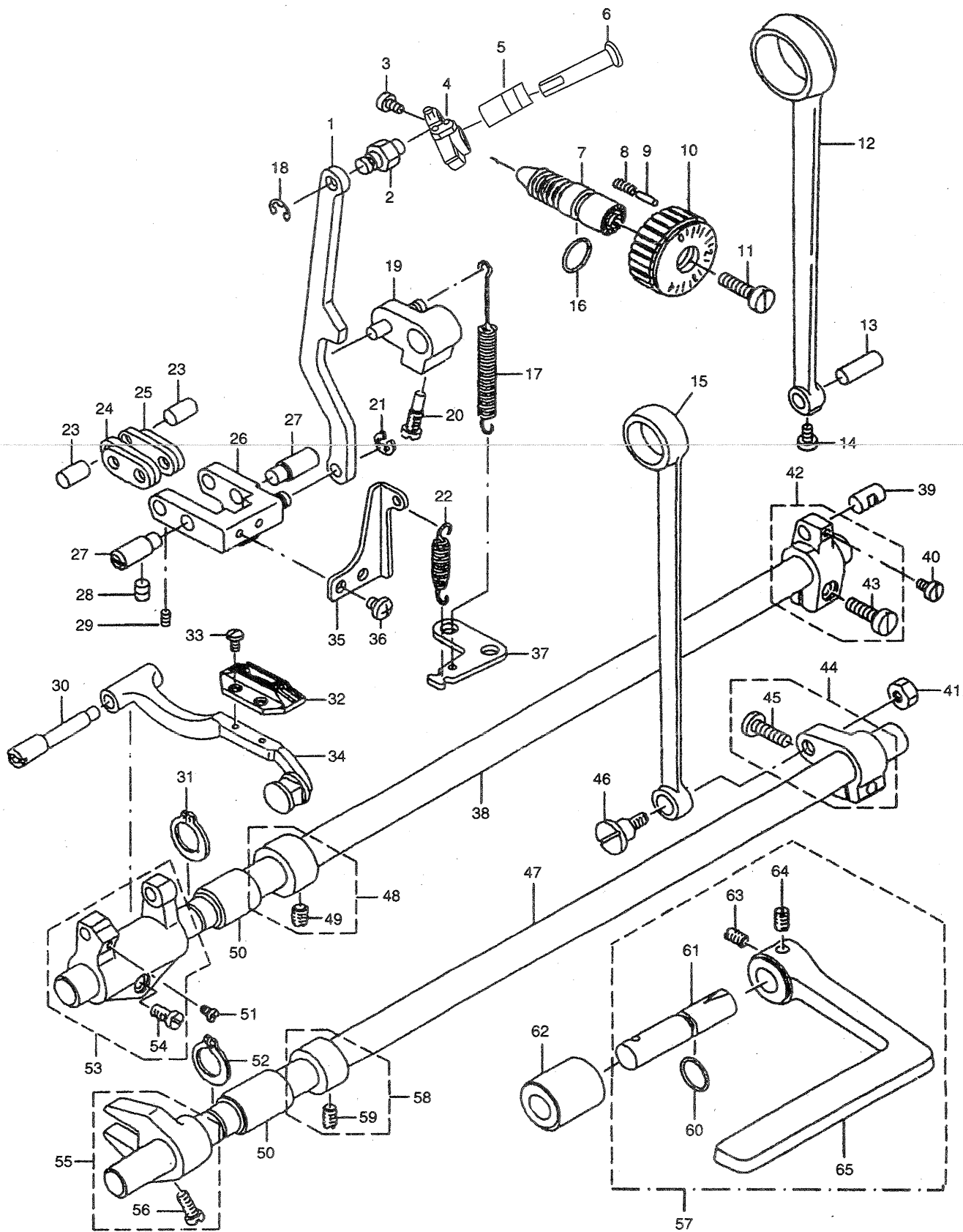

5.送料部件

序号 Ref. NO.	件号 Part NO.	名称	Description	数量 Qty	备注 Note
1	102.05-01	倒送料连杆	Feed adjust rod	1	
2	102.05-02	倒送料连杆销	Feed regulator pin	1	
3	02-509400621-1	连杆销螺钉	Screw 9/64x40 L=6	2	
4	101.05-04	送料调节器	Feed regulator	1	
5	101.05-05	送料调节器轴套	Feed regulator bushing	1	
6	02-312280721-1	送料调节器紧固螺钉	Screw 3/16x28 L=7	1	
7	102.05-07	送料调节螺栓	Feed regulator screw	1	
8	102.05-08	送料距锁合簧	Spring	1	
9	102.05-09	送料距锁合销	Feed adjust pin	1	
10	102.05-10	送料距旋钮	Feed dial	1	
11	02-512281821-1	送料距旋钮螺钉	Screw 3/16x28 L=18	1	
12	102.05-12	送料连杆	Rocker shaft connecting rod	1	
13	102.05-13	送料连杆销	Walking foot long pin	1	
14	02-809400424-1	送料连杆螺钉	Screw 9/64x40 L=4	1	
15	102.05-15	抬牙连杆	Connecting rod	1	
16	102.05-16	送料调节螺栓O型圈	Rubber ring	1	
17	102.05-17	摆动板复位簧	Feed reverse spring	1	
18	101.05-18	倒送料连杆销挡圈	E-ring 5	1	
19	102.05-19	倒送料曲柄组件	Feed reverse arm asm.	1	
20	102.05-20	倒送料曲柄螺钉	Screw	1	
21	101.05-21	倒送料连杆挡圈	E-ring 5	1	
22	102.05-22	倒送料拉簧	Spring	1	
23	102.05-23	短摆动板连接销	Walking foot short pin	2	
24	102.05-24	送料长摆动板	Connecting link long pin	2	
25	102.05-25	送料短摆动板	Connecting link short pin	2	
26	102.05-26	送料摆动板座组件	Feed adjust link asm.	1	
27	102.05-27	送料摆动板座左右销	Adjusting link fulcrum shaft	2	
28	02-815280711-1	左右销螺钉	Screw 15/64x28 L=7	2	
29	02-809400424-1	连杆销螺钉	Screw 9/64x40 L=4	2	
30	102.05-30	牙架销	Feed bar shaft	1	
31	102.05-31	送料轴轴用挡圈	Retaining ring	1	
32	101.05-32	送料牙	Feed dog I	1	
33	02-608440621-1	送料牙螺钉	Screw 1/8x44 L=6	2	
34	102.05-34	牙架部件	Feed bar asm.	1	
35	101.05-35	摆动板复位板	Adjusting link spring guide	1	
36	02-411400523-1	复位板紧固螺钉	Screw 11/64x40 L=5	2	
37	102.05-37	拉簧固定板	Feed spring hood	1	
38	102.05-38	送料轴	Feed rocker shaft	1	
39	102.05-39	送料曲柄销	Walking foot middle pin	1	
40	02-509400621-1	曲柄销螺钉	Screw 9/64x40 L=6	1	
41	04-618280400-1	抬牙连杆轴位螺母	Nut 9/32x28	1	
42	101.05-42	送料曲柄组件	Feed rocker shaft crank asm.	1	
43	02-412281621-1	送料曲柄螺钉	Screw 3/16x28 L=15.5	1	
44	102.05-44	抬牙后曲柄组件	Lifting rocker asm.	1	
45	02-412281421-1	抬牙后曲柄螺钉	Screw 3/16x28 L=14	1	
46	102.05-46	抬牙连杆轴位螺钉	Hinge screw	1	

5.送料部件

FEED MECHANISM COMPONENTS

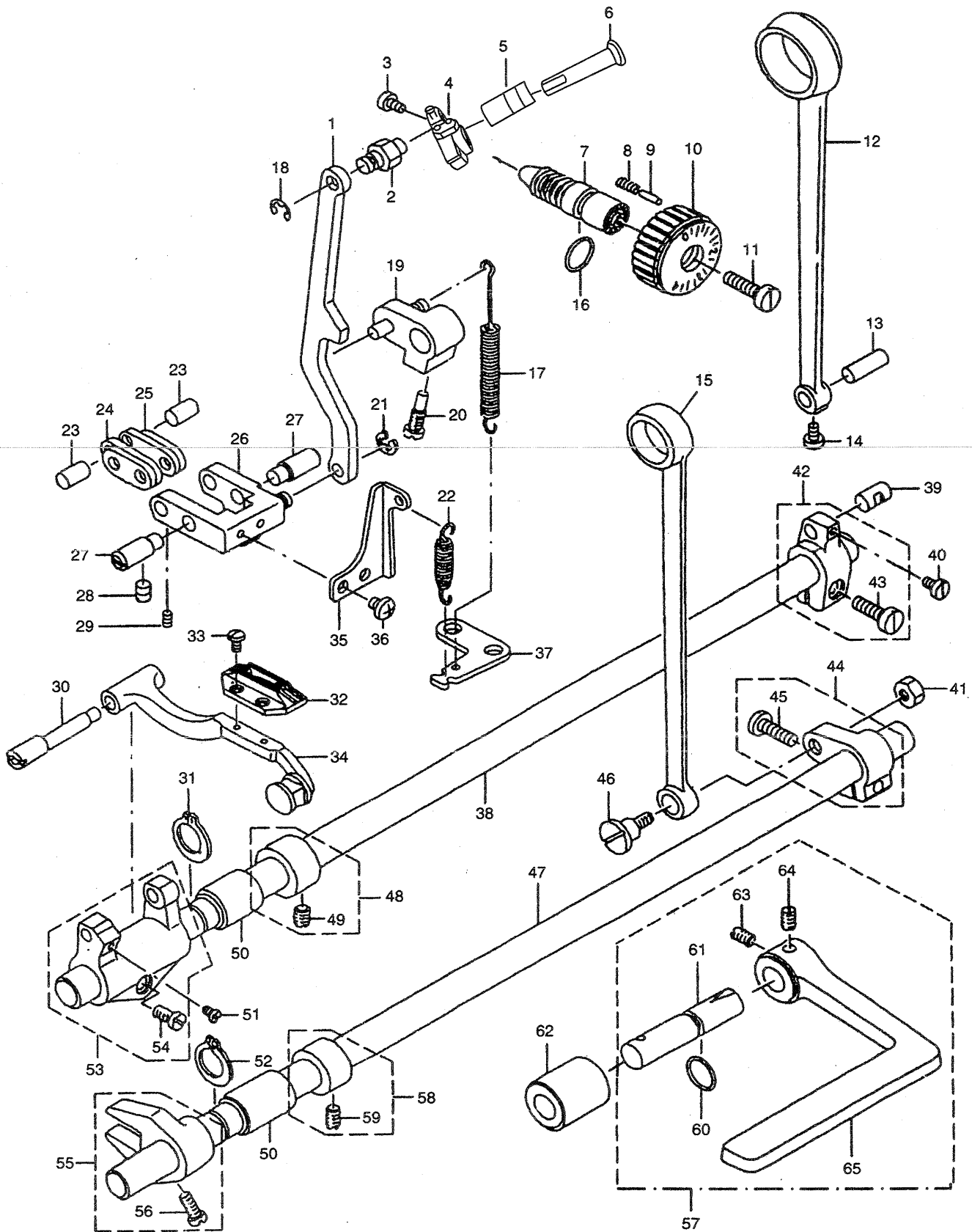

5.送料部件

序号 Ref. NO.	件号 Part NO.	名称	Description	数量 Qty	备注 Note
47	102.05-47	拾牙轴	Feed driving shaft	1	
48	102.05-48	拾牙轴挡圈组件	Thrust collar asm.	1	
49	02-816400611-1	送料轴挡圈螺钉	Screw 1/4x40 L=6	1	
50	102.05-49	送料轴前轴套	Feed rocker shaft bushing	2	
51	02-411400721-1	牙架销螺钉	Screw 11/64x40 L=7	2	
52	102.05-50	拾牙轴轴用挡圈	Retaining ring	1	
53	102.05-51	牙架座组件	Feed bar crank asm.	1	
54	02-412281421-1	牙架座螺钉	Screw 3/16x28 L=14	1	
55	102.05-52	拾牙叉曲柄组件	Driving shaft crank asm.	1	
56	02-511401121-1	拾牙叉曲柄螺钉	Screw 11/64x40 L=10.5	1	
57	102.05-59	倒送料扳手组件	Reverse feed control lever asm.	1	
58	102.05-61	拾牙轴挡圈	Thrust collar asm.	1	
59	02-816400611-1	拾牙轴挡圈螺钉	Screw 1/4x40 L=6	2	
60	102.05-63	倒送料轴O型圈	Rubber ring	1	
61	102.05-64	倒送料轴	Feed reverse shaft	1	
62	102.05-65	倒送料轴轴套	Feed lever metal	1	
63	02-816400911-1	倒送料扳手螺钉	Screw 1/4x40 L=8.5	1	
64	02-816401041-1	倒送料扳手定位螺钉	Screw 1/4x40 L=10	1	
65	102.05-68	倒送料扳手	Reverse feed control lever	1	

6.自动切线部件

THREAD TRIMMER COMPONENTS

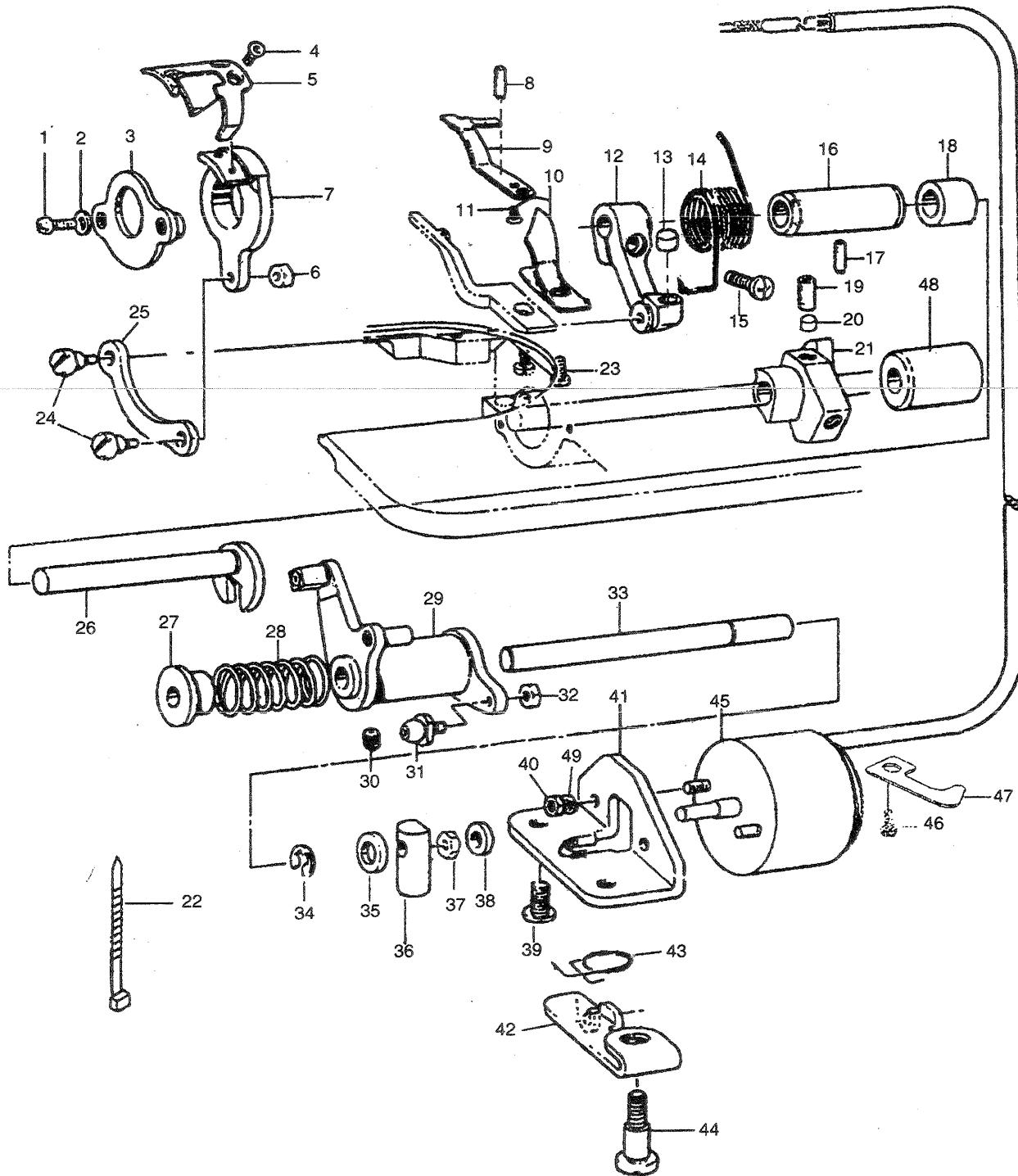

6.自动切线部件

序号 Ref. NO.	件号 Part NO.	名称	Description	数量 Qty	备注 Note
1	101.13-02	螺钉SM11/64"x40 L=12	Screw SM11/64x40 L=12	2	
2	101.13-10	牙架座螺钉垫圈	Washer	2	
3	101.13-07	刀架压板组件	Partiality shank asm.	1	
4	101.13-08	活动刀固定螺钉	Screw	2	
5	101.13-03	活动刀	Motorial knife	1	
6	101.13-04	螺母 SM11/64"x40	Nut SM11/64x40	1	
7	101.06-06	剪线刀架	Knife bracket	1	
8	02-206560321-1	定刀调节螺钉	Screw	1	
9	101.13-12	割线刀	Secant knife	1	
10	101.13-05	护针片	Protect needle patch	1	
11	101.13-06	螺钉 SM9/64"x40 L=4	Screw SM9/64x40 L=4	1	
12	02-611401021-1	曲柄	Thread shear rock arm	1	
13	101.06-13	驱动曲柄止动块	Positioning block	1	
14	101.06-14	弹簧	Spring	1	
15	101.06-15	螺钉 SM3/16"x32 L=14	Screw SM3/16x32 L=14	2	
16	02-409400523-1	切线轴套	Thread shear cam rock arm assy	1	
17	101.06-17	螺钉 SM11/64"x40	Screw SM11/64x40	1	
18	101.06-18	驱动曲柄轴衬套	Short bush	1	
19	101.06-19	螺钉 SM1/4"x40 L=10	Serew SM1/4x40 L=10	1	
20	02-916400611-1	凸轮顶柱	Pole	2	
21	101.06-21	凸轮	Thread shear cam	1	
22	02-811400511-1	尼龙扎带	Bale band	1	
23	101.06-23	螺钉 SM9/64"x40 L=5	Screw SM9/64x40 L=5	1	
24	101.06-24	连杆螺钉 SM11/64"x40 L=5.5	Screw SM11/64x40 L=5.5	2	
25	101.06-25	连杆	Knife shaft connecting rod	1	
26	101.06-26	切线凸轮曲柄轴	Thread shear rock arm shaft	1	
27	101.06-7	扭簧端盖	Spring cover	1	
28	02-611400621-1	弹簧	Spring	1	
29	101.06-29	剪线驱动组件	Thread shear rock arm shaft	1	
30	101.06-30	螺钉 SM11/64"x40	Screw SM11/64x40	1	
31	101.06-31	滚柱	Rool shaft assy	1	
32	101.06-32	螺母	Nut	1	
33	101.06-33	轴	Thread shear shaft	1	
34	101.06-34	挡圈	Retaining ring	1	
35	101.06-35	电磁铁缓冲垫	Magnetic plug cushion mat	1	
36	101.06-36	切线电磁铁顶梢	Magnetic plug pin	1	
37	101.06-37	螺母 SM1/4"x40	Nut SM1/4x40	1	
38	101.06-38	垫圈	Washer	1	
39	101.06-39	油泵安装螺钉	Screw	1	
40	101.06-40	螺母 M4	Nut M4	2	
41	101.06-41	切线磁铁支架	Magnetic plug cushion mat	1	
42	02-409400623-1	松线座	Thread loose seat	1	
43	101.06-43	弹簧	Spring	1	
44	101.06-44	螺钉 SM1/4"x28 L=13	Screw SM1/4x28 L=13	1	
45	101.06-45	剪线电磁铁组件	Magnetic plug	1	
46	101.06-46	螺钉 SM15/64"x28 L=14.5	Screw SM15/64x28 L=14.5	1	
47	02-415280923-1	旋梭供油管压板	Electrical plug breacker washer	1	
48	101.06-48	下轴中套	Bushing,lower shaft	1	
49	101.06-49	垫圈4.5x8x0.5	Washer 4.5x8x0.5	2	

7. 自动倒缝部件

AUTOMATIC REVERSE FEED COMPONENTS

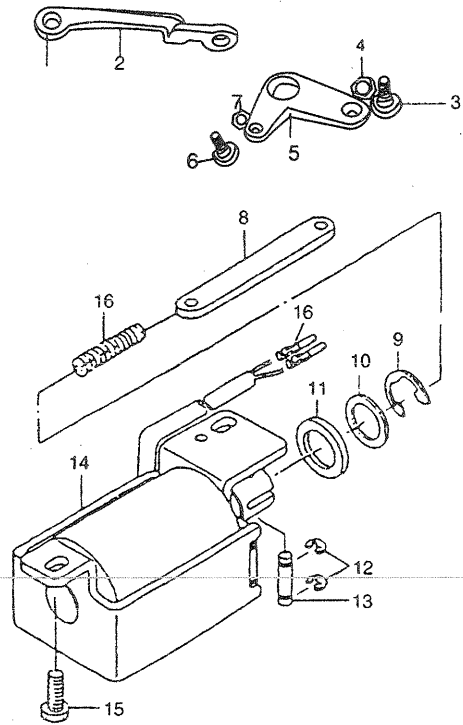
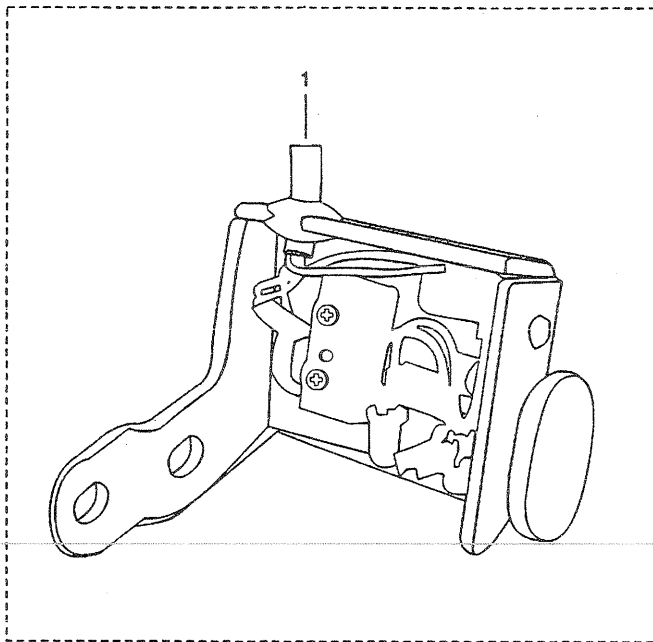

8. 电子夹线器，选针盒部件 ELECTRONIC CONDUCTOR HOLDER

NEEDLE SELECTION BOX COMPONENTS

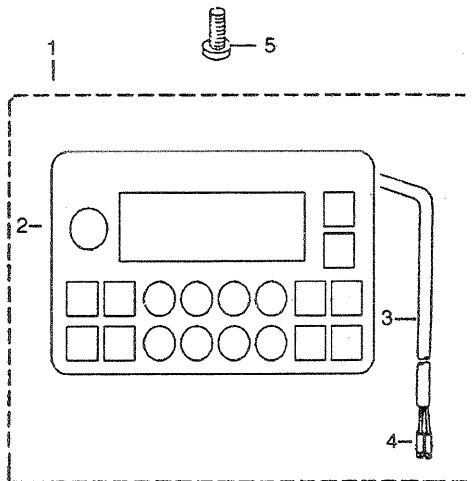

A款

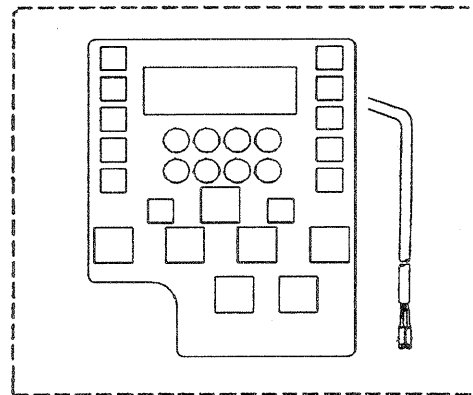

B款

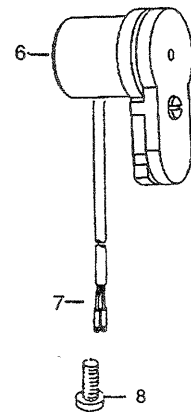

7.自动倒缝部件

序号 Ref. NO.	件号 Part NO.	名称	Description	数量 Qty	备注 Note
1	101.07-01	自动倒缝开关组件	Reverse feed switch asm.	1	
2	101.07-02	自动倒缝拉杆	Automatic reverse stitching rods	2	
3	101.07-03	自动倒缝拉杆螺钉	Automatic reverse stitching bars screws	1	
4	101.07-04	自动倒缝拉杆螺母	Automatic reverse stitching bars nut	1	
5	101.07-05	倒缝曲柄	Reverse stitching crank down	1	
6	101.07-06	倒缝曲柄螺钉	Scam crank screws	1	
7	101.07-07	倒缝曲柄螺钉	Reverse stitching crank screws	1	
8	101.07-08	倒缝铁芯连杆	Reverse feed connecting link	1	
9	101.07-09	倒缝铁芯挡圈	E-ring 20	1	
10	101.07-10	垫片	Washer 16x24x2.6	1	
11	101.07-11	橡胶垫片	Rubber plunger	1	
12	101.07-12	连接销卡簧	E-ring 4	2	
13	101.07-13	倒缝铁芯连接销	Plunger arm pin	1	
14	101.07-14	倒缝电磁铁	Reverse feed magnet asm.	1	
15	101.07-15	电磁铁紧固螺钉	Screw 15/64x28 L=12	2	
16	101.07-16	连杆定位簧	Plunger spring	1	

8.电子夹线器，选针盒部件

序号 Ref. NO.	件号 Part NO.	名称	Description	数量 Qty	备注 Note
1	101.08-01	选针盒组件	Needle selection box asm	1	
2	101.08-02	选针盒	Needle selection box	1	
3	101.08-03	电线	2-core cabtyre cord	1	
4	101.08-04	插针	pin contact	1	
5	101.08-05	选针盒固定螺钉	Screw SM9/64X40 L=8	3	
6	101.08-06	电子夹线器组件	Electronic conductor holder asm	1	
7	101.08-07	插针	Contact pin	1	
8	101.08-08	电子夹线器固定螺钉	Screw SM3/16X28 L=6	1	

9. 润滑部件

OIL LUBRICATION COMPONENTS

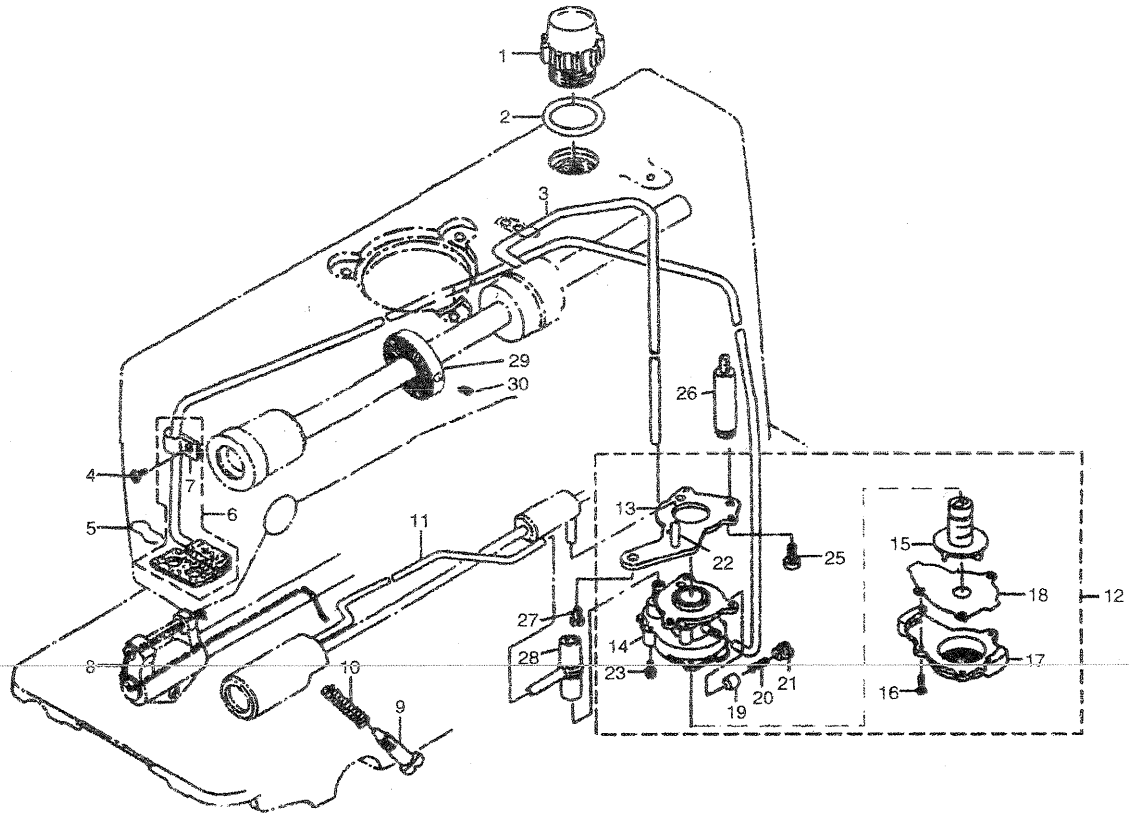

10. 油盘部件

OIL RESERVOIR COMPONENTS

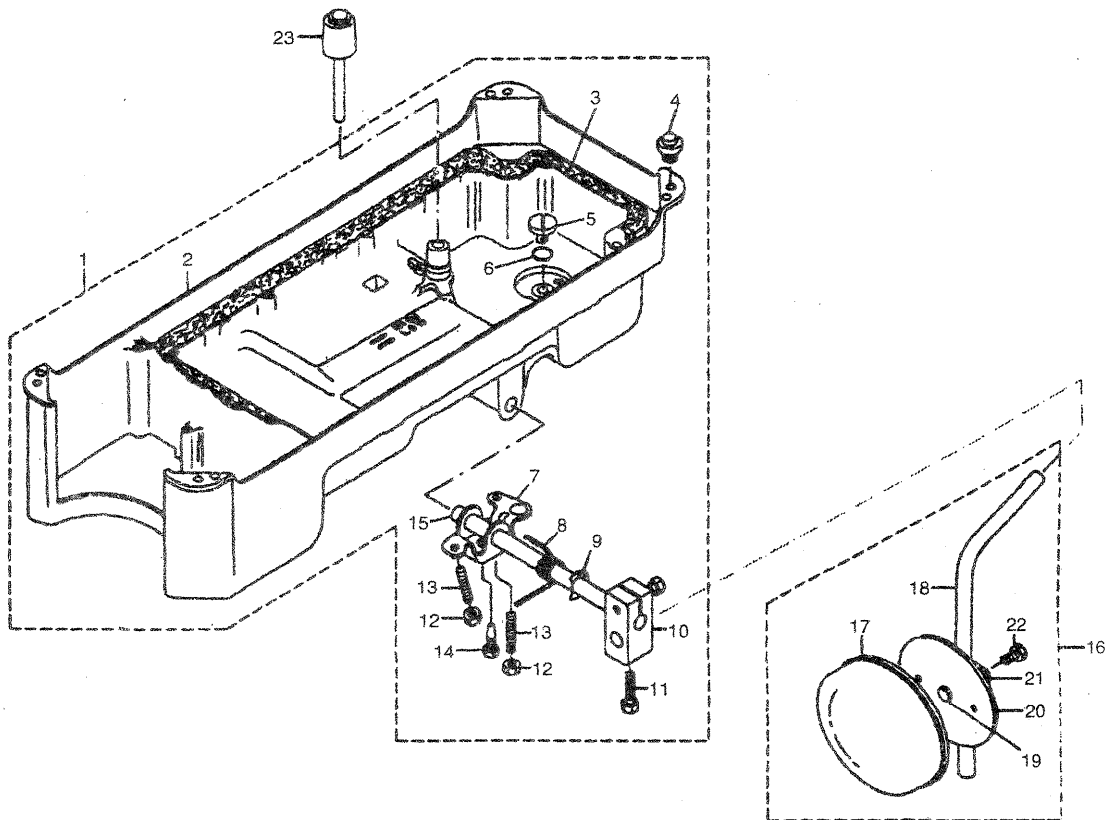

9. 润滑部件

序号 Ref. NO.	件号 Part NO.	名称	Description	数量 Qty	备注 Note
1	102.09-01	油窗	Oil sight window	1	
2	102.09-02	油窗O型圈	Rubber ring	1	
3	102.09-03	上轴供油管	Main shaft oil tube	1	
4	02-412280623-1	回油管夹螺钉	Screw 3/16x28 L=6	1	
5	102.09-05	回油毡夹	Oil felt presser	1	
6	102.09-06	回油管组件	Oil return tube asm	1	
7	102.09-07	回油管夹	Holder	1	
8	101.09-08	送料轴油线	Oil wick	1	
9	102.09-09	旋梭油量调节螺钉	Oil adjusting screw	1	
10	102.09-10	旋梭油量调节簧	Spring	1	
11	102.09-11	旋梭供油管	Oil tube	1	
12	101.09-12	油泵部件	Lubricating oil pump asm	1	
13	101.09-13	油泵安装板	Oil pump installing base	1	
14	101.09-14	油泵体	Oil pump	1	
15	101.09-15	油泵叶轮	Oil pump impeller	1	
16	101.09-16	油泵盖螺钉	Screw D=3 L=10	3	
17	101.09-17	油泵盖	Lubricating oil pump cover	1	
18	101.09-18	油泵叶轮托板	Oil pump impeller cover	1	
19	101.09-19	回油柱塞	Plunger	1	
20	101.09-20	柱塞簧	Plunger spring	1	
21	101.09-21	柱塞螺钉	Plunger screw	1	
22	101.09-22	下轴供油管	Hook driving shaft oil tube	1	
23	101.09-23	油泵安装螺钉	Screw M3 L=8	3	
24	02-611401021-1	螺柱连接螺钉	Screw 11/64x40 L=9.5	1	
25	101.09-26	油泵连接螺柱	Oil pump support, large	1	
26	02-615281221-1	油泵螺钉	Screw 15/64x28 L=12	1	
27	101.09-28	供油管接头	Rubber joint	1	
28	102.09-37	绕线器驱动轮	Bobbin pulley	1	
29	102.09-38	绕线器驱动轮螺钉	Screw	2	

10. 油盘部件

1	101.10-01	油盘部件	Oil reservoir asm	1	
2	101.10-02	油盘	Oil reservoir	1	
3	101.10-03	油盘垫	Oil reservoir gasket	1	
5	02-620240721-1	排油孔螺钉	Screw 5/16x24 L=7	1	
6	101.10-06	排油孔螺钉O型圈	Rubber ring	1	
7	101.10-07	抬压脚双向曲柄	Knee lifting rotating arm	1	
8	101.10-08	双向曲柄扭簧	Spring	1	
9	101.10-09	抬压脚轴开口挡圈	E-ring 10	1	
10	101.10-10	抬压脚操纵杆节头	Vertical shaft fitting arm	1	
11	101.10-11	操纵杆节头螺钉	Screw	2	
12	101.10-12	双向曲柄限位调节螺母	Nut M6	2	
13	101.10-13	双向曲柄限位调节螺钉	Screw M6 L=30	2	
14	101.10-14	双向曲柄螺钉	Screw M6 L=17.5	1	
15	101.10-15	抬压脚轴	Knee press cross shaft	1	
16	101.10-16	操纵杆部件	Knee pan plate asm	1	
17	101.10-17	操纵杆软垫	Knee pan plate cover	1	
18	101.10-18	操纵杆	Knee pan upright shaft	1	
19	101.10-19	操纵杆垫	Knee pan plate rubber	1	
20	101.10-20	操纵板	Knee pan plate	1	
21	101.10-21	操纵杆节头	Knee pan plate support	1	
22	101.10-22	节头螺钉	Screw M6 L=12	1	
23	101.10-23	抬压脚顶销	Knee lifter push rod	1	

11.过线架部件

THREAD STAND COMPONENTS

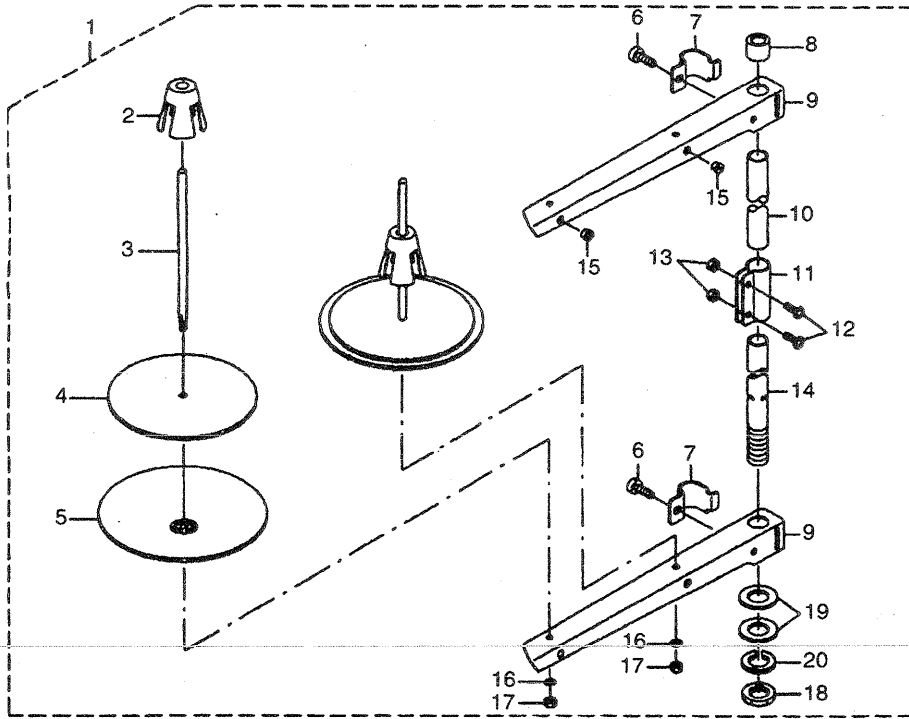

12.附件

ACCESSORIES

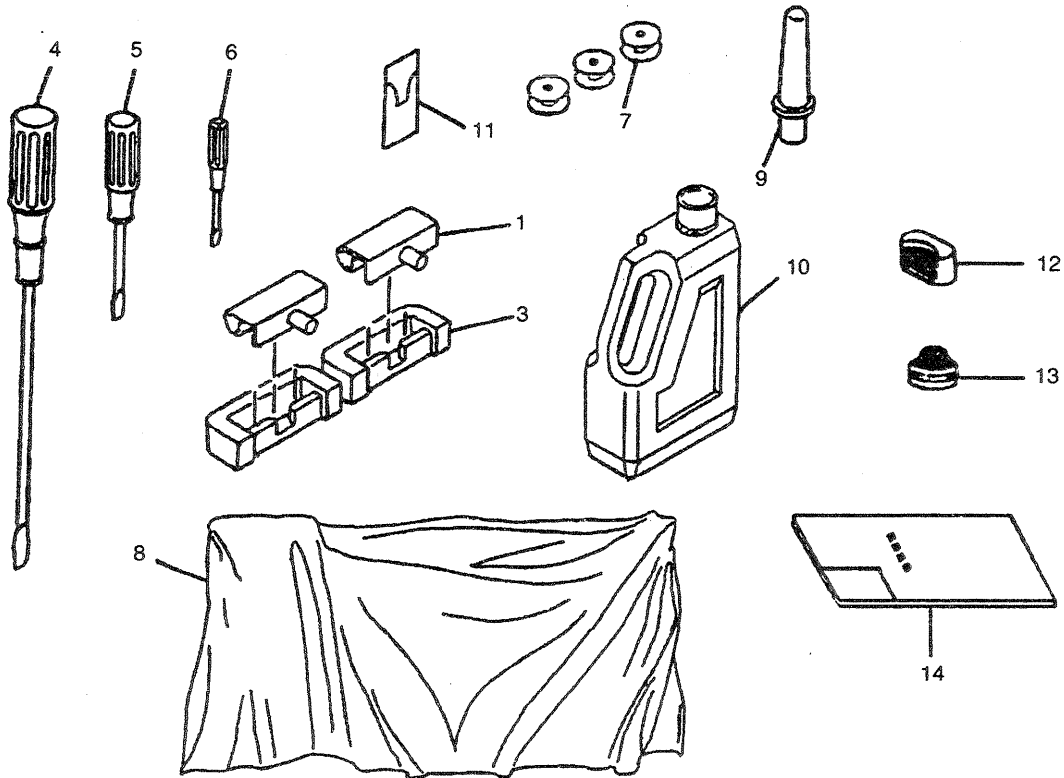

11.过线架部件

序号 Ref. NO.	件 号 Part NO.	名 称	Description	数 量 Qty	备注 Note
1	101.12-01	过线架部件	Thread stand asm.	1	
2	101.12-02	线团防松垫	Spool retainer	2	
3	101.12-03	线盘钉	Spool pin	2	
4	101.12-04	线盘轮垫	Spool rest cushion	2	
5	101.12-05	线盘	Spool rest	2	
6	101.12-06	线架过线夹螺钉	Screw M6 L=16	2	
7	101.12-07	线架过线夹	Thread guide arm joint	2	
8	101.12-08	线架杆顶防护橡皮	Spool rest rod rubber cap	1	
9	101.12-09	线架过线杆	Spool rest arm	2	
10	101.12-10	线架杆上节	Spool rest rod,upper	1	
11	101.12-11	接架杆接头	Spool rest rod joint	1	
12	101.12-12	接架杆接头螺钉	Screw M5 L=14	2	
13	101.12-13	接架杆接头螺母	Nut M5	2	
14	101.12-14	线架杆下节	Spool rest rod,lower	1	
15	101.12-15	过线圈	Thread guide	2	
16	101.12-16	线盘钉弹簧垫	Spring washer	2	
17	101.12-17	线盘钉螺母	Nut M5	2	
18	101.12-18	线架杆紧固螺母	Nut M16x1.5	1	
19	101.12-19	线架杆紧固螺母垫圈	Washer 16x30x2.6	2	
20	101.12-20	紧固螺母弹簧的垫圈	Spring washer	1	

12.附件

序号 Ref. NO.	件 号 Part NO.	名 称	Description	数 量 Qty	备注 Note
1	101.14-01	机头连接钩组件	Machine hinge plate asm.	2	
3	101.14-03	机头连接钩座	Machine hinge plate	2	
4	101.14-04	螺丝刀(大)	Screw driver,large	1	
5	101.14-05	螺丝刀(中)	Screw driver,mendium	1	
6	101.14-06	螺丝刀(小)	Screw driver,small	1	
7	101.14-07	梭心	Bobbin	3	
8	101.14-08	机头罩	Macgube head cover	1	
9	101.14-09	机头支柱	Macgube rest cover	1	
10	101.14-10	油箱部件	Oil reservoir asm.	1	
11	101.14-11	机针	Needle DBx1 #14	1包	
12	101.14-12	防震垫(A)	quakeproof washer A	1	
13	101.14-13	防震垫(B)	quakeproof washer B	1	
14	101.14-14	说明书	Instruction book	1	

CONSEW[®] USA Since 1898

web: www.consew.com