



MODEL
7360RATCWL (E)

PARTS & INSTRUCTION MANUAL

CONTENTS

Instruction manual.....	1-13
Parts catalogue.....	19-34
Arm and bed mechanism.....	19-20
Arm shaft, vertical shaft and thread take-up mechanism.....	21-22
Feeding, feed lifting and rotating hook mechanism.....	23-24
Stitch length regulating mechanism.....	25-26
Presser foot mechanism.....	27-28
Knife actuating mechanism.....	29-30
Reverse sewing and detector mechanism.....	31
Wiper mechanism.....	32
Oil pump mechanism.....	33
Oil reservoir and accessories.....	34

Before putting a new machine into operation, remove the plugs (A) on the top of the arm and replenish the oil supply. Lift the presser foot and run the machine at a low speed of 2000 spm to check that the oil is being distributed correctly by inspecting the window on the oil reservoir. When lubrication is normal, keep the machine running at this speed for 30 minutes, and then increase the running speed gradually. After a month of running, the machine can be run at maximum speed assuming normal working conditions.

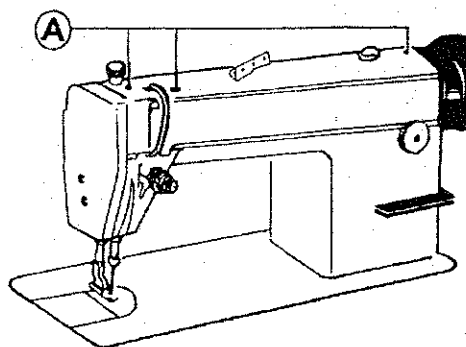

Fig. 1

FILLING THE OIL RESERVOIR

The amount of oil in the reservoir is controlled through the reference marks A and B shown in Fig 2. A indicates the maximum oil level, the mark B is the minimum oil level. If the oil level is below the mark B refill the oil reservoir.

When filling the reservoir, loosen the oil draining screw (c), drain off the remaining oil reservoir completely, clean the reservoir and re-tighten the oil draining screw (c) and fill the oil reservoir with fresh sewing machine oil.

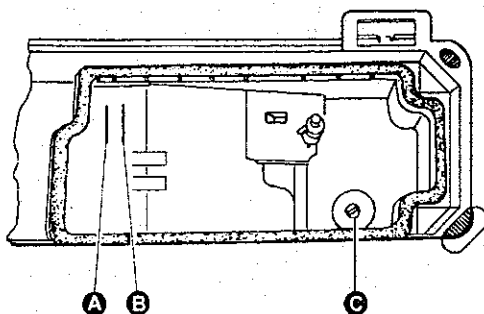

Fig. 2

REGULATING OIL DISTRIBUTION ON THE ROTATING HOOK

Adjust the amount of oil used to lubricate the rotating hook by turning the oil flow adjusting screw (A). Turn the screw (A) clockwise (in the direction of the + sign) to increase the oil flow; turn it counter-clockwise (in the direction of the - sign) to decrease the oil flow.

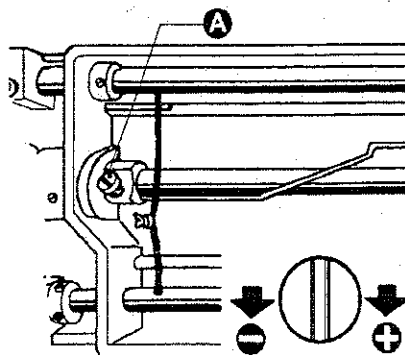

Fig. 3

OIL PUMP ADJUSTMENT

During everyday operation, adjusting the oil pump is not usually necessary. If the oil level doesn't fluctuate in the oil reservoir window when the machine runs at a low speed, close the clearance on the oil bypass hole.

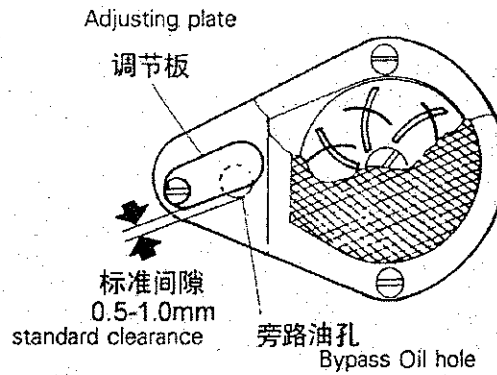

Fig. 4

NEEDLE INSTALLATION

Turn the balance wheel to lift the needle bar to the upper end of its stroke. Loosen the needle clamp screw while keeping the long groove of the needle facing left; insert the needle shank up to the bottom of the needle socket, then tighten the needle clamp screw.

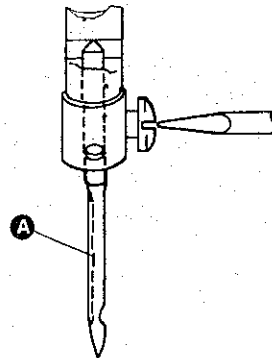

Fig. 5

CONNECTING THE CLUTCH LEVER TO THE PEDAL

The optimum tilt angle of the pedal is approximately 15 degrees.

Adjust the clutch so that the clutch lever (c) aligns with the draw bar (B) as shown

in Fig. 6. The machine pulley should rotate counter clockwise when viewed from the outside of it. The rotating direction of motor pulley can be reversed by turning the plug of the motor 180 degrees.

Adjust the tension of O-Belt (F) by moving the motor up and down; the proper tension on the O-belt is a slack of 10-20 mm when the belt is depressed at the center of the belt.

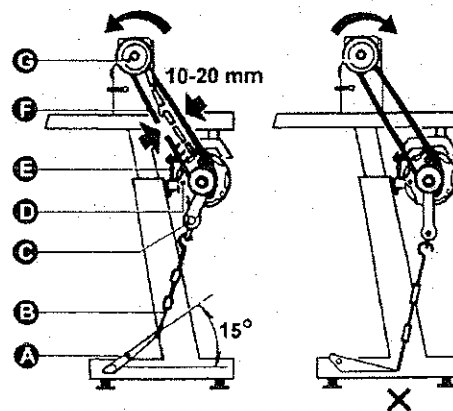

Fig. 6

BELT COVER INSTALLATION

Install the belt cover for the sake of safety. Install belt cover (C) to arm with screw (A) and screw (B), and install belt cover (E) onto table with screw (D).

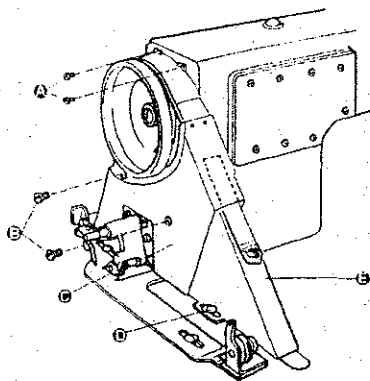

Fig. 7

ADJUSTING THE TIMING OF THE TENSION DISCS

Within the presser foot lift range, the timing of the tension discs can be adjusted as follows:

Remove the rubber plug from the back of the arm and loosen the screw (A) of the knee lift lever (left).

Move the tension releasing cam (D) to the left for earlier opening or to the right for later opening.

It will facilitate the adjustment if a block is put under the presser foot lift.

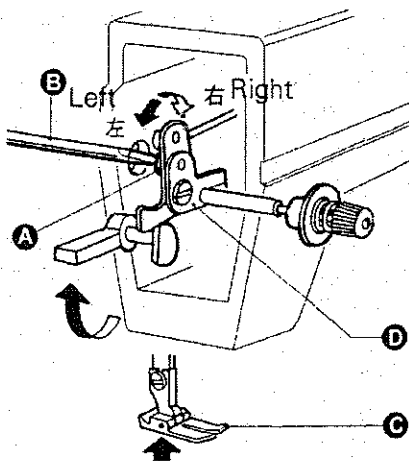

Fig. 8

THREADING

To thread the needle, raise the needle bar to the upper end of its stroke. Lead the thread from the spool and follow the progression as shown in Fig. 9. To draw the bobbin thread, hold the end of the needle thread and turn the balance wheel to lower the needle bar and then lift it to its highest position. Pull the ends of needle thread and bobbin thread toward the front and under the presser foot.

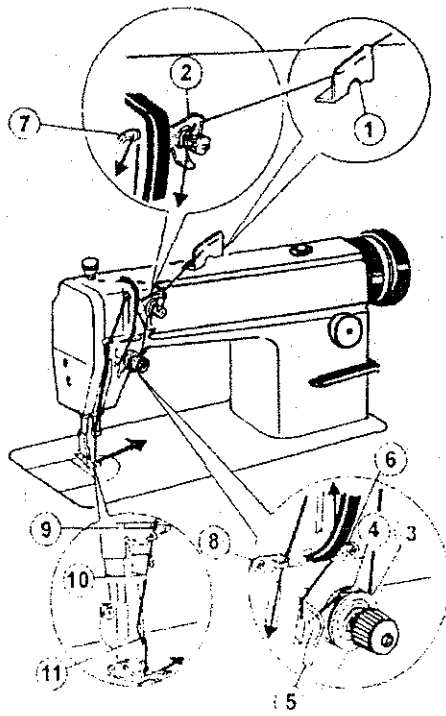

Fig. 9

BOBBIN WINDER INSTALLATION AND ADJUSTMENT

The bobbin winder pulley should align with the V belt and there should be some clearance between them. When the bobbin winder stop latch lever is depressed, the V belt should be in contact with the bobbin winder pulley so that the bobbin winder pulley can be driven by the V belt. The thread on the bobbin should be uniform and tight. If not, turn the tension stud nut (A) on the bobbin winder tension bracket to adjust the tension. First, loosen the set screw (B) on the bobbin winder tension bracket and move the bracket (C) either left or right as needed. For instance, if the thread is wound as illustrated by figure (b), move the bracket left. If it is wound as in figure (c) move it right. After adjusting the tension make sure to tighten set screw (B). Don not overfill the bobbin, figure (d). For best results, fill to about 80% capacity. This can be adjusted by using screw (E).

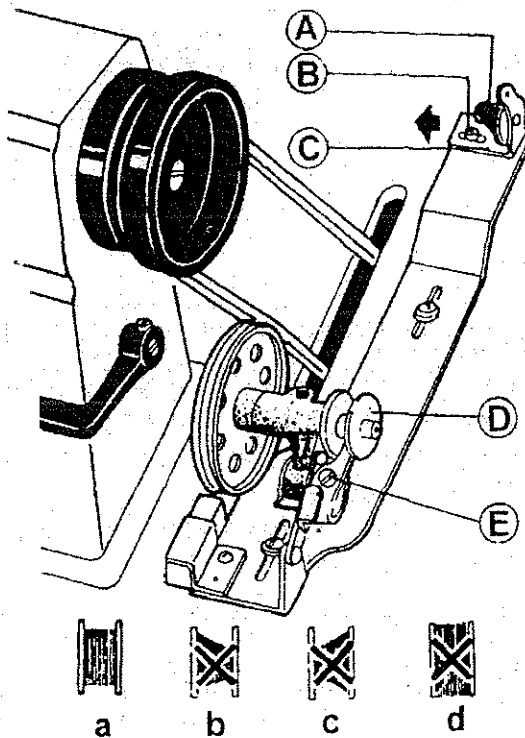

Fig. 10

ADJUSTING THE PRESSURE ON THE PRESSER FOOT

Adjusting the pressure on the presser foot is dependent upon the thickness of the material being sewn. First, loosen lock nut (A). For heavy materials turn the pressure regulating thumb screw in the direction indicated in Fig. 11 (a) to increase the pressure. For light materials turn the thumb screw in the opposite direction as shown in Fig. 11 (b) to decrease the pressure. Once the appropriate pressure has been set tighten lock nut (A).

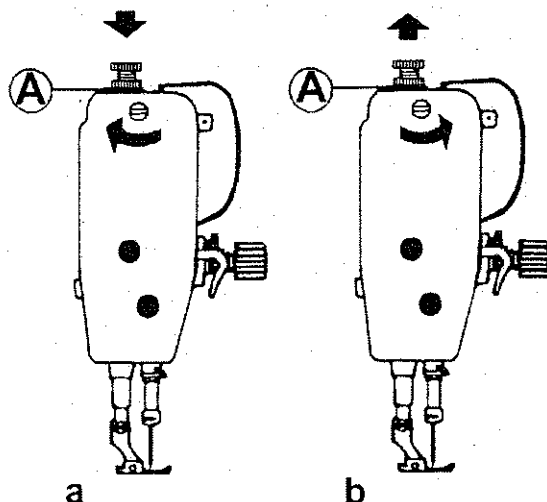

Fig. 11

THREAD TENSION ADJUSTMENT

Thread tension should be determined in tandem with the stitch obtained by adjusting the tension on the bobbin thread and the needle thread Fig. 12. The tension of the bobbin thread should be adjusted by turning the tension spring regulating screw on the bobbin case. Once it is adjusted, insert the bobbin into the bobbin case and hold the end of the thread from the case and let it hang. If the bobbin rotates slowly downward the tension is correct. The tension on the needle thread is adjusted by turning the thumb nut.

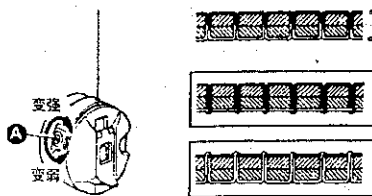

Fig. 12

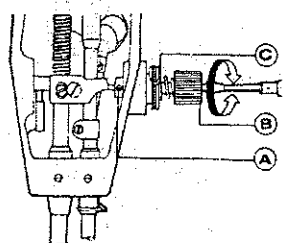
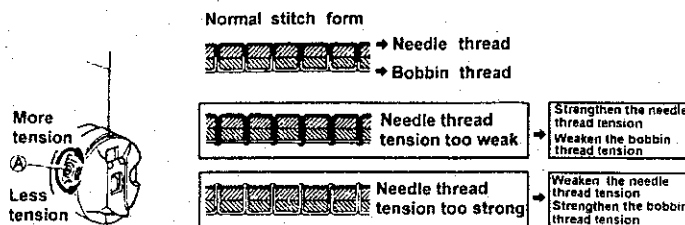

Fig. 13

13

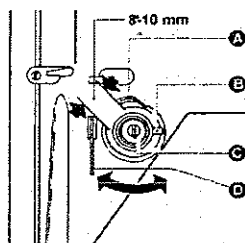

Fig. 14

The stroke of the thread take-up spring runs from 8mm to 10mm. When sewing very thin fabrics, reduce the thread take-up spring tension and increase the thread take-up spring stroke. Conversely increase the thread take-up spring tension and reduce the thread take-up stroke when sewing very thick fabrics.

To adjust the thread take-up spring tension: (Fig. 13), first loosen the set screw (A) then turn the tension stud (B) counter clockwise to decrease the tension of the thread take-up spring (C) to zero. then turn the tension stud (B) clockwise till the spring (C) comes to the notch of the tension regulating bushing, and again turn the tension stud (B) halfway back (counter clockwise), After the adjustment, tighten the set screw (A).

Adjusting the thread take-up spring stroke: (Fig. 14) loosen the set screw (B) turn the stud (C) clockwise to increase the stroke or turn stud (C) counter clockwise to decrease the stroke. After making the adjustment, tighten set screw (B).

SYNCHRONIZATION OF THE NEEDLE WITH THE ROTATING HOOK

When the needle bar is raised from its lowest position the gap should equal that illustrated by (A) in Fig. 15. The hook point (D, Fig. 16) of the bobbin should align with the center line of the needle and be 1- 1.5 mm above upper end of the needle eye (Fig 15).

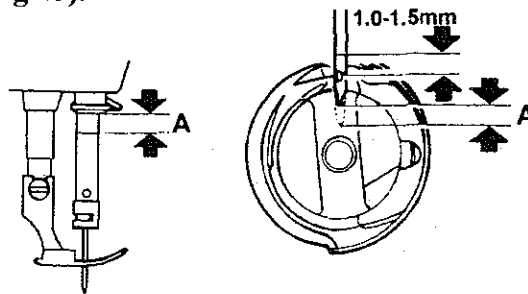

Fig. 15

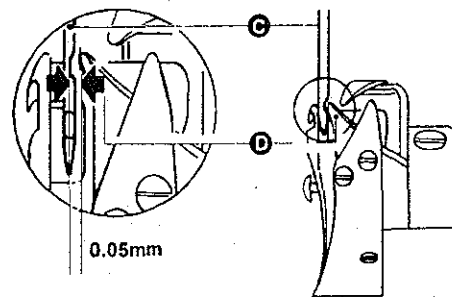

Fig. 16

The clearance between the bottom of the needle notch and the hook point should be approximately 0.05 mm (Fig. 16).

ADJUSTING STITCH LENGTH AND REVERSE FEEDING

The stitch length can be adjusted by turning dial (A). The figures on the face (B) of the dial show the stitch length in mm. The reverse feed lever must be depressed while adjusting the stitch length. Reverse feeding starts when the reverse feed lever (c) is depressed, the machine will feed forward again when the reverse feed lever is released.

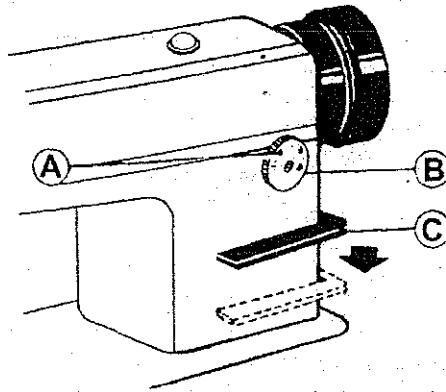

Fig. 17

ADJUSTING THE POSITION OF THE FEED DOG AND NEEDLE

Turn the balance wheel to lower the Feed Dog (A). When the top of the feed dog is flush with the Throat Plate Surface (B), the Needle Point (C) should be 3mm below the surface of the throat plate. The adjustment should be made by adjusting the position of the feed cam and feed lift cam (Fig. 19).

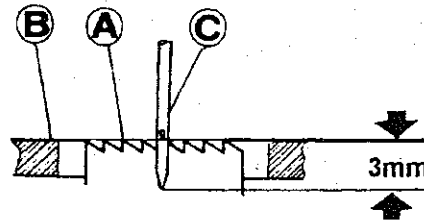

Fig. 18

Standard position is shown in Fig. 19. For the third screw (A) of feed cam and the second screw (B) of feed lift cam to Arm Shaft Oil Hole (C) is set to the direction of the balance wheel turning.

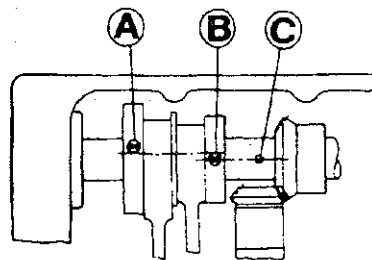

Fig. 19

STITCH LENGTH ADJUSTMENT

Loosen Screw (A) to adjust Stitch Length Adjusting Cam (B). Turn it to the right to narrow the stitch length for forward stitches, and widen it for reverse; turn it left to widen the stitch length for forward stitches, and narrow it for reverse.

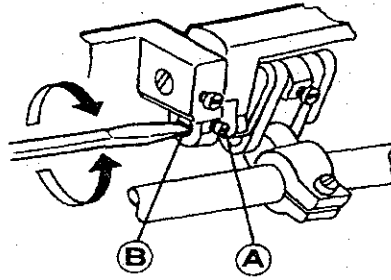

Fig. 20

FEED DOG HORIZONTAL ADJUSTMENT

Lift the front of the feed dog to prevent the fabric from puckering. Lower the front of the feed dog to prevent the fabric from tearing or the bobbin thread breaking.

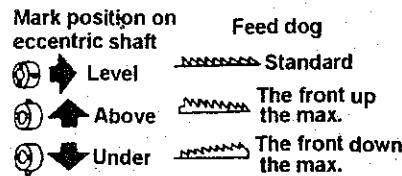

Fig. 21

THREAD CUTTING MECHANISM

The thread cutting mechanism adapts the hook shaft cam driving for thread cutting. If thread cutting electromagnet works, and after it finishes trimming the thread, reset thread cutting cam crank at once, otherwise this may cause the movable knife and needle to collide and damage them.

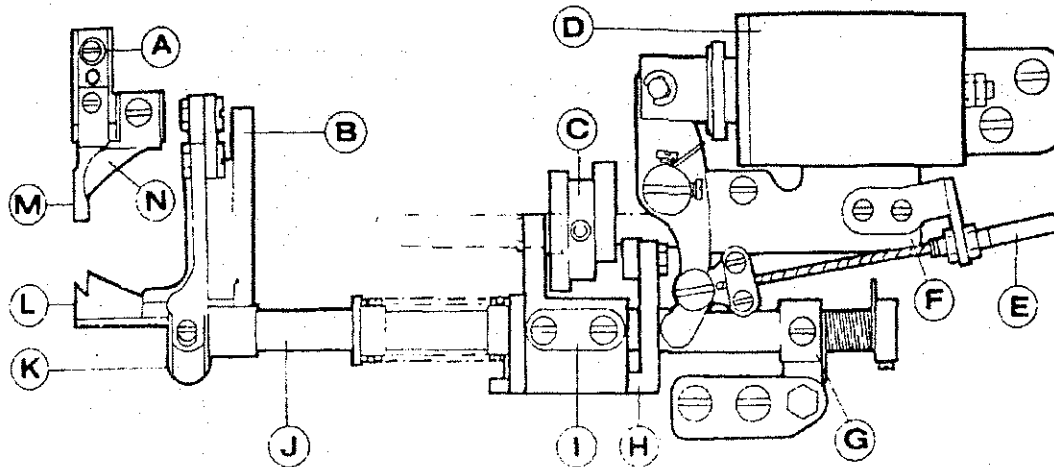

Fig. 22

KEY FOR Fig. 22

- | | |
|------------------------------|-----------------------------------|
| A - fixed knife support asm. | B - knife support asm. (left) |
| C - thread cutting cam. | D - thread cutting electromagnet. |
| E - soft thread. | F - electromagnet asm. |
| G - stopper. | H, I - thread cutting cam crank. |
| J - cutter driving shaft. | K - cutter driving crank. |
| L - knife (left). | M - fixed knife. |
| N - thread retainer. | |

KNIFE SUPPORT ASM (left)

Insert the left knife support assembly (B) into Hook Shaft Bushing (C) as the figure shows and then tighten screw (A).

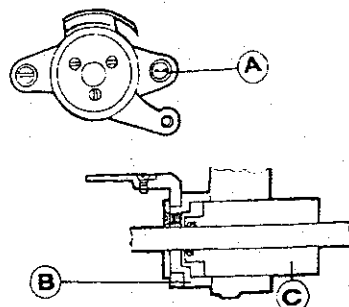

Fig. 23

FIXED KNIFE SUPPORT ASSEMBLY

Remove the hook positioner and then set it with screw (A) shown in Fig 24 (B)-fixed knife support assembly.

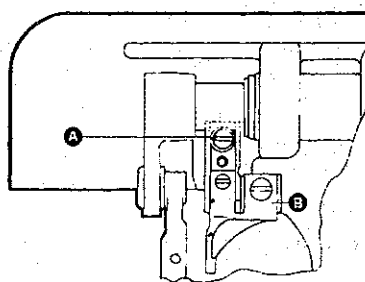

Fig. 24

POSITION OF THE FIXED KNIFE AND LEFT KNIFE POINT

(1) The standard position is shown in figure 24. If the size is larger than the standard, the knife will either cut the 3 threads or draw the thread out of the needle eye; if smaller, it will cause damage, so be sure to avoid that. If any of the above mentioned situations occur, adjust by setting the fixed knife support or the fixed knife (B).

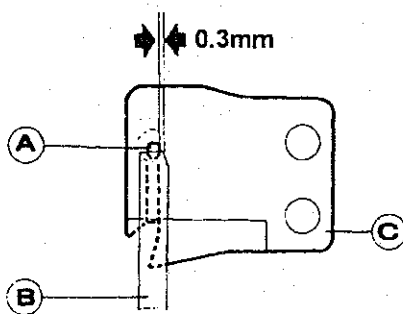

Fig. 25

A-the blade C-the knife (left)

CONNECTING THE KNIFE SUPPORT AND CUTTER DRIVING CRANK

Connect them as figure 26 shows and notice the position of Cutter Link Lever (A).

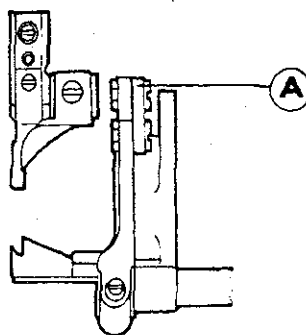

Fig. 26

POSITIONING THE CUTTER DRIVING SHAFT

The Standard position is shown in figure 27. When assembled, the Cutter Driving Shaft (G) should first be put in Cutter Driving Crank (A). Set Thread Cutting Cam Crank 1 (D) on the cutter driving shaft by referring to the standard position. Set Stopper (F), make sure that there is no clearance between parts around the cutter driving shaft, and rotate evenly.

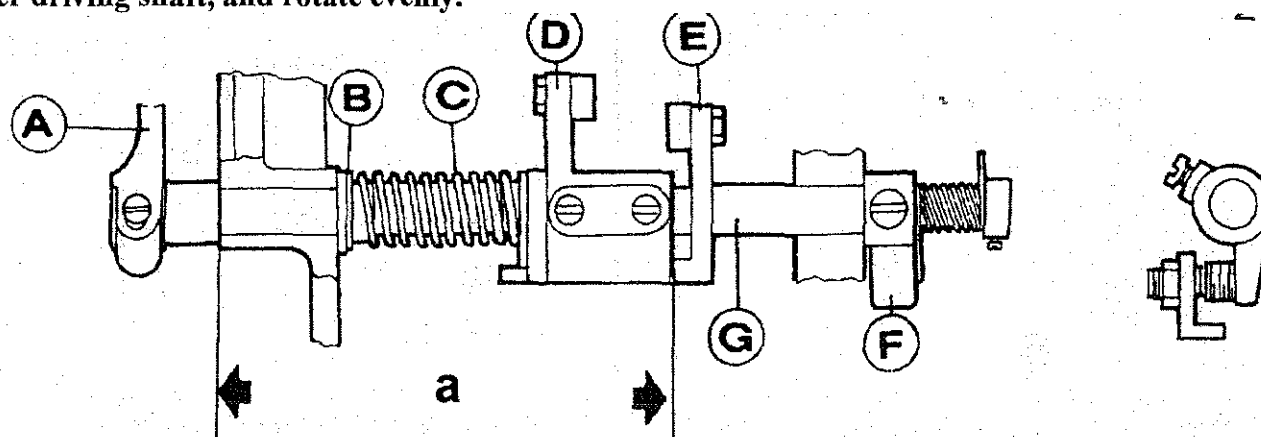

Fig. 27 B-spring end cover C-spring E-thread cutting cam crank 2

THE ELECTROMAGNET CORE STROKE

The standard stroke of the electromagnet core is 6mm. The stroke can be adjusted with Positioning screw (A).

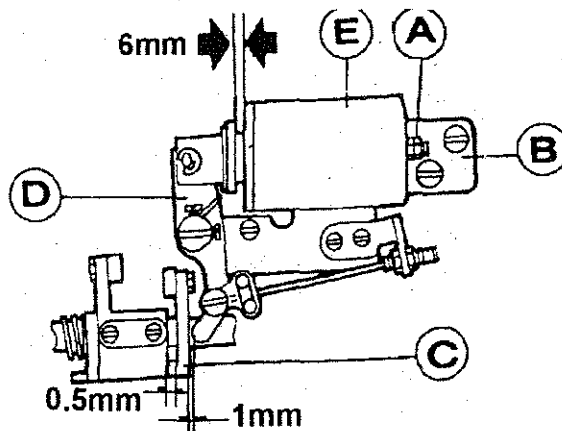

Fig. 28

- B-thread cutting electromagnet holder
- C-thread cutting cam crank 2
- D-driving bar
- E-thread cutting electromagnet

The installation parameters are shown in Fig. 28.

INSTALLING THE THREAD CUTTING CAM

Align balance wheel machine arm No. 2 Positioning Mark (A) with Positioning Mark (B) on the machine arm as shown in Fig. 29.

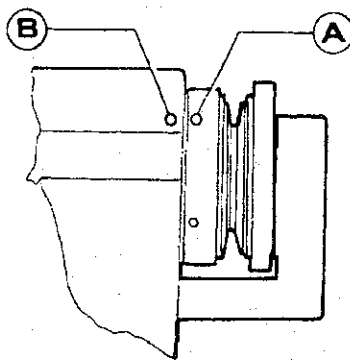

Fig. 29

As the thread cutting electromagnet runs, the Thread Cutting Cam (A) rotates in the normal direction. Fix the cam when Cam (A) is engaged with Roller (B).

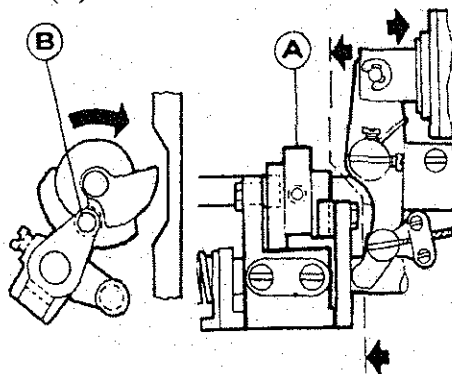

Fig. 30

To stop operating the electromagnet, reset Cam Driving Crank (A), Cam (B) is separated from engaging with the roller, the standard clearance is 0.5-1 mm.

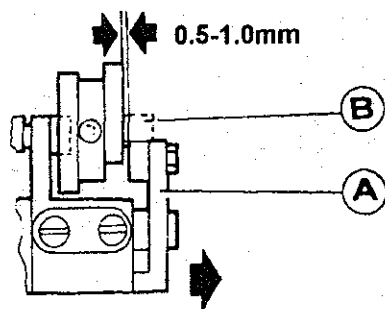

Fig. 31

Note: figure 32 shows the standard position of Cam Driving Crank (D) before operation.

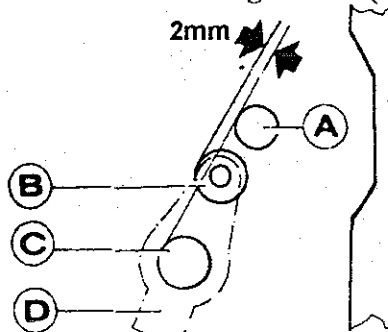

Fig. 32

Key: A-hook shaft B-roller C-cutter driving shaft

It may change the positions mentioned above to remove the stopper, then adjust with Screw (A), and readjust following the progression from Fig. 29-31.

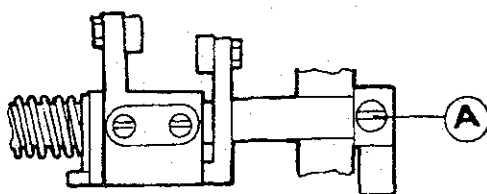

Fig. 33

ADJUSTING KNIFE CUTTING DEPTH

Figure 34 shows the standard positions of left knife and the fixed knife.

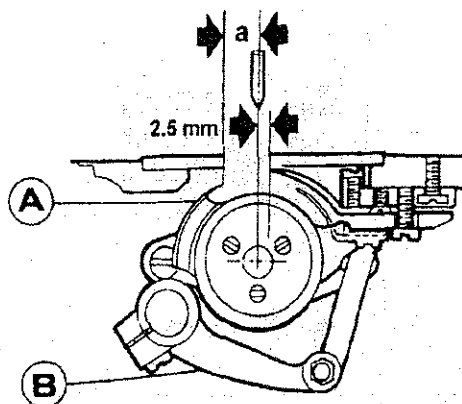

Fig. 34

Key: A-knife (right) B-cutter driving shaft

Adjusting the knife cutting depth: When the electromagnet is working, run the machine, the left knife (A) will follow the motion of the thread cutting cam. The maximum degree of cutting depth is 1.5-2.0mm (B) for the fixed knife. Adjust the cutter driving crank if necessary.

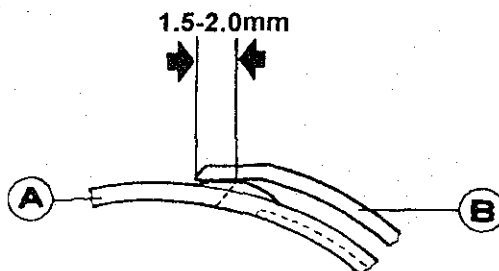

Fig. 35

ADJUSTING THE CUTTING PRESSURE

Figure 36 shows the standard position that the Left Knife (A) begins to touch the Fixed Knife (B).

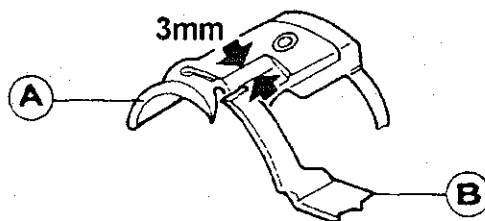

Fig. 36

(2) When cutting heavier thread, increase the cutting pressure. To adjust the cutting pressure, loosen Set Nut (A), and adjust Screw (B).

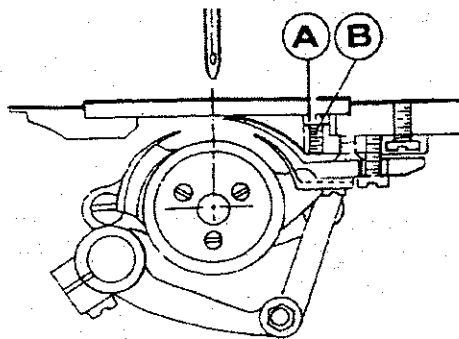

Fig. 37

ADJUSTING THE NEEDLE THREAD TENSION

There should be a clearance of 1 mm between the two discs while the thread cutting electromagnet (A) is working. To make an adjustment, loosen Nut (B) and move soft thread (C).

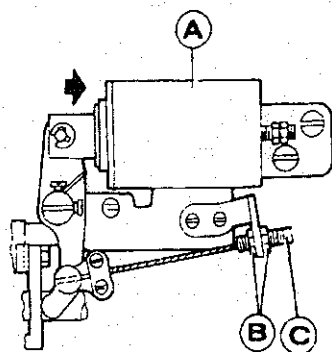

Fig. 38

Note: If the clearance is too narrow, the thread end left after cutting is too short and may be pulled away from the needle eye; otherwise the tension will be slack and will effect the needle thread tension.

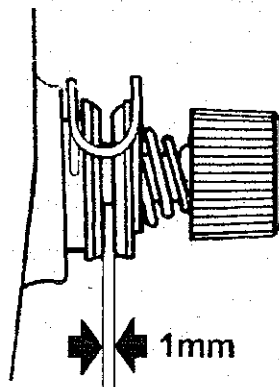

Fig. 39

THREAD ENDS ADJUSTMENT

To get the needle thread ends to the proper length, adjust Nut (A). Turn right to shorten. Turn left to lengthen.

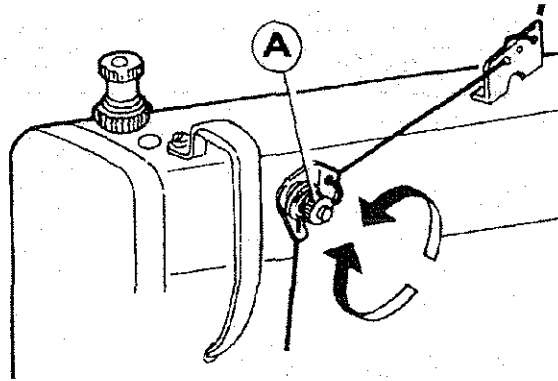

Fig. 40

INSTALLING REVERSE STITCH ELECTROMAGNET

Adjust the position of Electromagnet (A) properly to guarantee the flexible connection of the magnet to the link lever and the convenient operation of Reverse Stitch Bar (B), then set with a screw.

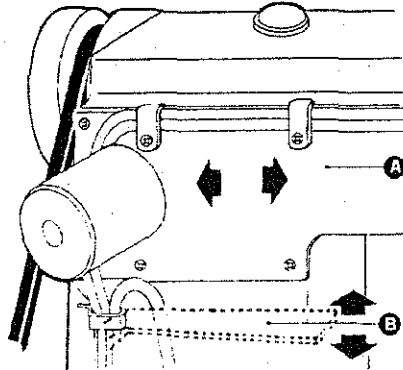

Fig. 41

REVERSE SWITCH

The figure shows the normal position. To reverse stitch, simply slide the switch as indicated in Fig. 42. To resume normal sewing, slide the switch back to the original position.

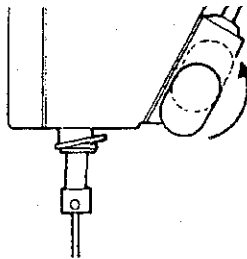

Fig. 42

THREAD RETAINING DEVICE

Thread Retainer Height

The standard height is 2 mm from the needle point when the needle is at its highest position.

To adjust Thread Retainer (B), loosen screw (A).

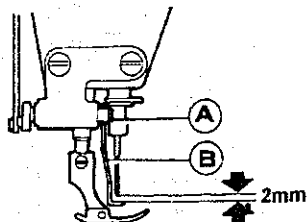

Fig. 43

When the magnet is electromagnetically engaged, the standard distance between the thread retainer and the center of the needle should be 0-2 mm.

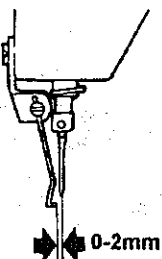

Fig. 44

To adjust its position, loosen Screw (C) and Screw (B) and then adjust the position of Electromagnet Assembly (A).

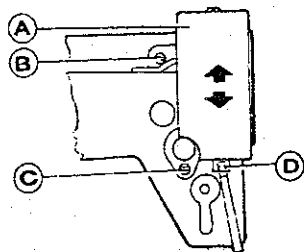
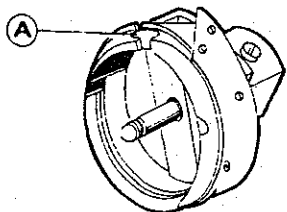
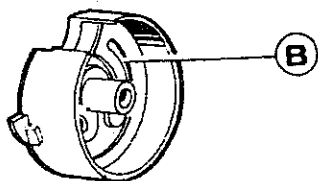

Fig. 45

HOOK BOBBIN CASE AND BOBBIN



There is a thread groove (A) in the special hook for thread cutting sewing machine.



2. The bobbin case used in the machine should be equipped with a spring (B) in the bottom, which prevents the bobbin from running when it is empty.

PARTS CATALOGUE

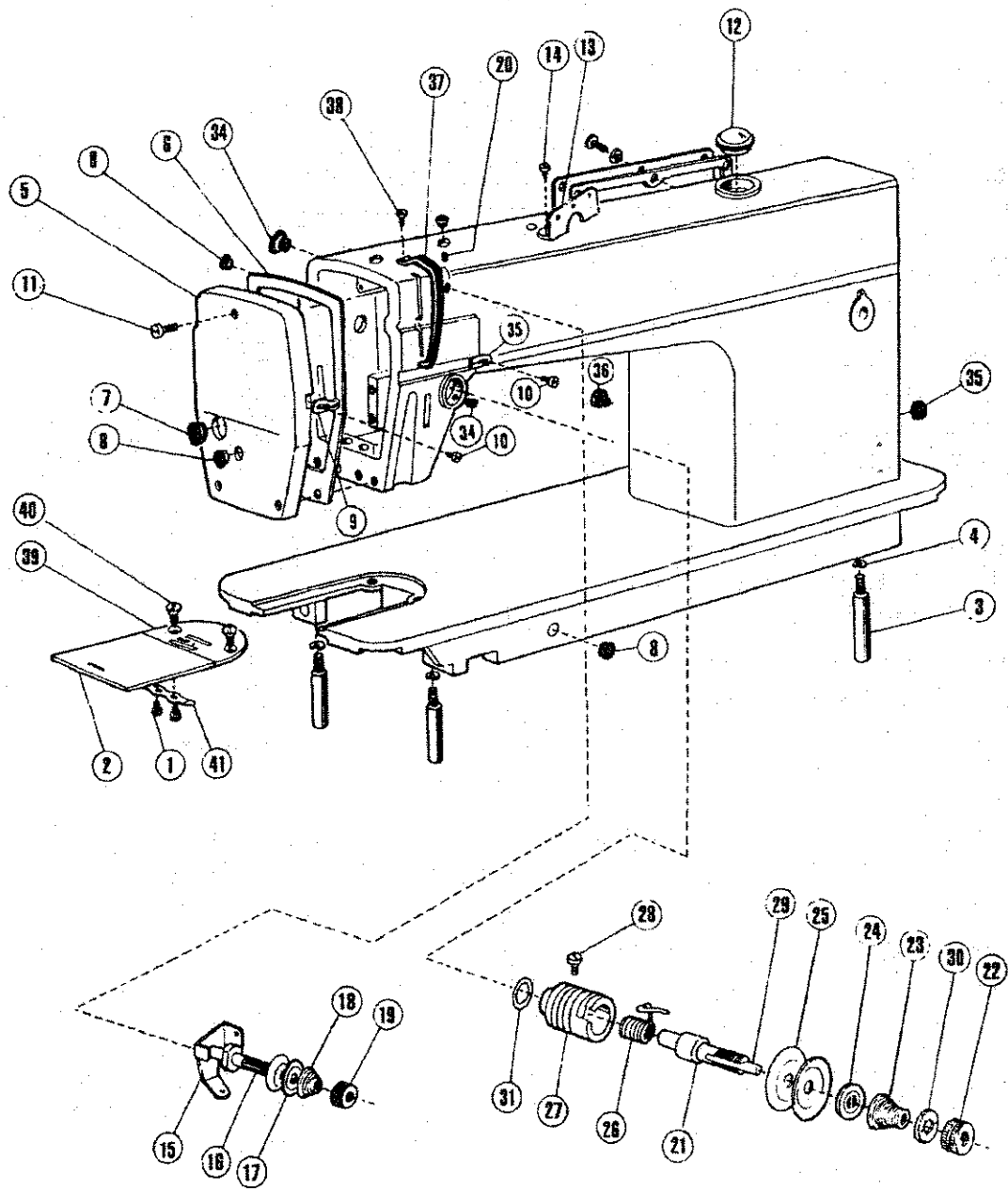

ARM AND BED MECHANISM

No.	Part No.	Description	Description
1	22T1 -021G3	推板簧螺钉	Screw
2	22T1 -021G1	推板	Slide plate
3	48T1 -005	底板撑杆	Leg
4	GB93 -76	垫圈 6	Spring washer 6
5	124T1 -002B1	面板	Face plate
6	124T1 -002B2	面板垫片	Face plate gasket
7	22T1 -003C3	橡皮塞	Rubber plug
8	22T1 -003C4	橡皮塞	Rubber plug
9	22T1 -003C5	面板线勾	Thread guide on face plate
	78T1 -004C1	面板线勾	Thread guide on face plate
10	22T1 -003C6	线勾螺钉	Screw
11	22T1 -004	面板螺钉	Screw
12	22T1 -008H	油窗组件	Oil check window
13	36T2 -004	三孔线勾	Three - hole thread guide
14	36T2 -005	三孔线勾螺钉	Screw
15	36T2 -006D1	小夹线过线板	Pretension thread guide
16	36T2 -006D2	小夹线螺钉	Thread tension stud
17	22T1 -009E3	小夹线板	Thread tension disc
18	36T2 -006D3	小夹线弹簧	Tension spring for pretension
19	36T2 -006D4	小夹线螺母	Thread tension nut
20	22T1 -011	小夹线固定螺钉	Set screw
21	22T1 -012F1	夹线螺钉	Thread tension stud
22	22T1 -012F2	夹线螺母	Thread tension nut
23	22T1 -012F3	夹线弹簧	Thread tension spring
	48T1 -003A1	夹线弹簧	Thread tension spring
24	22T1 -012F4	松线板	Thread tension releasing disc
25	22T1 -012F5	夹线板	Thread tension disc
26	22T1 -012F6	挑线簧	Thread take -up spring
	48T1 -003A2	挑线簧	Thread take -up spring
27	22T1 -012F7	夹线调节座	Thread tension regulator bushing
28	22T1 -012F8	夹线调节座螺钉	Screw
29	22T1 -012F9	松线钉	Thread tension releasing pin
30	22T1 -012F10	夹线螺母止动板	Stop disc
31	22T1 -012F11	O 型圈	O - type ring
32	22T1 -013	夹线调节座固定螺钉	Set screw
33	22T1 -014	线勾	Thread guide
	78T1 -005	线勾	Thread guide
34	22T1 -015	橡皮塞	Rubber plug
35	22T1 -016	橡皮塞	Rubber plug
37	36T2 -007	挑线杆护罩	Thread take -up lever guard
	78T2 -002	挑线杆护罩	Thread take -up lever guard
38	22T2 -004	挑线杆护罩螺钉	Screw
39	36T2 -008	针板(B1.8)	Needle plate
	48T1 -004	针板	Needle plate
40	22T1 -020	针板螺钉	Screw
41	22T1 -012G2	推板簧	Slide plate spring

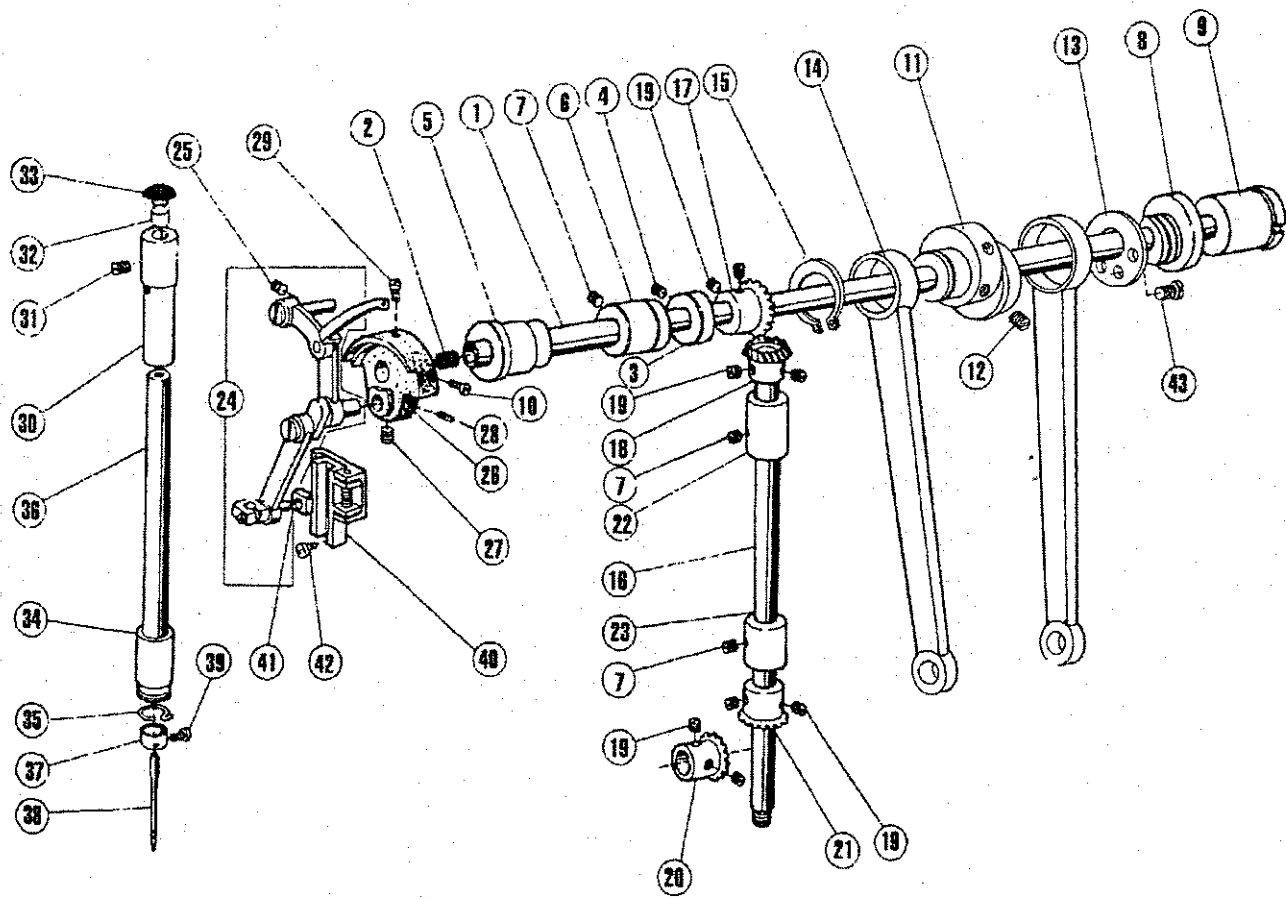

ARM SHAFT, VERTICAL SHAFT AND THREAD TAKE-UP MECHANISM

No.	Part No.	Description
1	108T3-001A1	上轴 Arm shaft
2	22T3-001A2	上轴橡皮塞 Rubber plug
3	22T3-002B1	上轴紧圈 Collar for arm shaft
4	22T2-005B3	上轴紧圈螺钉 Screw
5	22T3-003	上轴轴套(左) Arm shaft bushing (left)
6	22T3-004	上轴轴套(中) Arm shaft bushing (middle)
7	22T2-002	轴套螺钉 Screw
8	165310001	上轴轴套(右) Arm shaft bushing (right)
9	124T3-003C2	上轴轴套(右)油封 Oil seal
10	22T2-006	针杆曲柄螺钉 Screw
11	36T3-003	凸轮 Eccentric wheel
	114T3-001	凸轮 Eccentric wheel
12	22T1-013	凸轮螺钉 Eccentric wheel screw
13	36T3-004	凸轮挡板 Spacer
14	22T3-009D1c	拾牙连杆 Crank rod for lifting rock shaft
15	36T3-004	送布凸轮挡板 Spacer
16	22T3-010E1	竖轴 Vertical shaft
17	22T3-010E2a1-2	上轴伞齿轮 Bevel gear for arm shaft
18	22T3-010E2a2-2	竖轴伞齿轮(上) Bevel gear for vertical shaft (upper)
19	22T2-005B3	伞齿轮螺钉 Set screw
20	22T3-010E2b1-2	下轴伞齿轮 Bevel gear for hook shaft
21	22T3-010E2b2-2	竖轴伞齿轮(下) Bevel gear for vertical shaft (lower)
22	22T3-011	竖轴轴套(上) Vertical shaft bushing (upper)
23	22T3-011	竖轴轴套(下) Vertical shaft bushing (lower)
	78T3-002	竖轴轴套(下) Vertical shaft bushing (lower)
24	22T2-001A	针杆连杆挑线大组件 Needle bar link asm
	48T2-001A	针杆连杆挑线大组件 Needle bar link asm
	78T2-001A	针杆连杆挑线大组件 Needle bar link asm
25	22T2-002	挑线连杆铰链轴螺钉 Screw
26	22T2-005B1	针杆曲柄 Needle bar crank
	48T2-002B	针杆曲柄 Needle bar crank
27	22T2-005B2	挑线曲柄螺钉 Screw
28	22T2-006	挑线曲柄定位螺钉 Screw
29	22T2-007	针杆曲柄定位螺钉 Set screw
30	22T2-008	针杆轴套(上) Needle bar bushing (upper)
31	22T2-009	针杆轴套(上)螺钉 Screw
32	22T2-010	针杆轴套(上)毡塞 Felt plug
33	22T2-011	针杆轴套(上)橡皮塞 Rubber plug
34	22T2-012C1	针杆轴套(下) Needle bushing (lower)
	124T2-006	针杆轴套(下) Needle bushing (lower)
35	22T2-012C2	针杆轴套(下)过线勾 Thread guide
36	22T2-014	针杆 Needle bar
	78T2-004	针杆 Needle bar
37	22T2-015	针杆过线环 Thread guide for needle bar
	48T2-004	针杆过线环 Thread guide for needle bar
38	DB x1 14#	机针 Needle
	DP x5 18#	机针 Needle
	DB x1 22#	机针 Needle
39	22T2-017	夹针螺钉 Screw
40	36T3-005E	针杆接头滑块导轨组件 Guide rail for slide block
41	22T2-020	针杆接头滑块 Slide block
42	22T2-019	滑块导轨螺钉 Set screw
43	100T6-012	送布凸轮挡板螺钉 Screw

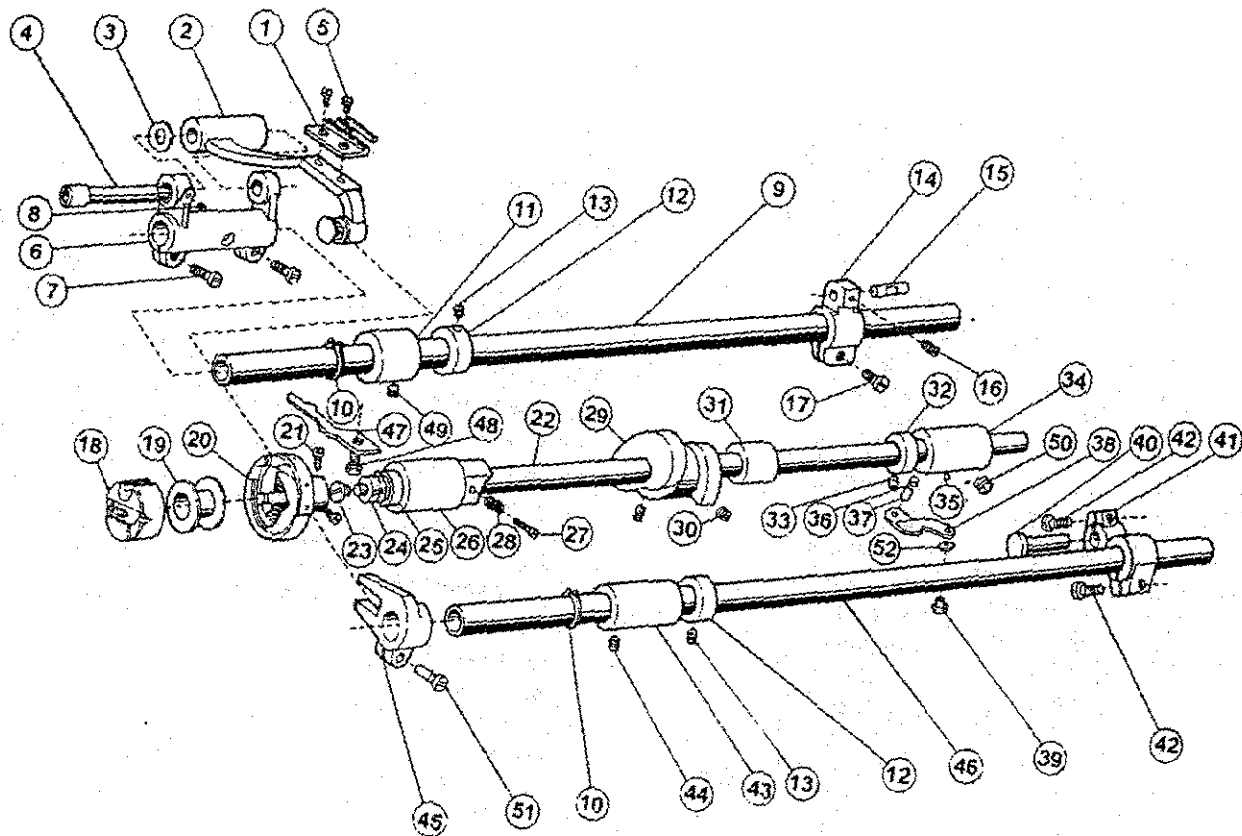

FEEDING, FEED LIFTING AND ROTATING HOOK MECHANISM

No.	Part No.	Description	Description
1	22T6 -001A3	送布牙	Feed dog
2	36T4 -001A1a	牙架小组件	Feed bar
3	22T6 -001A6	牙架垫圈	Washer
4	36T4 -001A2	牙架曲柄偏心轴	Shaft for feed bar
5	22T6 -001A4	送布牙螺钉	Screw
6	22T6 -001A1a	牙架曲柄	Feed rock shaft crank
7	22T6 -001A1b	牙架曲柄螺钉	Screw
8	22T2 -019	牙架曲柄轴螺钉	Screw
9	36T4 -002	送布轴	Feed rock shaft
10	GB894 -76	轴用弹性挡圈	C - type stop ring
11	22T6 -004	送布轴轴套	Bushing for feed rock shaft
12	22T6 -005B1	紧圈	Collar for feed rock shaft
13	22T3 -002B2	紧圈螺钉	Screw
14	36T4 -003	送布轴曲柄(右)	Feed rock shaft crank (right)
	114T4 -001	送布轴曲柄(右)	Feed rock shaft crank (right)
15	36T4 -004H01	曲柄连杆短销	Pin
16	36T5 -008E5	曲柄连杆短销螺钉	Screw
17	22T6 -008D3	送布轴曲柄(右)螺钉	Screw
18	36T4 -005B	梭芯套组件	Bobbin case complete
	78T4 -004F	梭芯套组件	Bobbin case complete
19	36T4 -006	梭芯	Bobbin
	78T4 -005	梭芯	Bobbin
20	36T4 -007C	旋梭组件	Rotating hook complete
		旋梭组件	Rotating hook complete
21	36T4 -007C4	旋梭螺钉	Screw
22	36T4 -008D1	下轴	Hook shaft
	120T4 -001	下轴	Hook shaft
23	22T4 -001A1a1	下轴滤油塞螺钉	Filter screw
24	22T4 -001A1a2	下轴滤油塞	Filter
25	36T4 -009G	下轴油封	Oil seal
26	36T4 -010	下轴轴套(左)	Hook shaft bushing(left)
27	22T4 -005	油量调节螺钉	Oil adjusting screw
28	22T4 -006	油量调节弹簧	Coil spring
29	36T4 -011E1	切线凸轮	Thread cutting cam
30	36T4 -011E2	切线凸轮螺钉	Screw
31	36T4 -012	下轴轴套(中)	Hook shaft bushing(middle)
32	22T4 -002B1	下轴紧圈	Collar for hook shaft
33	22T2 -009	下轴紧圈螺钉	Screw
34	36T4 -014F1	下轴轴套(右)	Hook shaft bushing(right)
35	22T4 -007C2	下轴轴套油管	Oil pipe for hook shaft bushing
36	36T4 -015	柱塞	Plunger
37	36T4 -016	柱塞弹簧	Plunger spring
38	22T4 -010	挡板	Guide plate
	78T4 -006	挡板	Guide plate
39	22T8 -009	挡板螺钉	Screw
40	22T6 -007	抬牙轴曲柄铰链轴	Hinge pin
41	36T4 -017	抬牙曲柄(右)	Feed lifting rock shaft crank(right)
42	J0.0.71	抬牙曲柄螺钉	Screw
43	22T6 -012	抬牙轴套(左)	Bushing for feed lifting shaft(left)
44	22T2 -002	抬牙轴套螺钉	Screw
45	36T4 -018H1D1	抬牙叉	Feed lifting fork
46	36T4 -018H2	抬牙轴	Feed lifting rock shaft
47	22T4 -013	旋梭定位勾	Hook positioner
	48T4 -002	旋梭定位勾	Hook positioner
	78T4 -003	旋梭定位勾	Hook positioner
48	22T4 -015	旋梭定位勾螺钉	Screw
49	22T2 -009	送布轴轴套螺钉	Screw
50	22T1 -013	下轴轴套(右)螺钉	Screw
51	22T6 -008D3	抬牙叉夹紧螺钉	Screw
52	GB93 -76	挡板螺钉弹簧垫圈	Washer

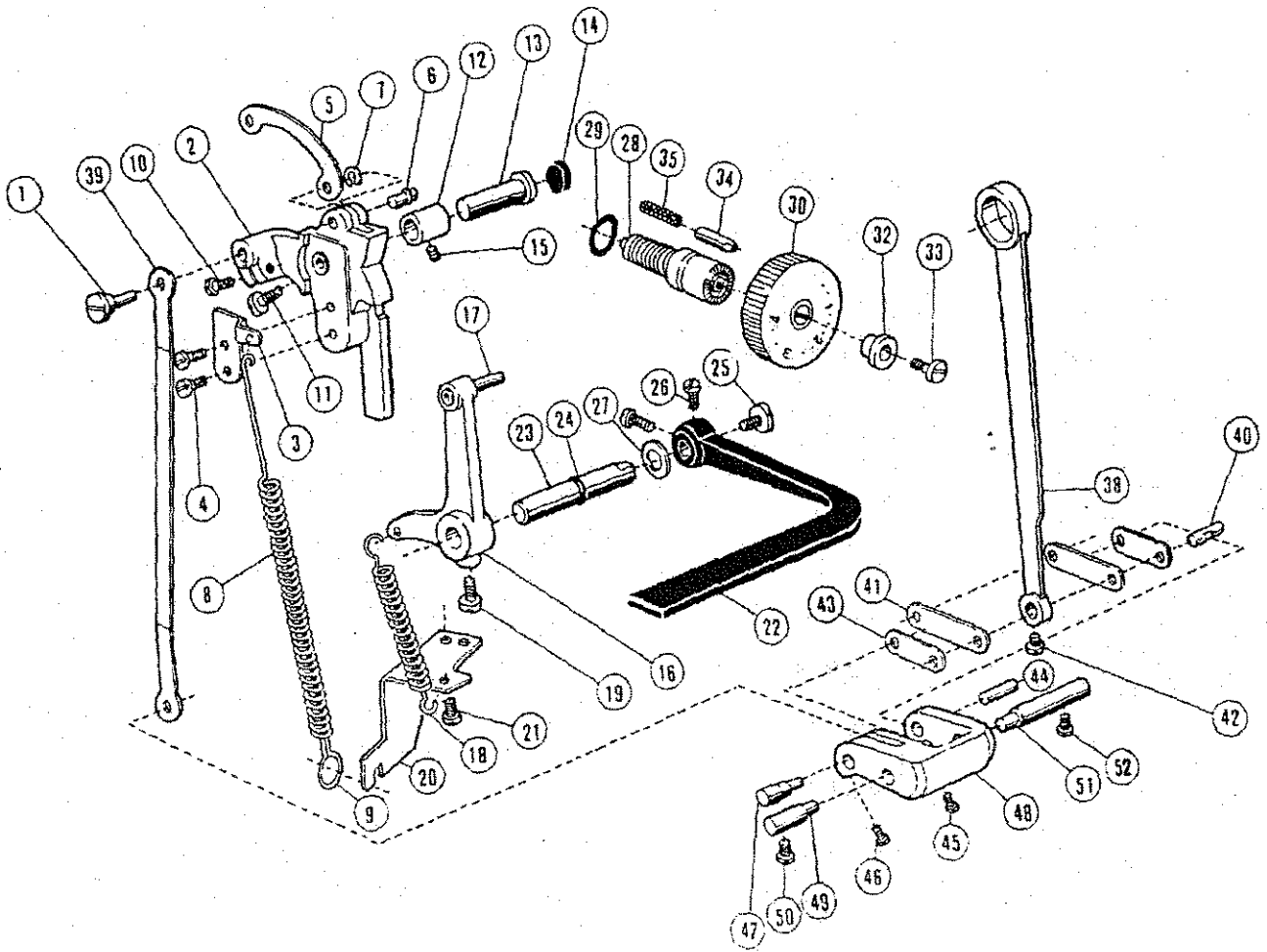

STITCH LENGTH REGULATING MECHANISM

No.	Part No.	Description	Description
1	36T5 -001	针距调节连杆销钉	Set pin
2	36T5 -002A1	针距座	Feed regulator
	114T5 -001	针距座	Feed regulator
3	36T5 -002A2	拉簧勾	Spring retainer
4	22T2 -019	拉簧勾螺钉	Screw
5	36T5 -002A3	倒缝连杆	Link
6	36T5 -002A4	针距座销	Pin
7	GB896 -75	开口挡圈	Split retaining ring
8	36T5 -002A5	针距座拉簧	Coil spring
9	36T5 -002A6	针距座拉簧调节勾	Spring holder
10	22T6 -008D3	针距座长螺钉	Screw
11	22T5 -010D4	针距座短螺钉	Screw
12	22T5 -003	针距座衬套	Bushing for feed regulator
13	22T5 -004	针距座轴	Pin shaft
14	36T5 -003	橡皮塞	Rubber plug
15	22T2 -002	针距座衬套紧固螺钉	Set screw
16	36T5 -004B1	倒缝操纵杆曲柄	Reverse sewing crank
17	36T5 -004B2	操纵杆曲柄轴	Reverse sewing crank shaft
18	36T5 -004B3	操纵杆拉簧	Coil spring
19	22T5 -013	操纵杆曲柄螺钉	Screw
20	36T5 -005	拉簧架	Spring holder
21	22T5 -001A4	拉簧架螺钉	Screw
22	22T5 -010D1	倒缝操纵杆	Reverse sewing lever
23	36T5 -006C1a1	倒缝操纵杆短轴	Shaft for reverse sewing lever
24	GB3452.1 -92	O型密封圈 6.3 ×1.8G	O -type ring
25	22T5 -010D3	倒缝操纵杆吊紧螺钉	Screw
26	22T5 -010D4	倒缝操纵杆螺钉	Screw
27	22T5 -011	倒缝操纵杆垫圈	Washer
28	124T5 -001A2	针距调节螺杆	Screw bar
29	124T5 -001A3	O型橡胶圈	O -type rubber ring
30	124T5 -002B1	针距旋钮	Dial
	124T5 -001A5	针距旋钮	Dial
32	36T5 -007D4	标盘螺钉衬套	Bushing
33	36T5 -007D5	针距盘螺钉	Screw
34	36T5 -012	止动销	Thrust pin
35	22T5 -009	止动销弹簧	Coil spring
38	36T5 -008E2	送布连杆	Feed link
39	36T5 -008E3	针距调节连杆	Stitch length regulating link
40	36T4 -004H02	曲柄连杆长销	Pin
41	36T5 -008E4H02	曲柄长连杆	Link
	114T5 -003	曲柄长连杆	Link
42	36T5 -008E5	送布连杆螺钉	Screw
43	36T5 -008E4H01	曲柄短连杆	Link
44	36T5 -008E6	曲柄短连杆销	pin
45	36T5 -008E7	短连杆销螺钉	Screw
46	36T5 -008E8	连杆偏心轴螺钉	Screw
47	36T5 -008E9	连杆偏心轴	Eccentric shaft
48	36T5 -008E10	针距调节曲柄	Stitch length adjusting crank
49	36T5 -009H02	针距调节曲柄定位销(左)	Set pin(left)
50	22T6 -008D3	左定位销螺钉	Screw
51	36T5 -009H01	针距调节曲柄定位销(右)	Set pin(right)
52	22T6 -008D3	右定位销螺钉	Screw

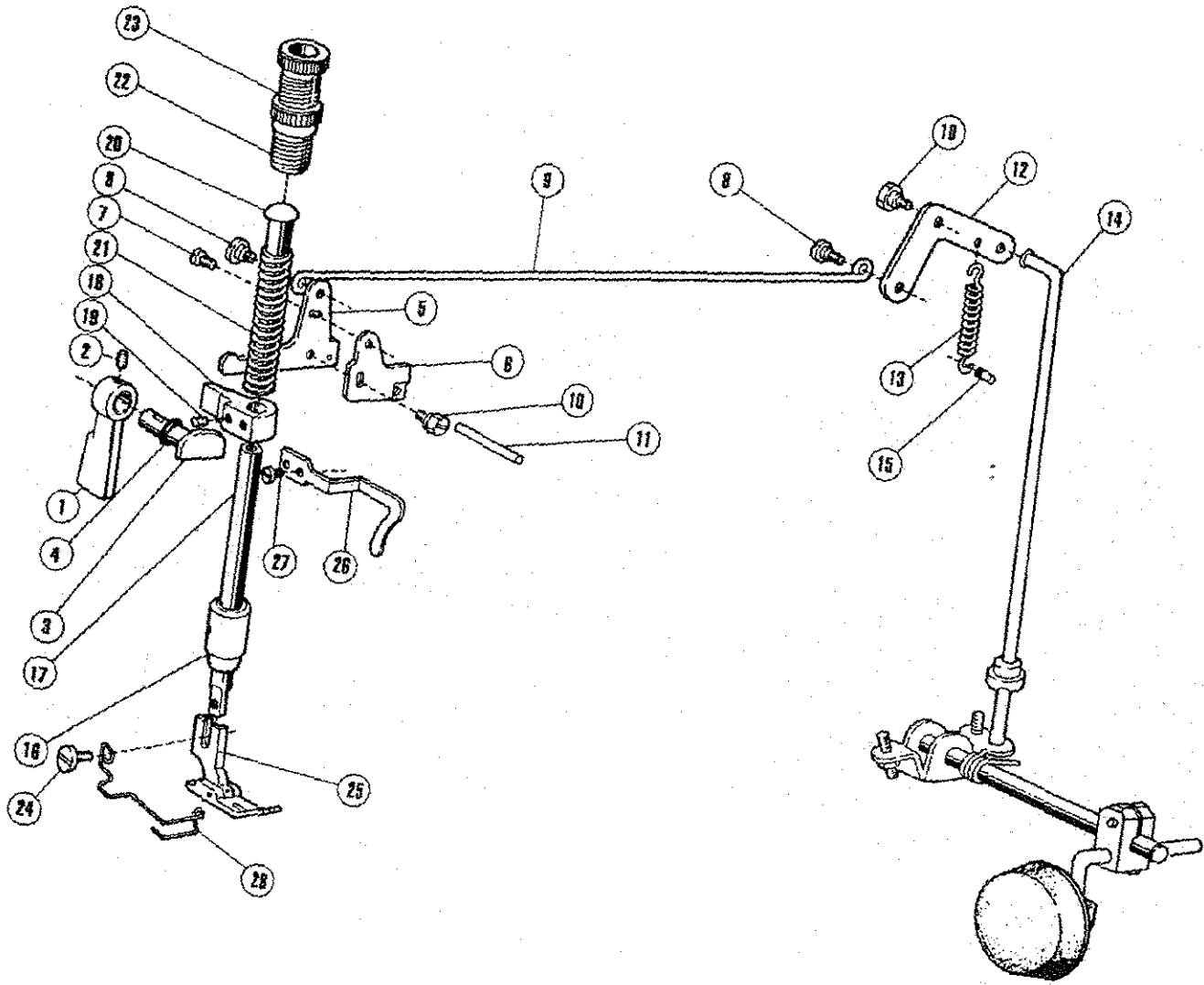

PRESSER FOOT MECHANISM

No.	Part No.	Description
1	57T7-001A1	压脚扳手 Presser bar lifter
2	J0.0.35	压脚扳手螺钉 Screw
3	36T6-002B1	压紧杆提升凸轮 Presser bar lifting cam
4	GB1235-76	压紧杆提升凸轮油封 Oil seal
5	36T6-003C1a1	膝控提升杠杆(左) Knee lifter lever (left)
6	22T7-004B1b	松线凸轮 Tension releasing cam
7	22T7-004B1c	膝控提升杠杆(左)螺钉 Screw
8	22T7-004B2	铰链螺钉 Screw
9	22T7-004B3	膝控提升拉杆 Knee lifter rod
10	22T7-005	松线凸轮螺钉 Screw
		膝控提升杠杆(右)螺钉 Screw
11	36T6-004	松线杆 Thread releasing pin
12	22T7-007C1	膝控提升杠杆(右) Knee lifter lever (right)
13	22T7-007C2	膝控提升杆(右)弹簧 Coil spring
14	22T7-007C3	膝控提升连杆 Knee lifter connecting rod
15	22T7-008	弹簧销 Pin for spring
16	22T7-009	压紧杆轴套 Bushing for presser bar
17	22T7-010	压紧杆 Presser bar
18	22T7-011D1	压紧杆导架 Presser bar guide bracket
19	36T6-007	压紧杆导架螺钉 Screw
20	22T7-012	压紧杆弹簧导柱 Presser spring guide
21	48T7-002	压紧杆弹簧 Presser spring
22	22T7-014E1	调压螺钉 Thumb screw
23	22T7-014E2	调压螺钉锁紧螺母 Lock nut
24	22T7-015	压脚螺钉 Screw
25	22T7-017F	压脚组件 Presser foot asm
	48T7-003A	压脚组件 Presser foot asm
26	36T6-009	大线勾 Thread guide
27	22T2-004	大线勾螺钉 Screw
28	57T7-002	压脚护簧 Presser foot spring

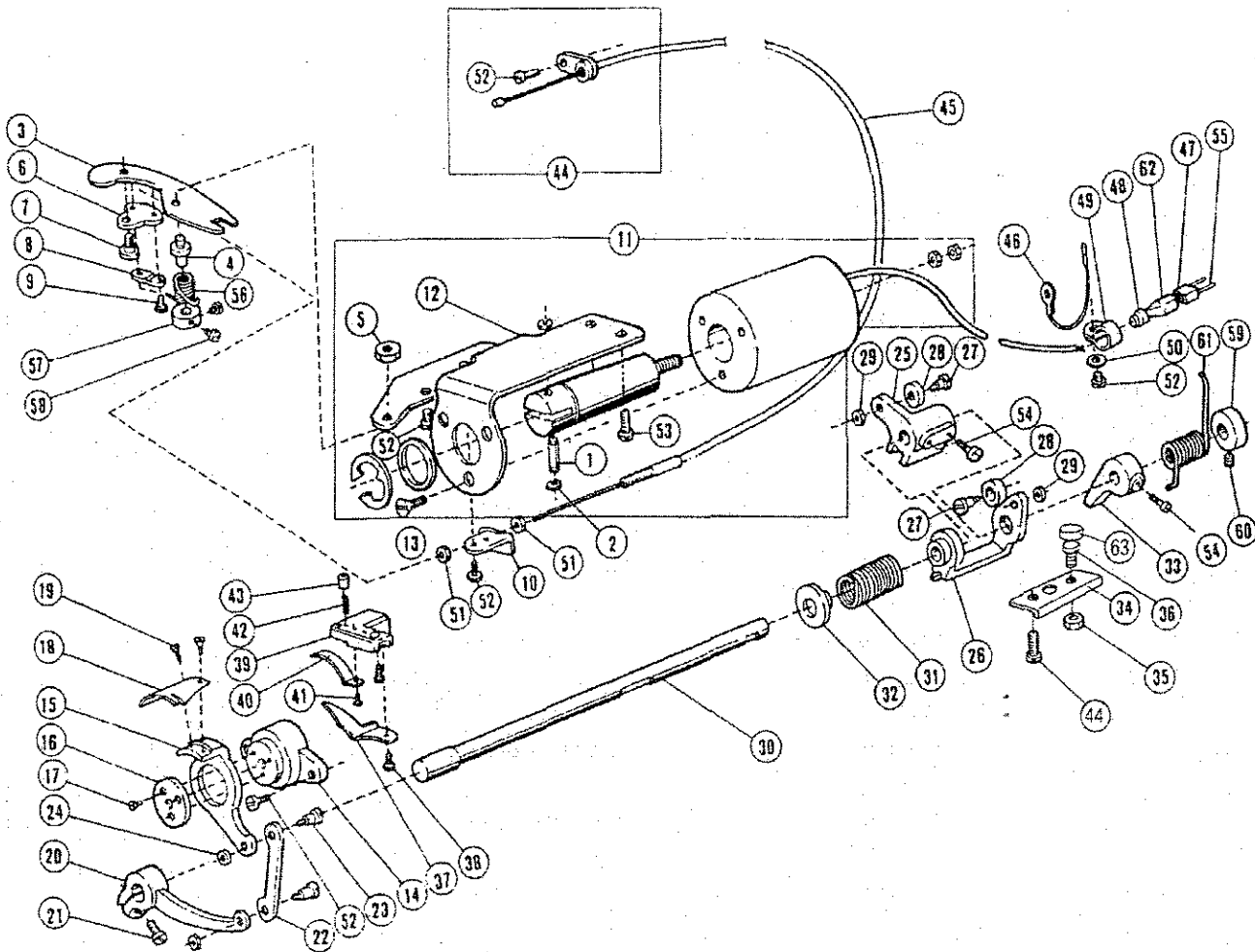

KNIFE ACTUATING MECHANISM

No.	Part No.	Description
1	36T8-009	切线电磁铁销 Pin
2	GB896-76	开口挡圈 Split retaining ring
3	36T7-001A1	挠性驱动板 Flexible driving lever
4	36T7-001A2	驱动板螺钉 Screw
5	J0.0.16	驱动板螺母 Nut
6	36T7-001A3	软线支撑板 Bracket for flexible wire
7	36T7-001A4	软线支撑板螺钉 Screw
8	36T7-001A5	软线连板 Flexible wire connecting bracket
9	36T7-001A6	软线连板螺钉 Screw
10	36T7-001A7	软线座 Holder for flexible wire
11	165710000	切线电磁铁组件 Solenoid assy for threaded trimmer
12	36T7-001A8b	切线电磁铁架 Solenoid mounting bracket
13	GB68-76	切线电磁铁螺钉 Screw
14	36T7-002B1a1	刀架鞍座 Knife holding saddle
15	36T7-002B1a2	刀架(左) knife base(left)
	120T7-001A1	刀架(左) knife base(left)
16	36T7-002B1a3	刀架垫圈 Washer
17	36T7-002B1a4	刀架螺钉 Screw
18	36T7-002B2	刀片(左) Blade(left)
	120T7-001A2	刀片(左) Blade
19	36T7-002B3	刀片紧固螺钉 Set screw

KNIFE ACTUATING MECHANISM

No.	Part No.	Description	Description
20	36T7-002B4	切刀驱动曲柄	Knife driving crank
21	61-04-01/B6	切刀驱动曲柄螺钉	Screw
22	36T7-002B5	刀轴连杆	Link
23	36T7-002B6	刀轴连杆螺钉	Screw
24	36T7-002B7	刀轴连杆螺母	Nut
25	36T7-003C1	凸轮曲柄(1)	Cam follower crank(1)
26	36T7-003C2	凸轮曲柄(2)	Cam follower crank(2)
27	36T7-003C3	滚柱轴	Roller stud
28	36T7-003C4	凸轮曲柄滚柱	Roller
29	36T7-003C5	滚柱螺母	Nut
30	36T7-004	切刀驱动轴	Knife driving shaft
	120T7-002	切刀驱动轴	Knife driving shaft
31	36T7-005	驱动轴弹簧	Coil spring
32	36T7-006	扭簧端盖	Bushing
33	165720004	限位块	Stopper
34	165720001	限位板	Stopper plate
35	GB6172-86-M6	限位板螺母	Nut
36	165720002	限位板螺钉	Screw
37	36T7-009E1	拦线板	Thead guide
	120T7-003B1	拦线板	Thead guide
38	J0.0.72	拦线板螺钉	Screw
39	36T7-009E2	定刀片固定架	Bracket for fixed blade
40	36T7-009E3	定刀片	Fixed knife
	120T7-003B2	定刀片	Fixed knife
41	36T7-009E4	定刀片紧固螺钉	Set screw
42	36T7-009E5	定刀片调节螺钉	Adjusting screw
43	36T7-009E6	定刀片调节螺母	Adjusting nut
44	36T8-002	限位板固定螺钉	Screw
45	36T7-010F	软线组件	Flexible wire asm
46	36T7-011G	接地线组件	Earth wire asm
47		插头	Plug
48	36T7-013	橡皮套	Rubber sleeve
49	36T7-014	导线夹头	Wire clamp
50	GB848-76	垫圈	Washer
51	GB54-76	软线螺母	Nut
52	22T2-019	螺钉 4.37 x 40/8	Screw 4.37 x 40/8
53	36T8-002	切线电磁铁架固定螺钉	Screw
54	22T5-010D4	螺钉	Screw
55	36T9-001A2a2	凸型插针	Pin
56	36T7-001A9	挠性驱动板扭簧	Coil spring
57	36T7-001A10	驱动板紧圈	Collar for driving lever
58	36T5-008E8	驱动板紧圈螺钉	Screw
59	36T7-015H1	驱动轴紧圈	Collar for knife driving shaft
60	22T3-002B1	驱动轴紧圈螺钉	Screw
61	36T7-016	驱动轴扭簧	Coil spring
62	36T7-017	插头护套	Guard for plug
63	165720003	缓冲垫	Rubber washer

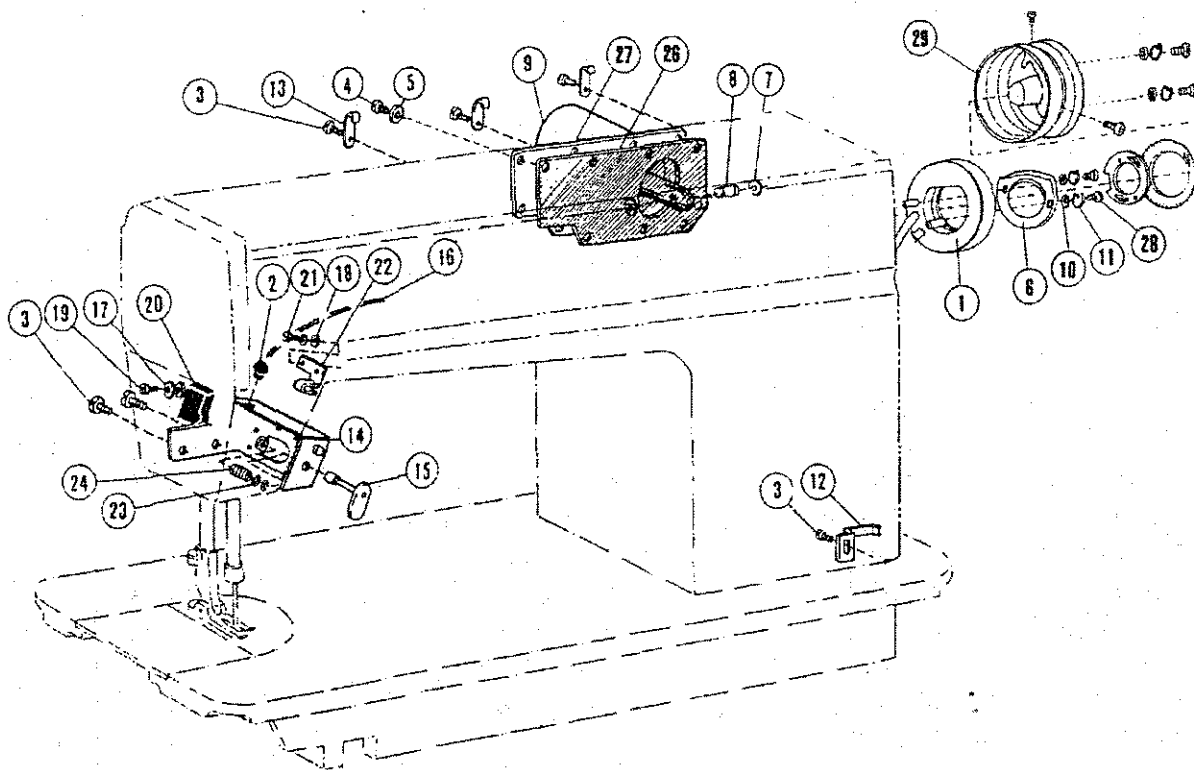

REVERSE SEWING MECHANISM

No.	Part No.	Description	Description
1	001D3 -001A	检测器组件	Detector componts
2	36T7 -014	橡皮套	Rubber plug
3	22T2 -019	螺钉	Screw
4	22T1 -006	后盖板螺钉	Screw
5	22T1 -007	后盖板螺钉垫片	Washer
6		检测器压板	Detector presser plate
7	GB896 -76	开口挡圈 4	Split washer 4
8	36T8 -009	倒缝电磁铁销	Pin
9	165820002	倒缝电磁铁	Electric -magnet for reverse sewing
10	GB97.1 -85	垫圈	Washer
11	GB859 -87	弹簧垫圈	Spring washer 3
12	36T8 -005	总线夹	Cord holder
13	36T8 -006	电线夹	Wire clamp
14	36T8 -007C1	开关安装架	Switch bracket
15	36T8 -007C2a	按钮组件	Button asm
16	36T8 -007C3b	倒缝开关组件	Cable for switch at reverse sewing
17	GB859 -76	弹簧垫圈 2	Spring washer 2
18	GB848 -76	垫圈 2	Washer 2
19	GB818 -85	微动开关螺钉	Screw
20	36T8 -007C4	微动开关	Micro switch
21	GB66 -76	片簧螺钉	Screw
22	36T8 -007C5	片簧	Leaf spring
23	GB896 -76	开口挡圈 3	Split retaining ring 3
24	36T8 -007C6	开口弹簧	Coil spring
26	36T8 -008E1	后盖板密封垫片	Gasket
27	165820001	后盖板	Side cover
28		螺钉	Screw
29	165320001	主动轮配件	Balance wheel asm

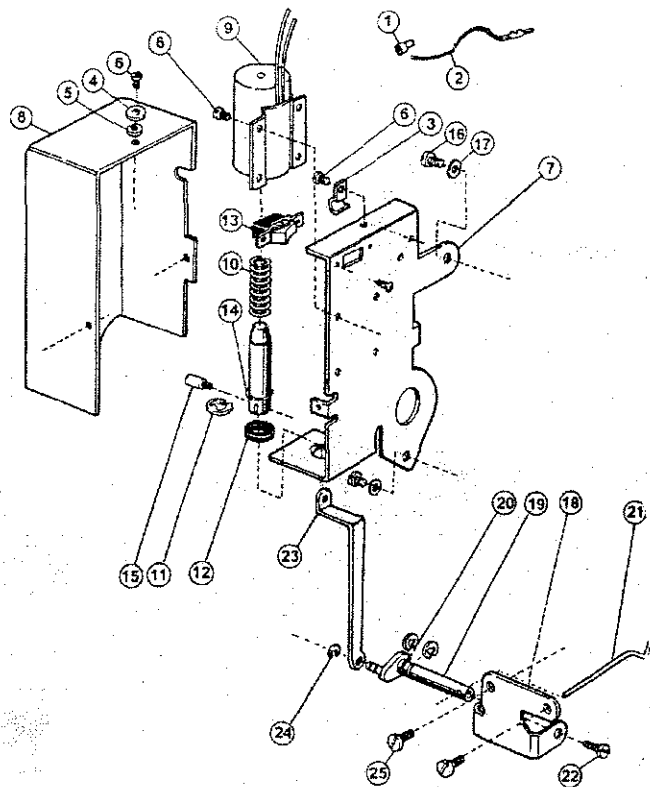

WIPER MECHANISM

No.	Part No.	Description	Description
1	36T9-001A1	电线接头	Wire connector
2	36T9-001A2a	挡线电磁铁导线组件	Wire
3	36T9-001A3	线夹	Cord clamp
4	GB848-76	螺钉垫圈	Washer
5	GB859-76	弹簧垫圈	Washer
6	GB818-76	磁铁盖螺钉	Screw
7	36T9-001A4	电磁铁安装架	Solenoid bracket
8	36T9-001A5	挡线电磁铁盖	Cover for wiper mech
9	36T9-001A6	挡线电磁铁	Solenoid for wiper
10	36T9-001A7	螺旋弹簧	Coil spring
11	GB896-76	挡圈	Retaining ring
12	36T9-001A8	橡皮圈	Rubber ring
13	36T9-001A9	挡线开关	Switch for wiper
14	36T9-001A10	垫圈	Washer
15	36T9-002	衔铁螺钉	Screw
16	22T5-001A4	安装架螺钉	Screw
17	36T9-003	安装架螺钉垫圈	Washer
18	36T9-004B1	挡线轴安装架	Wiper bracket
19	36T9-004B2a	挡线摆动轴组件	Wiper shaft asm
20	G896-76	挡圈	Retaining ring4
21	36T9-004B3	挡线勾	Wiper
22	22T6-001A4	紧固螺钉	Screw
23	36T9-004B4	挡线连杆	Link
24	GB896-76	挡圈	Retaining ring
25	36T9-005	挡线轴安装架螺钉	Screw

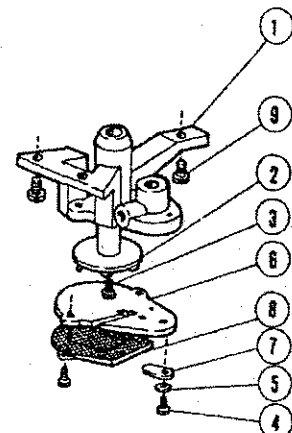
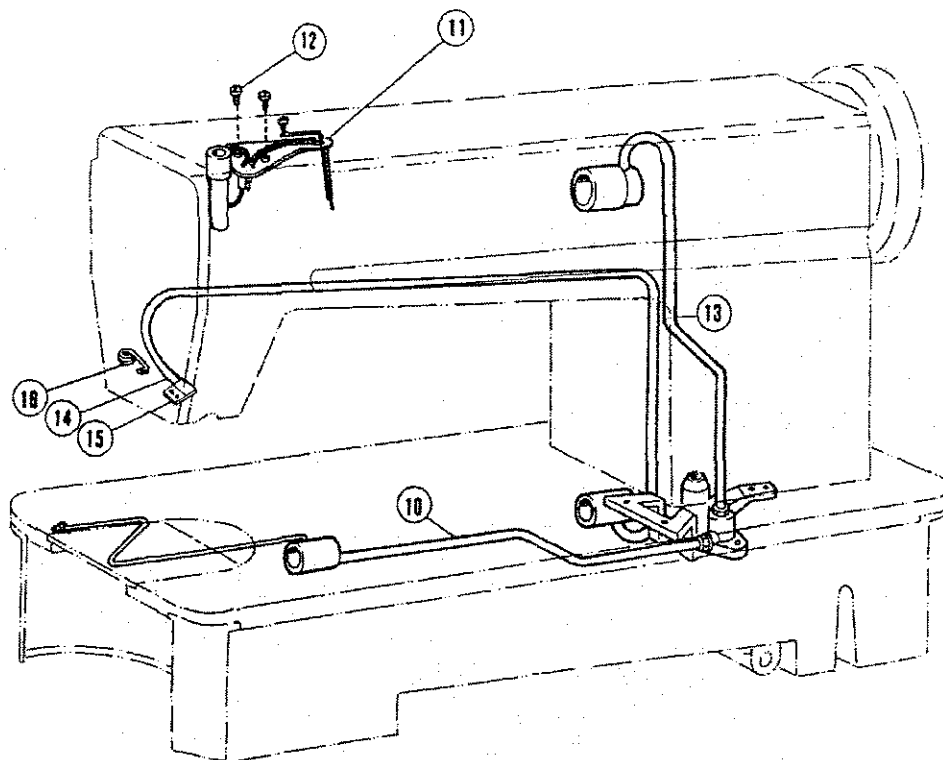

OIL PUMP MECHANISM

No.	Part No.	Description
1	22T8 -001	油泵体 Oil pump
2	22T8 -002	油泵叶轮 Oil pump impeller
3	22T8 -003	油泵叶轮螺钉 Screw
4	22T8 -004	油泵调节板螺钉 Screw
5	22T8 -005	油泵调节板螺钉弹簧垫圈 Springee washer
6	22T8 -006	油泵体盖板 Oil pump fitting plate
7	22T8 -007	油量调节板 Oil adjusting plate
8	22T8 -008A	油泵滤网组件 Oil pump screen asm
9	22T8 -009	油泵体螺钉 Screw
10	36T10 -001A	下轴油管组件 Oil pump for hook shaft
11	22T8 -011C	油线固定板大组件 Oil braid fitting plate
12	22T8 -012	油线固定板螺钉 Screw
13	22T8 -013D	上轴油管组件 Oil pump for arm shaft
14	22T8 -014	回油管 Oil return pipe
15	22T8 -015	回油管滤油毡 Felt pouch for return oil filter
16	36T10 -002	回油管夹 Oil filter holder

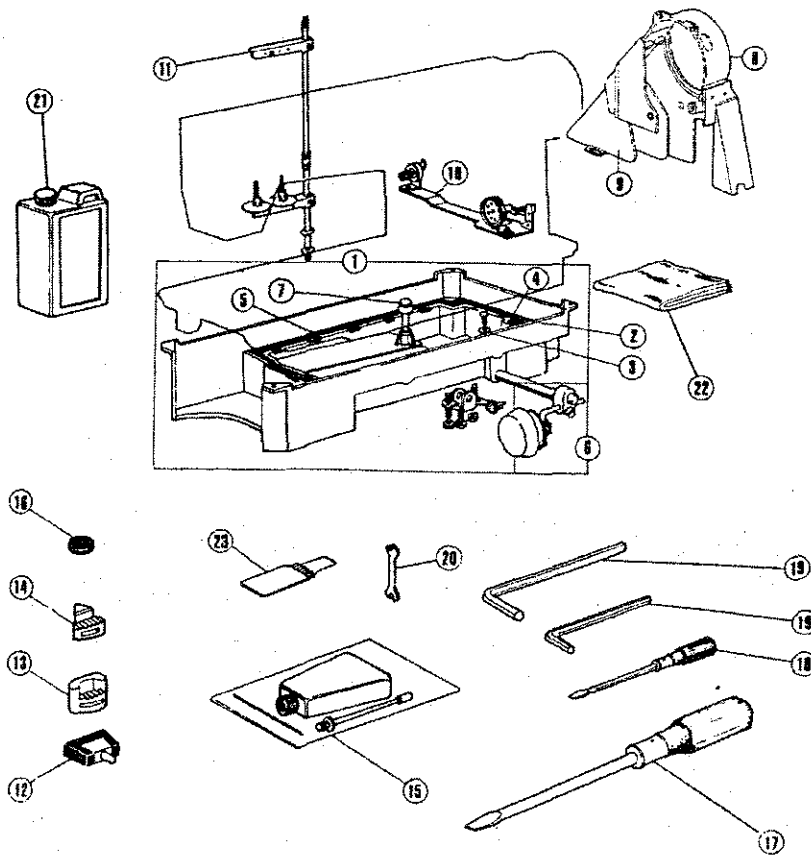

OIL RESERVOIR & ACCESSORIES

No.	Part No.	Description	Description
1	36T11 -001A	油盘组件	Oil reservoir asm
2	22T9 -001A2	放油螺钉	Screw
3	22T9 -001A3	放油螺钉垫圈	Washer
14	22T9 -001A4	油盘垫(小)	Oil gasket (S)
5	22T9 -001A5	油盘垫(大)	Oil gasket (B)
6	22T9 -003B	膝控磁块组件	Knee lifter asm
7	22T9 -003B1	膝控提升顶杆	knee lifter lifting pin
8	124T9 -003B	皮带罩组件	Belt cover
9	124T9 -004C	小皮带罩组件	Belt cover (S)
10	6F0	绕线器组件	Thread winder asm (large hook)
11	GXJ -2	线架组件	Thread spool asm
12	22T9 -007F	机壳铰链组件	Hinge with rubber cushion
13	22T9 -009	机头防震垫块(大)	Cushion (B)
14	22T9 -010	机头防震垫块(小)	Cushion (S)
15	22T9 -011	小油壶	Oil pot
16	22T9 -012	磁块	Magnet block
17	22T9 -013	螺钉起子(长)	Screw drive (long)
18	22T9 -015	螺钉起子(短)	Screw drive (short)
19	36T11 -006	内六角扳手 M4 M6	Allen wrench M4 M6
20	22T9 -016	双头扳手	Double open - end wrench
21	22T9 -017	油箱	Oil tank
22	22T9 -018	机罩	Machine head cover
23	22T9 -024	机针袋	Needle bag

Consolidated Sewing Machine Corp.

Website: www.consew.com

MAIN office

131 W. 25th Street
New York, NY 10001
Tel: 212-741-7788
Fax: 212-741-7787
e-mail: consew@att.net

Miami, FL

4013 N.W. 79th Avenue
Miami, FL 33166
Tel: 305-471-0200
Fax: 305-471-0243
e-mail: miamisales@consew.com

Los Angeles, CA

2320 South Hill Street
Los Angeles, CA 90007
Tel: 213-745-8844
Fax: 213-745-8855
e-mail: lasales@consew.com