



DIRECT DRIVE
LARGE WORKSPACE

Since 1898
CONSEW®

Model P1510RB-DD and -7DD series SINGLE NEEDLE

Designed for automotive, marine, leather, canvas and general upholstery.

The Automatic Footlift and Reverse on these machines operates Pneumatically (Air) and require a compressed air source (not supplied by Consew.)

Automatic Function Machines (-DD)

The (-DD) does NOT have the Automatic Thread Trim

P1510RB-14-DD/220 14"

P1510RBL-18-DD/220 18"

P1510RBL-25-DD/220 25"

Currently Available in 220V 1-phase Version ONLY.

Full Automatic Function Machines (-7DD)

The (-7DD) has Automatic Thread Trim

P1510RB-14-7DD/220 14"

P1510RBL-18-7DD/220 18"

P1510RBL-25-7DD/220 25"

Currently Available in 220V 1-phase Version ONLY.

**AUTOMATIC
FUNCTIONS**

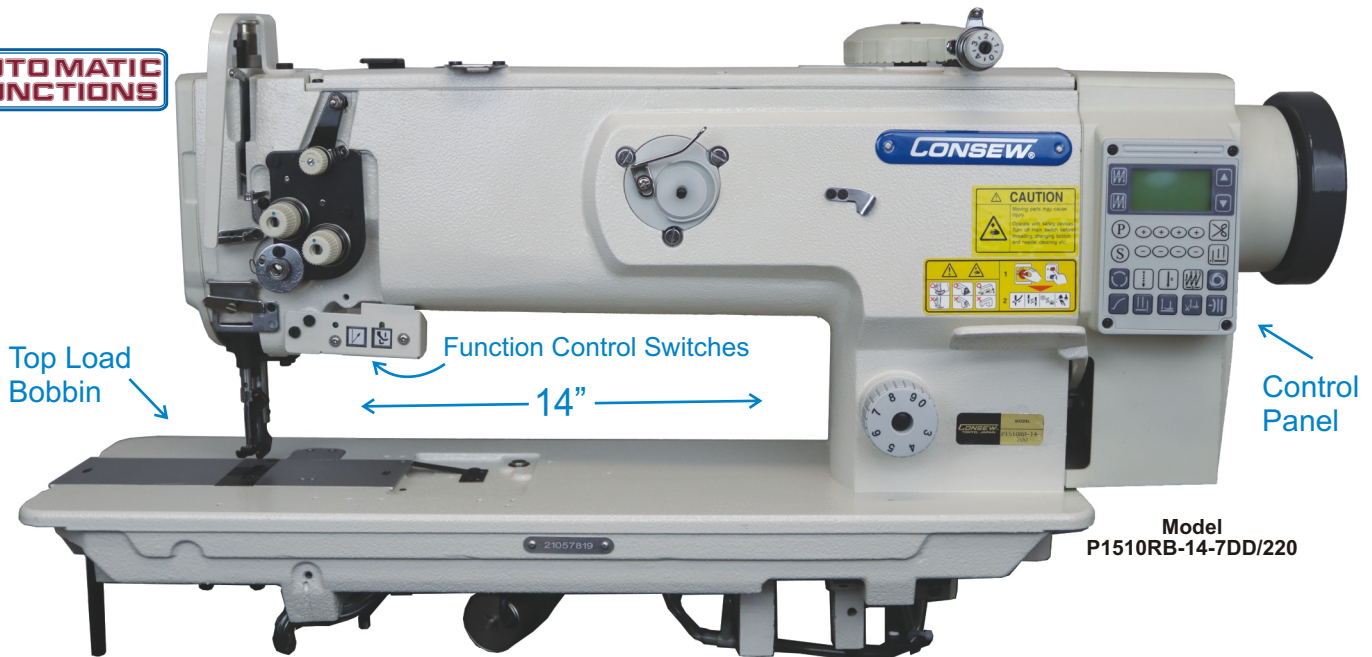

The major difference between the 1510RB-DD series and 1510RB-7DD series is that the -DD series does **not** include the Auto Thead Trimmer

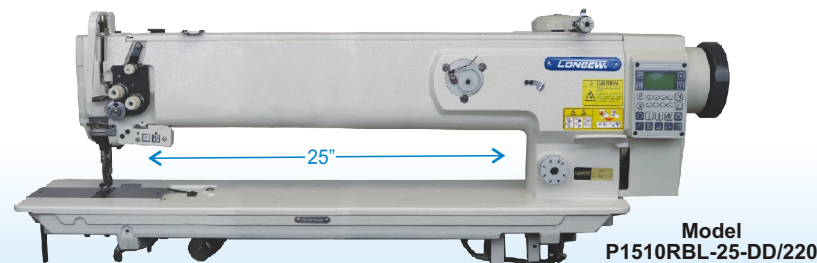

Automatic Functions
High Speed
Direct Drive
(Servo Motor connected to Top Shaft)

Single Needle
Walking Foot
Lockstitch Machines

Automatic Function Machines (-DD) No Auto Thread Trim

- P1510RB-14-DD/220** 14" workspace
- P1510RBL-18-DD/220** 18"
- P1510RBL-25-DD/220** 25"

Full Automatic Function Machines (-7DD) with Auto Thread Trim

- P1510RB-14-7DD/220** 14" workspace
- P1510RBL-18-7DD/220** 18"
- P1510RBL-25-7DD/220** 25"

APPLICATIONS

- For sewing light to heavy-weight fabric, canvas, leather, vinyl, synthetics and various laminated and coated materials
- Designed for stitching such products as auto, boat and furniture upholstery, tarpaulins, covers, awnings, tents, umbrellas, handbags, luggage, travelware accessories, sports and camping equipment, wearing apparel, outdoor clothing, footwear, foundation garments, orthopedic appliances, etc.

Features for -7DD

- Large Top Load Bobbins
- Built-in Bobbin Winder
- Walking Foot
- Climbing Device
- Roll-In, tucks the top thread under fabric when it starts!
- Automatic Foot Lift
- Automatic Reverse
- Semi-Autopmatic Lubrication
- Automatic Thread Trim (on -7DD only)

Features for -DD

- Same as -7DD except it does NOT have the Automatic Thread Trim



Control Panel

P1510RB-14-7DD/220V

This is a fully automatic machine, and includes the air cylinders for the **footlift, reverse feed** functions.

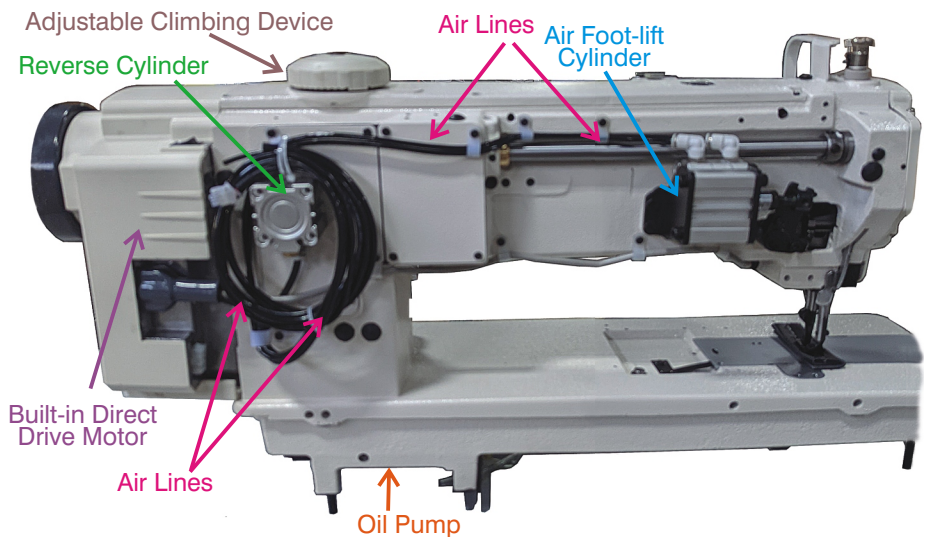

SPECIFICATIONS

P1510RB series

Speed, Max. (S.P.M.)	*	2500 - 3000*
Clearance Under Foot		9/16" (14mm)
Presser Foot Lift	By Hand:	(9 mm)
	By Knee:	(16 mm)
Stitch Length, Max.		Max. 9mm adjustment by dial
Needle		135 x 17
Bobbin	Pre-wound	U or S
Work Space		14"(355 mm), 18"(457 mm) 25"(635 mm)
Stitch Type		301

Currently Available in 220v 1-phase Version ONLY.

* Speed depends on thread, material and operation.

THREAD TRIMMER ON -7DD



SINGLE NEEDLE WALKING FOOT

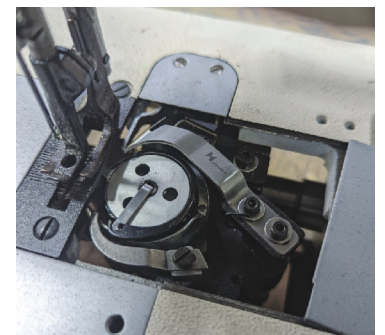

Thread Trimmer Knife

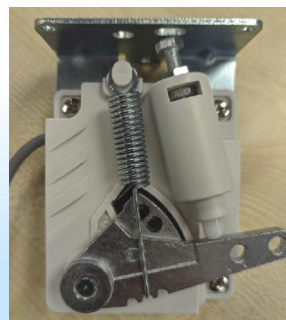

Treadle control lever.

This is plugged in to the motor's electronics and is connected to the foot treadle with the treadle rods



Thread Trimmer Solenoid