



**P1510RB-14**

**P1510RB-14-(N)**

**P1510RB-14-7DD**

**P1560RB-14**

**P1560RB-14-(N)**

**P1560RB-14-7DD**

**PARTS BOOK  
AND INSTRUCTION MANUAL**



## IMPORTANT SAFETY INSTRUCTIONS

Putting sewing systems into operation is prohibited until it has been ascertained that the sewing systems in which these sewing machines will be built into, have conformed with the safety regulations in your country. Technical service for those sewing systems is also prohibited.

1. Observe the basic safety measures, including, but not limited to the following ones, whenever you use the machine.
2. Read all the instructions, including, but not limited to this Instruction Manual before you use the machine. In addition, keep this Instruction Manual so that you may read it at anytime when necessary.
3. Use the machine after it has been ascertained that it conforms with safety rules/standards valid in your country.
4. All safety devices must be in position when the machine is ready for work or in operation. The operation without the specified safety devices is not allowed.
5. This machine shall be operated by appropriately-trained operators.
6. For your personal protection, we recommend that you wear safety glasses.
7. For the following, turn off the power switch or disconnect the power plug of the machine from the receptacle.
  - 7-1 For threading needle(s), looper, spreader etc. and replacing bobbin.
  - 7-2 For replacing part(s) of needle, presser foot, throat plate, looper, spreader, feed dog, needle guard, folder, cloth guide etc.
  - 7-3 For repair work.
  - 7-4 When leaving the working place or when the working place is unattended.
  - 7-5 When using clutch motors without applying brake, it has to be waited until the motor stopped totally.
8. If you should allow oil, grease, etc. used with the machine and devices to come in contact with your eyes or skin or swallow any of such liquid by mistake, immediately wash the contacted areas and consult a medical doctor.

9. Tampering with the live parts and devices, regardless of whether the machine is powered, is prohibited.
10. Repair, remodeling and adjustment works must only be done by appropriately trained technicians or specially skilled personnel. Only spare parts designated by us can be used for repairs.
11. General maintenance and inspection works have to be done by appropriately trained personnel.
12. Repair and maintenance works of electrical components shall be conducted by qualified electric technicians or under the audit and guidance of specially skilled personnel. Whenever you find a failure of any of electrical components, immediately stop the machine.
13. Before making repair and maintenance works on the machine equipped with pneumatic parts such as an air cylinder, the air compressor has to be detached from the machine and the compressed air supply has to be cut off. Existing residual air pressure after disconnecting the air compressor from the machine has to be expelled. Exceptions to this are only adjustments and performance checks done by appropriately trained technicians or specially skilled personnel.
14. Periodically clean the machine throughout the period of use.

15. Grounding the machine is always necessary for the normal operation of the machine. The machine has to be operated in an environment that is free from strong noise sources such as high-frequency welder.
16. An appropriate power plug has to be attached to the machine by electric technicians. Power plug has to be connected to a grounded receptacle.

17. The machine is only allowed to be used for the purpose intended. Other uses are not allowed.
18. Remodel or modify the machine in accordance with the safety rules/standards while taking all the effective safety measures. We assume no responsibility for damage caused by remodeling or modification of the machine.

19. Warning hints are marked with the two shown symbols.



Danger of injury to operator or service staff



Items requiring special attention

## SAFETY DEVICE AND CAUTION

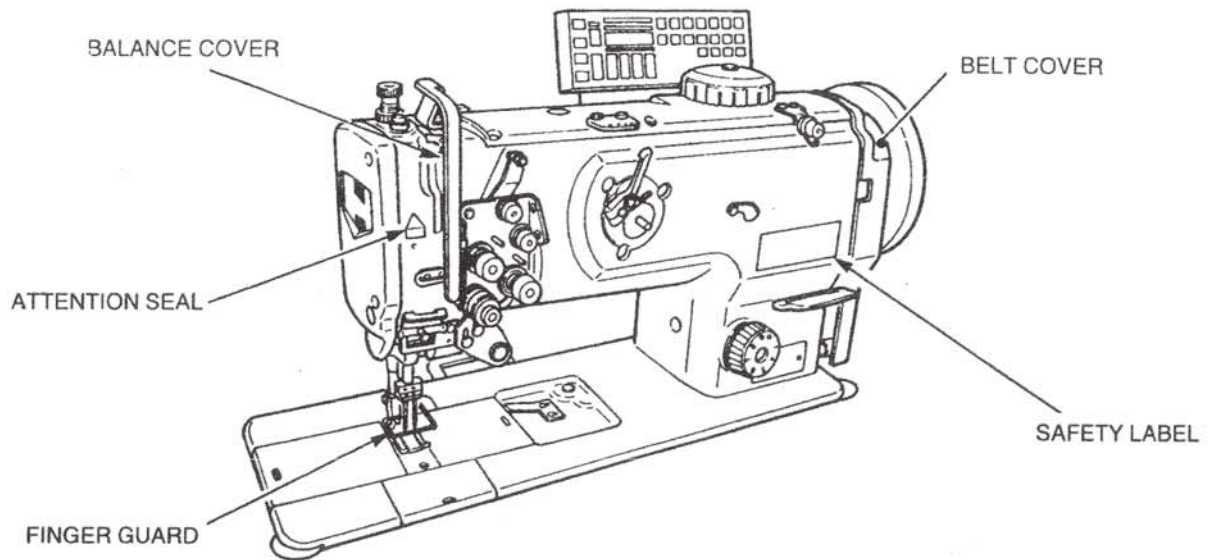

### FOR SAFE OPERATION



1. Keep your hands away from needle when you turn ON the power switch or while the machine is in operation.
2. Do not put your fingers into the thread take-up cover while the machine is operating.
3. Turn OFF the power switch when tilting the machine head, or removing the belt cover or the V belts.
4. During operation, be careful not to allow your or any other person's head, hands or clothes to come close to the handwheel, V belt and motor. Also, do not place anything close to them.
5. Do not operate your machine with the belt cover and finger guard removed.
6. When tilting the machine head, be sure to confirm that the head support bar is properly attached to your machine head, and be careful not to allow your fingers or the like to be pinched in the machine head. In addition, when the machine is used with the control panel, do not tilt or raise the machine head while holding the control panel.



1. To ensure safety, never operate the machine with the ground wire for the power supply removed.
2. When inserting/removing the power plug, the power switch has to be turned OFF in advance.
3. In time of thunder and lightning, stop your work and disconnect the power plug from the receptacle so as to ensure safety.
4. If the machine is suddenly moved from a cold place to a warm place, dew condensation may be observed. In this case, turn ON the power to the machine after you have confirmed that there is no danger of water drops in the machine.



#### CAUTION:

Note that safety devices such as "belt cover", "finger guard", etc. may be omitted from the illustrations in this Instruction Manual for easy explanation. When operating the machine, be sure not to remove these safety devices.

## CONTENTS

BEFORE OPERATION.....	II
SPECIFICATIONS.....	III
1.INSTALLATION.....	1
2.INSTALLING THE WASTE OIL CONTAINER.....	2
3.ADJUSTING THE BELT TENSION.....	2
4.ADJUSTING THE STOP POSITION (1560N-7,1561N-7).....	2
5.ATTACHING THE BELT COVER.....	3
6.THE AIR DRIVE UNIT OF THE SEWING MACHINE EQUIPPED WITH AUTOMATIC REVERSE FEED DEVICE/AUTO-LIFTER (1560N-7,1561N-7).....	4
7.LUBRICATION.....	5
8.ATTACHING THE NEEDLE.....	7
9.ATTACHING/REMOVING THE BOBBIN.....	7
10.THREADING THE HOOK.....	8
11.INSTALLING THE BOBBIN WINDER THREAD GUIDE.....	8
12.WINDING A BOBBIN.....	9
13.THREADING THE MACHINE HEAD.....	9
14.ADJUSTING THE STITCH LENGTH.....	10
15.THREAD TENSION.....	10
16.THREAD TAKE-UP SPRING.....	11
17.HAND LIFTER.....	11
18.ADJUSTING THE PRESSURE OFTHE PRESSER FOOT.....	12
19.NEEDLE-TO-HOOK RELATION.....	12
20.ADJUSTING THE HOOK NEEDLE GUARD.....	13
21.ADJUSTING THE BOBBIN CASE OPENING LEVER.....	13
22.POSITION OF THE COUNTER KNIFE AND ADJUSTMENT OF THE KNIFE PRESSURE (1560N-7, 1561 N-7).....	14
23.ADJUSTING THE LIFTING AMOUNT OF THE PRESSER FOOTAND THE WALKING FOOT .....	14
24.SEWING SPEED TABLE.....	15
25.MOTOR PULLEY AND V BELT.....	16
26.RESETTING THE SAFETY CLUTCH.....	16
27.ADJUSTING THE AUTOMATIC PRESSER FOOT LIFTER (OPTIONAL).....	17
28.TROUBLES IN SEWING AND CORRECTIVE MEASURES.....	18

## BEFORE OPERATION



### CAUTION:

Check the following so as to prevent maloperation of and damage to the machine.

- Before you put the machine into operation for the first time after the set-up, clean it thoroughly. Remove all dust gathering during transportation and oil it well.
- Confirm that voltage has been correctly set.  
Confirm that the power plug has been properly connected to the power supply.
- Never use the machine in the state where the voltage type is different from the designated one.
- The direction of normal rotation of the machine is counterclockwise as observed from the pulley side.
- Take care not to allow the machine to rotate in the reverse direction.
- When tilting the machine head, tilt it after removing knee lifter hook.
- Never operate the machine unless the machine head and the oil tank have been filled with oil.
- For a test run, remove the bobbin and the needle thread.
- For the first month, decrease the sewing speed and run the sewing machine at a speed of 2,000 rpm or less.
- Operate the handwheel after the machine has totally stopped.

## SPECIFICATIONS

Model	1560N (Standard gauge type) 1561N (2260 gauge type)	1560N-7 (Standard gauge type) 1561N-7 (2260 gauge type)
Sewing speed	Max. 2,500 rpm See "24.SEWING SPEED TABLE" on page 51.	
Stitch length(max.)	Normal feed: 9 mm Reverse feed: 9 mm	
Needle	SCHMETZ 135 x 17 (Nm 125 to Nm 180) (Standard: Nm 160)	
Thread	#30 to #5 (US:#46 to #138, Europe:20/3 to 60/3)	
Hook	Vertical-axis 2.0-fold capacity hook	
Lift of presser foot	Hand lifter lever: 9 mm	
	Knee lifter :16 mm	Auto-lifter: 16 mm
Lubricating oil	New Defrix Oil No.2	
Noise	Workplace-related noise at sewing speed N=1,550 min <sup>-1</sup> : L <sub>PA</sub> ≤84 dB(A) Noise measurement according to DIN 45635-48-A-1	Workplace-related noise at sewing speed N=2,040 min <sup>-1</sup> : L <sub>PA</sub> ≤84 dB(A) Noise measurement according to DIN 45635-48-A-1

# 1. INSTALLATION

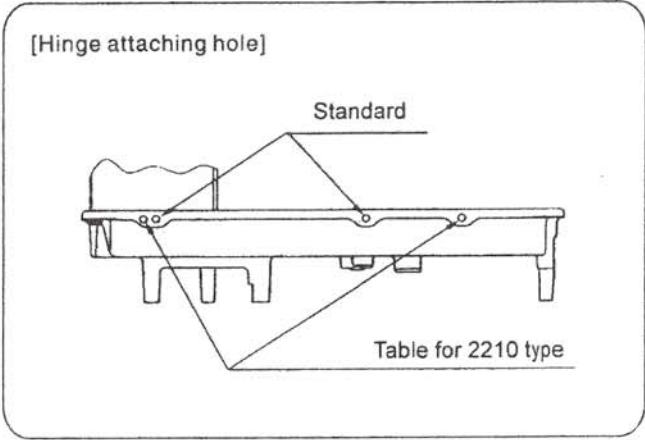
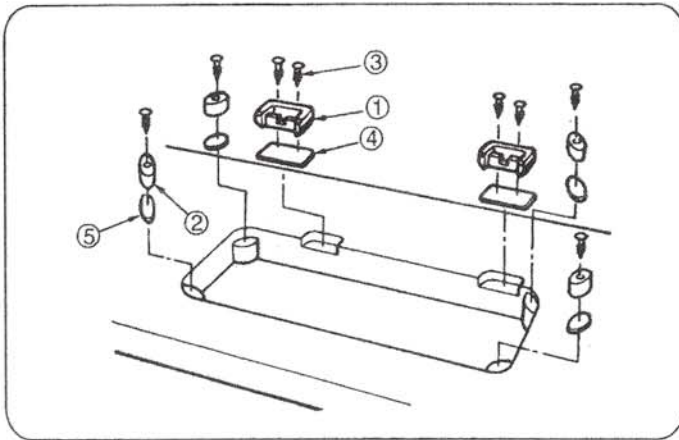

1) Attaching the hinge seats and the support rubbers of the machine head.

Fix the hinge seats ① and the support rubbers ② supplied with the machine on the table using nails ③.

\* If the slide plate comes in contact with the table when opening it, place spacer rubbers ④ and ⑤ supplied with the machine under support rubbers ② and hinge seats ①.

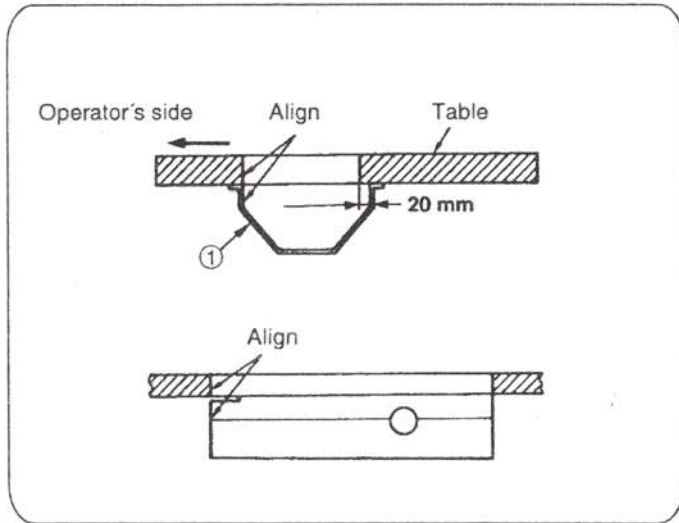

2) Attaching the oil pan

Fix the oil pan ① supplied with the machine by tightening eight wood screws.

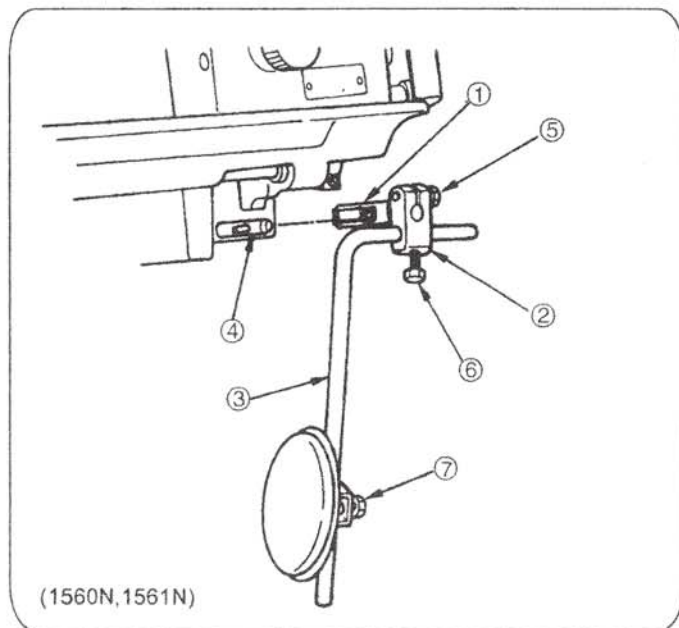

3) Adjust knee pad joint ①, knee lifter vertical shaft installing arm ② and knee pad lever ③ to the direction of knee lifter lever shaft ④ and assemble these components. (1560N, 1561N)

4) Adjust the direction of the pad with setscrews ⑤, ⑥ and ⑦. (1560N, 1561N)

(1560N, 1561N)

## 2. INSTALLING THE WASTE OIL CONTAINER

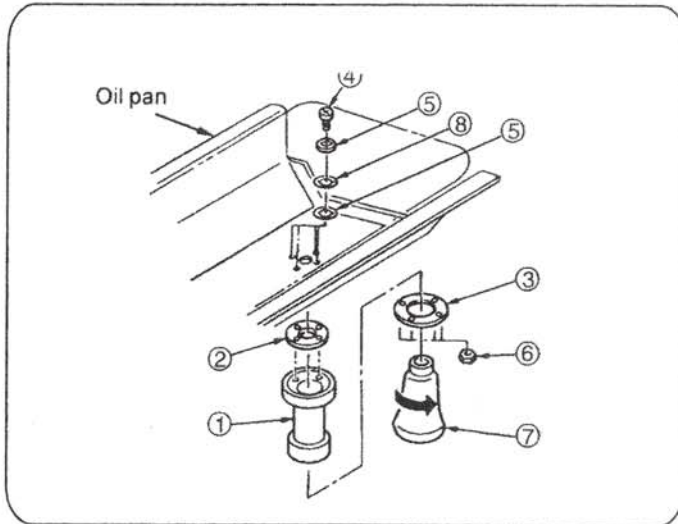

- 1) Attach drain plug ①, oil seal ② and washer ③ to the oil pan. Attach packing ⑤ and washer ⑧ to screw ④ and fix them with nut ⑥.
- 2) After they are fixed, screw in waste oil container ⑦ into drain plug ①.

## 3. ADJUSTING THE BELT TENSION



### WARNING:

To avoid possible personal injury due to abrupt start of the machine, turn off the power to the machine and check to be sure that the motor has totally stopped rotating in prior.

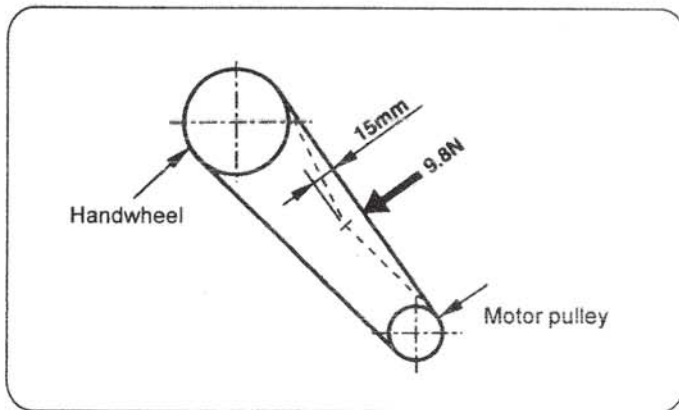

Adjust the belt tension with the height of the motor so that the belt sags 15 mm when the center of V belt is applied with a 9.8 N load.

## 4. ADJUSTING THE STOP POSITION (1560N-7,1561N-7)



### WARNING:

To avoid possible personal injury due to abrupt start of the machine, turn off the power to the machine and check to be sure that the motor has totally stopped rotating in prior.

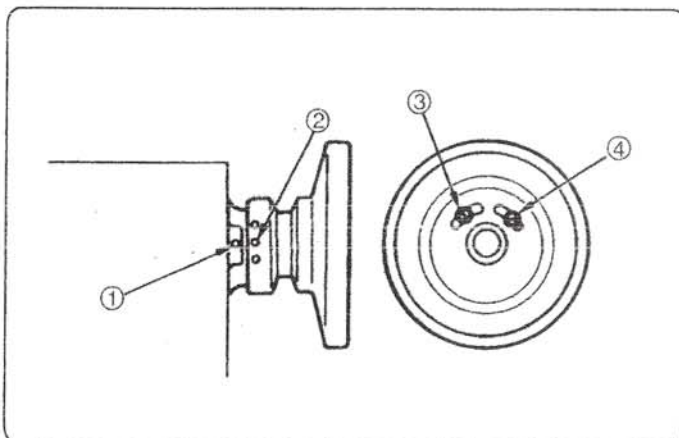

Marker dot on handwheel	
Center, White-White	Up stop position
Yellow	DOWN stop position
Red	For adjusting thread trimming cam
No color	Reverse revolution to lift needle position



- 1) The respective stop positions and adjusting positions are those when marker dot ① engraved on the machine arm aligns with marker dot ② engraved on the handwheel. For the marker dots engraved on the handwheel, refer to the table of marker dot on the handwheel.
- 2) In case of adjusting the UP stop position, adjust it with screw ③, and in case of adjusting the DOWN stop position, adjust it with screw ④.

## 5. ATTACHING THE BELT COVER



### WARNING:

To avoid possible personal injury due to abrupt start of the machine, turn off the power to the machine and check to be sure that the motor has totally stopped rotating in prior.

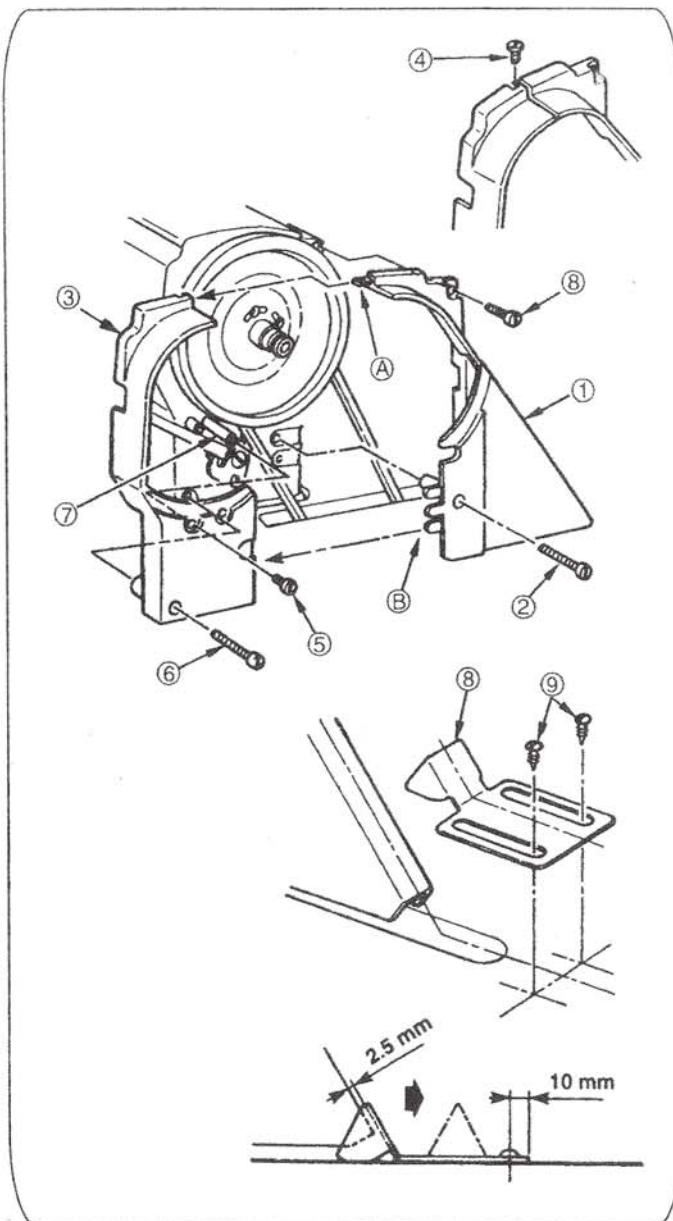

- 1) Attach belt cover stud ⑦ to the screw hole in the arm.
- 2) Fix belt cover (right) ① on the arm with screws ② and ⑧.
- 3) Fit belt cover (left) ③ to notch A and B of the belt cover(right).
- 4) Fix belt cover (left) ③ with screws ④, ⑤ and ⑥.
- 5) Fix belt cover auxiliary plate ⑧ at the position of 10 mm from the rear end with wood screws ⑨ when there is a clearance of 2.5 mm between the belt cover and the auxiliary plate.
- 6) When tilting the machine head, loosen wood screws ⑨ and move the belt cover auxiliary plate in the direction of the arrow until it stops. Then, tilt the machine head.

**(Caution)** After attaching the belt cover, confirm whether or not the respective cords do not come in contact with the belt and the handwheel. Disconnection of the cords will result when they come in contact

## 6. THE AIR DRIVE UNIT OF THE SEWING MACHINE EQUIPPED WITH AUTOMATIC DEVERSE FEED DEVICE AND AUTO-LIFTER(1560N-7,1561N-7)



### WARNING:

To avoid possible personal injury due to abrupt start of the machine, turn off the power to the machine and check to be sure that the motor has totally stopped rotating in prior.

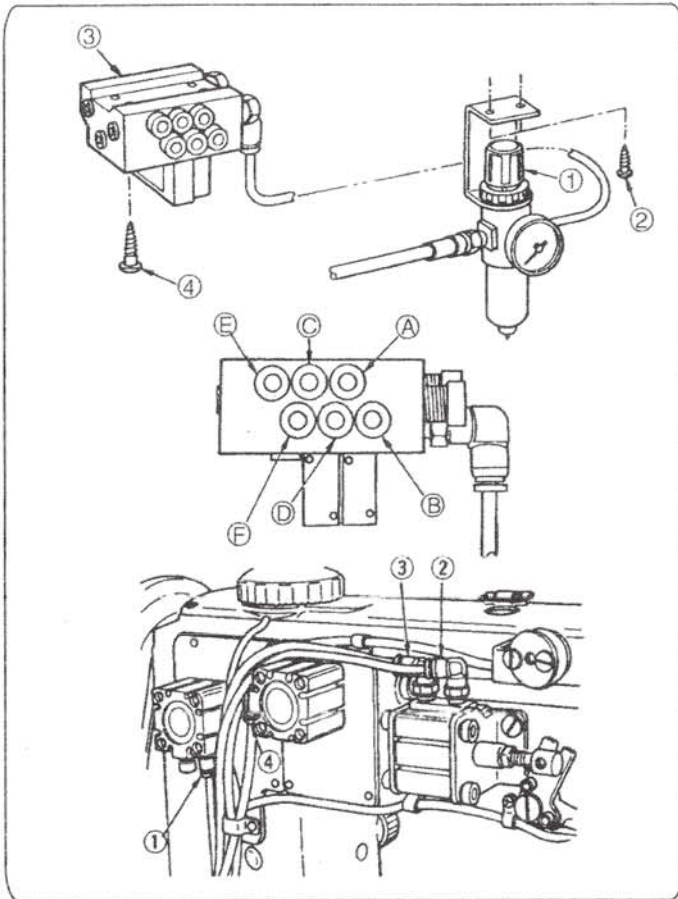

- 1) Attach regulator (asm.) ① to the underside of the table with wood screws ② supplied with the regulator.
- 2) Attach air control unit (asm.) ③ to the four places on the underside of the table with wood screws ④ supplied with the unit.
- 3) Adjust the number of the air hose to the number of the air cylinder joint and insert the hose to the joint.

**(Caution)** Do not run the sewing machine while the presser foot is held raised with the auto-lifter. Needle bar comes in contact with presser foot. As a result, they may be damaged.

	Solenoid valve	Cylinder
BT	Ⓐ	①
AK	Ⓒ	②
AK	Ⓓ	③
DL	Ⓑ	④
—	Ⓔ	—
—	Ⓕ	—

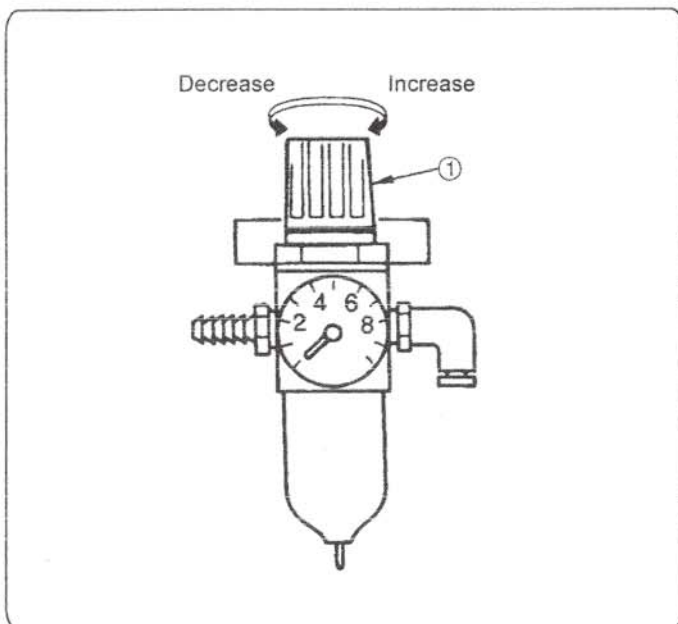

### (2) Adjusting the air pressure

The operating air pressure is 0.45 to 0.5 MPa.

Adjust the air pressure using air pressure regulating knob ① of the filter regulator.

## 7. LUBRICATION



### WARNING:

To avoid possible personal injury due to abrupt start of the machine, turn off the power to the machine and check to be sure that the motor has totally stopped rotating in prior.

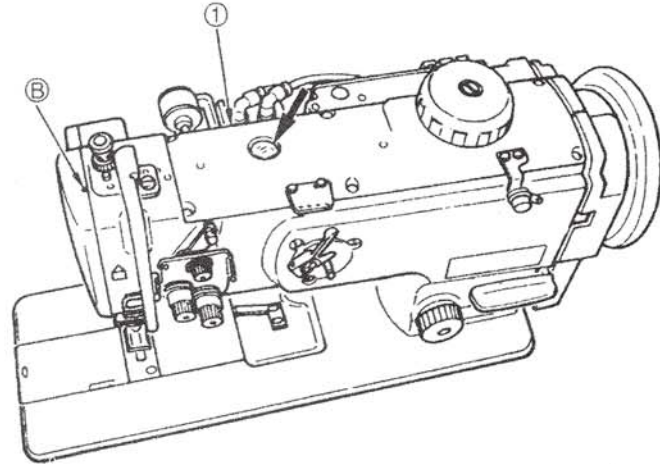
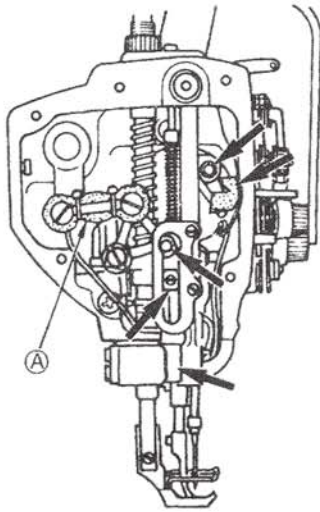

1) Prior to operation, apply an adequate amount of oil once a day to the points marked with the arrows **A**.

Prior to operation, apply one drop of oil once a day to the point marked with the arrow **B**.

\* You can apply oil to the point marked with **A** after removing the rubber cap without removing the face plate.

2) When you operate your machine for the first time after the set-up or after an extended period of disuse, apply an adequate amount of oil to the points marked with the arrows and to each felt and oil wick after removing top cover **1**.

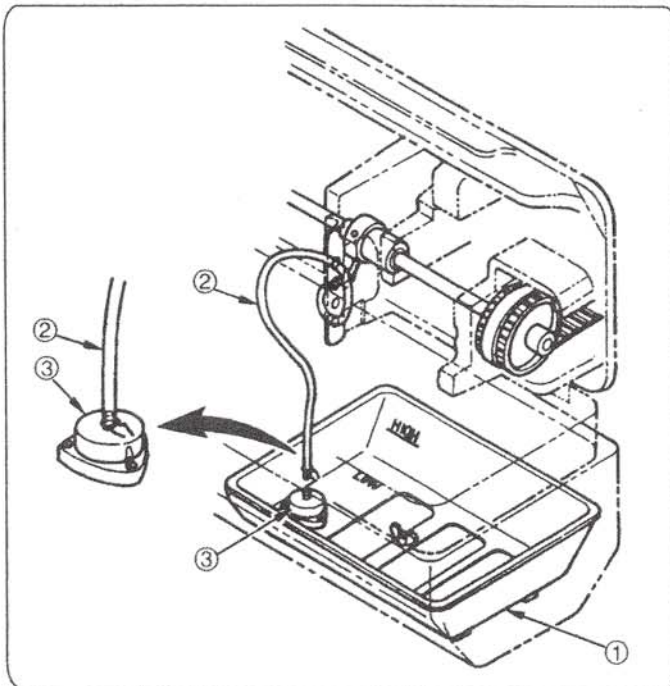

3) Insert the projection located at the bottom of oil tank **1** into the waste oil hole of the oil pan.

4) Insert oil pipe **2** into filter **3** of the oil tank and fix the pipe with a clip.

5) Pour the New Defrix Oil No. 2 into the oil tank until HIGH level is reached.

6) Add the same lubricating oil up to HIGH level as soon as the oil level has come down to LOW level.

7) After the lubrication, you can see from oil sight window **5** that the oil rises up when the operation is normal. (However, the machine should run at 1,500 rpm or more.)

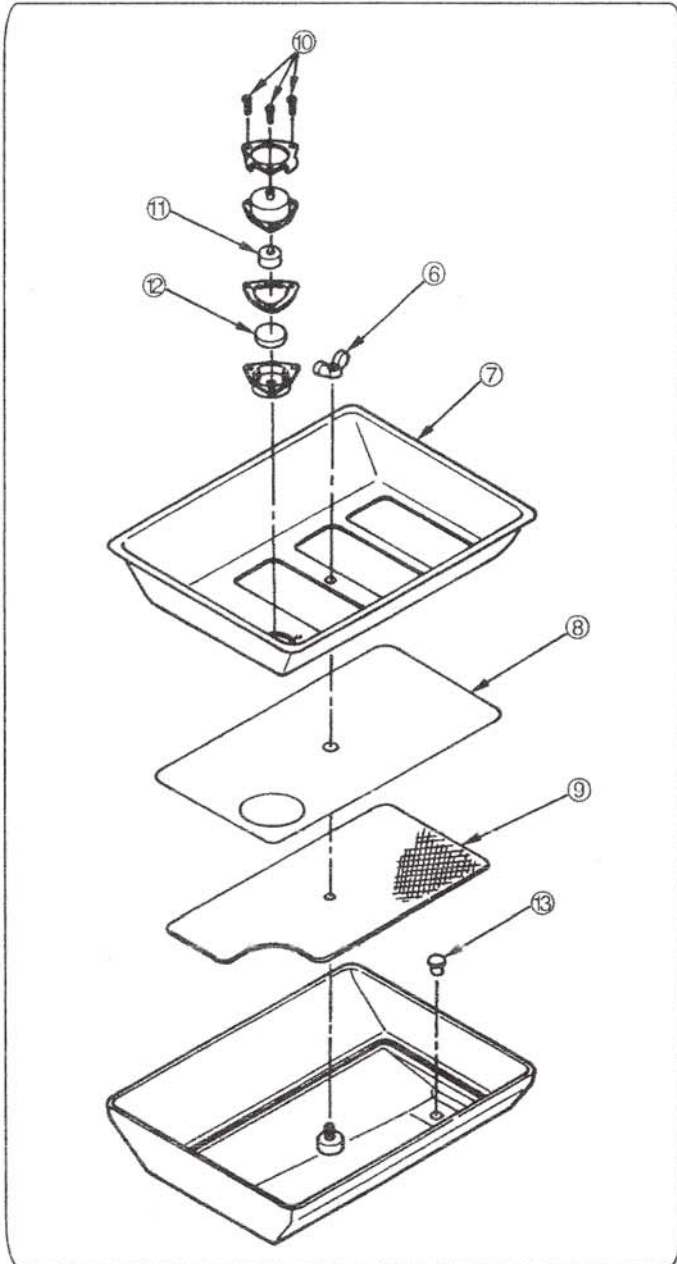

■ Cleaning the oil tank

1. Remove the oil pipe from oil tank ①.
2. Remove butterfly nut ⑥ and take out cover(upper) ⑦, filter ⑧ and cover(lower) ⑨ to clean the oil tank.
3. Remove filter case setscrews ⑩, and clean filter element ⑪ located on the inside of the filter case and magnet ⑫.

**(Caution)** Approximately once a month, clean the oil tank and the filter case.

If the filter is clogged with soil, lubrication fails resulting in trouble.

4. When replacing the oil in the oil tank, remove stopper ⑬ in the oil tank. Then, the oil can be drained from the installing port of the waste oil container in the oil pan. After draining, securely set stopper ⑬ to the oil tank. When taking out the oil tank, take it out after draining the oil.
5. Fix the filter case in which filter element ⑪ and magnet ⑫ are placed to cover (upper) ⑦ with setscrews ⑩.
6. Place cover (lower) ⑨, filter ⑧ and cover (upper) ⑦ in order in the oil tank, and fix them with butterfly nut ⑥.
7. Insert the oil pipe into the oil tank and fix it with a clip. Fill the oil tank with New Défrix Oil No. 2 up to HIGH level.

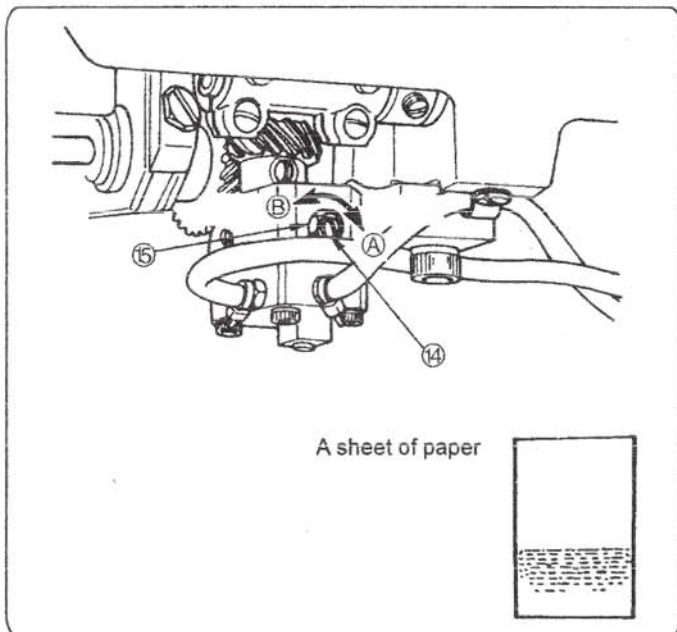

- 8) Loosen nut ⑮ and turn oil amount adjustment screw ⑭ to adjust the amount of oil in the hook.

Turning the screw clockwise **(A)** will decrease the amount of oil in the hook or counterclockwise **(B)** will increase it.

- 9) The appropriate amount of oil, when a sheet of paper is placed near the periphery of the hook, is to such an extent that splashes of oil from the hook appear in approximately five seconds as shown in the figure on the left.

## 8. ATTACHING THE NEEDLE



### WARNING:

To avoid possible personal injury due to abrupt start of the machine, turn off the power to the machine and check to be sure that the motor has totally stopped rotating in prior.

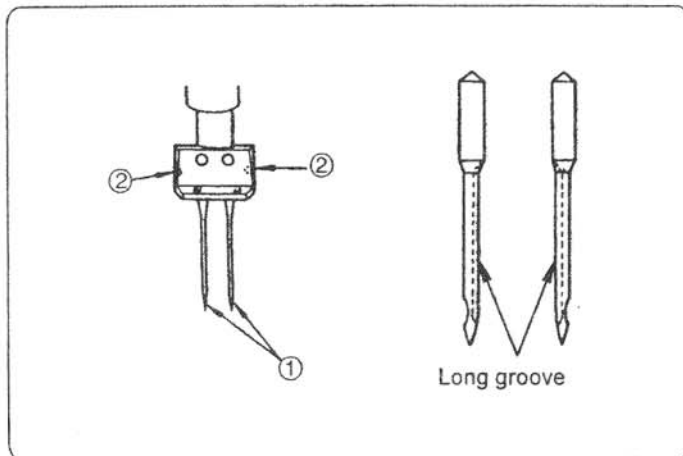

- 1) Turn the handwheel to bring the needle bar to the highest position of its stroke.
- 2) Loosen needle clamp screws ②, and hold needles ① so that the long grooves in the needles come inside respectively.
- 3) Push needles ① deep into the needle clamp holes until they will go no further.
- 4) Tighten needle clamp screws ② firmly.

**(Caution)** When replacing the needle, check the clearance provided between the needle and the blade point of hook. (Refer to "19. NEEDLE-TO-HOOK RELATION" and "20. ADJUSTING THE HOOK NEEDLE GUARD" .)

If there is no clearance, the needle and the hook will be damaged.

## 9. ATTACHING AND REMOVING THE BOBBIN



### WARNING:

To avoid possible personal injury due to abrupt start of the machine, turn off the power to the machine and check to be sure that the motor has totally stopped rotating in prior.

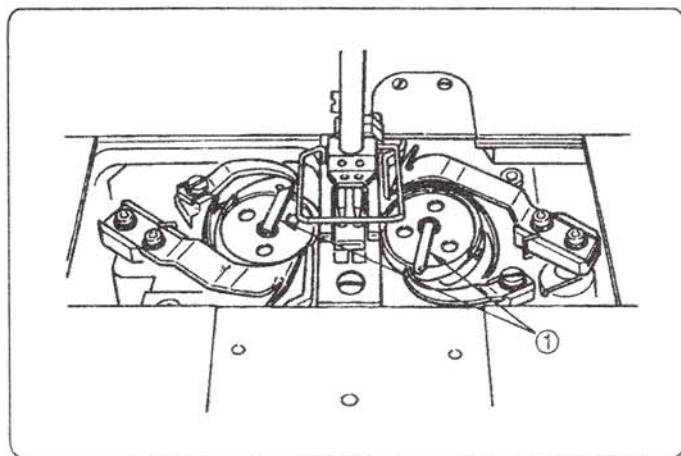

- 1) Lift latch ① of hook, and take out the bobbin.
- 2) Put the bobbin into the shaft in the hook correctly and release the latch.

**(Caution)** 1. Do not make the machine run idle with the bobbin (bobbin thread). The bobbin thread is caught in the hook. As a result, the hook may be damaged.

2. Be careful so as not to get hurt with the top end of the counter knife.

## 10. THREADING THE HOOK



### WARNING:

To avoid possible personal injury due to abrupt start of the machine, turn off the power to the machine and check to be sure that the motor has totally stopped rotating in prior.

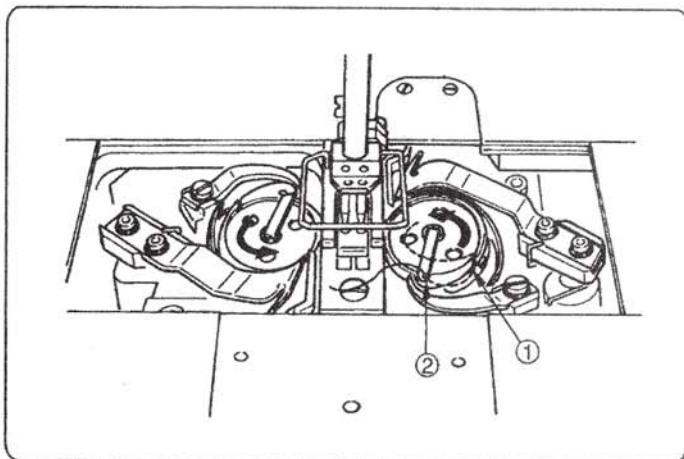

- 1) Pass the thread through thread path ① in the hook and thread hole ② in the lever, and draw the thread. Now, the thread will be brought to thread hole ② via the tension spring.
- 2) Make sure that the bobbin revolves in the direction of the arrow when you draw the thread.

## 11. INSTALLING THE BOBBIN WINDER THREAD GUIDE

1560N  
1561N

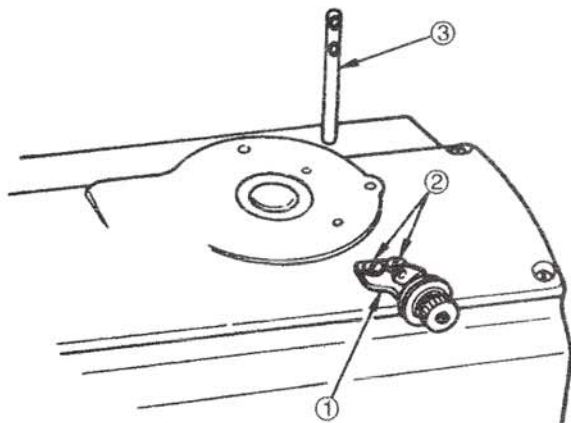

1560N-7  
1561N-7

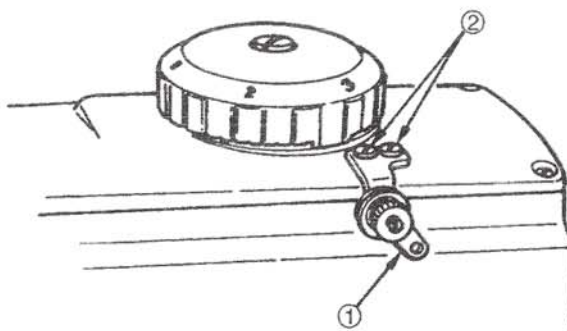

- 1) Attach bobbin winder thread guide ① to the top cover using screws ②.  
For the 1560N and 1561N attach the thread guide so that it is facing to the upper left, and for the 1560N-7 and 1561N-7 it is facing to the lower right.
- 2) Adjust the position of the thread guide referring to "12.WINDING A BOBBIN".
- 3) For the 1560N and 1561N strike bobbin thread guide rod ③ into the machine arm.

## 12. WINDING A BOBBIN

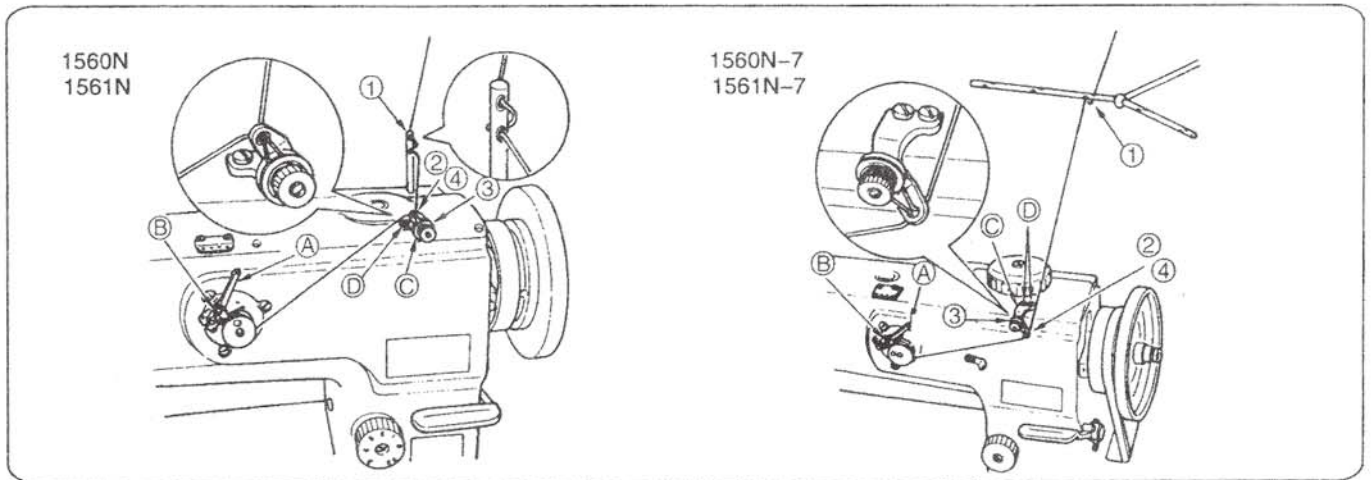

- 1) Pass the thread in the order of ①, through ④.  
Then, wind it several turns round the bobbin.
- 2) Tilt bobbin winder lever (A) .
- 3) Loosen setscrew (B) and adjust the position of the adjusting plate to wind a bobbin about 80% of its capacity.
- 4) If the bobbin is wound unevenly, correct it by moving bobbin winder thread guide (C) back or forth.  
Then, tighten setscrews (D) .
- 5) When the bobbin is filled up, the bobbin winder lever automatically releases the bobbin and the bobbin winder stops running.

## 13. THREADING THE MACHINE HEAD



### WARNING:

To avoid possible personal injury due to abrupt start of the machine, turn off the power to the machine and check to be sure that the motor has totally stopped rotating in prior.

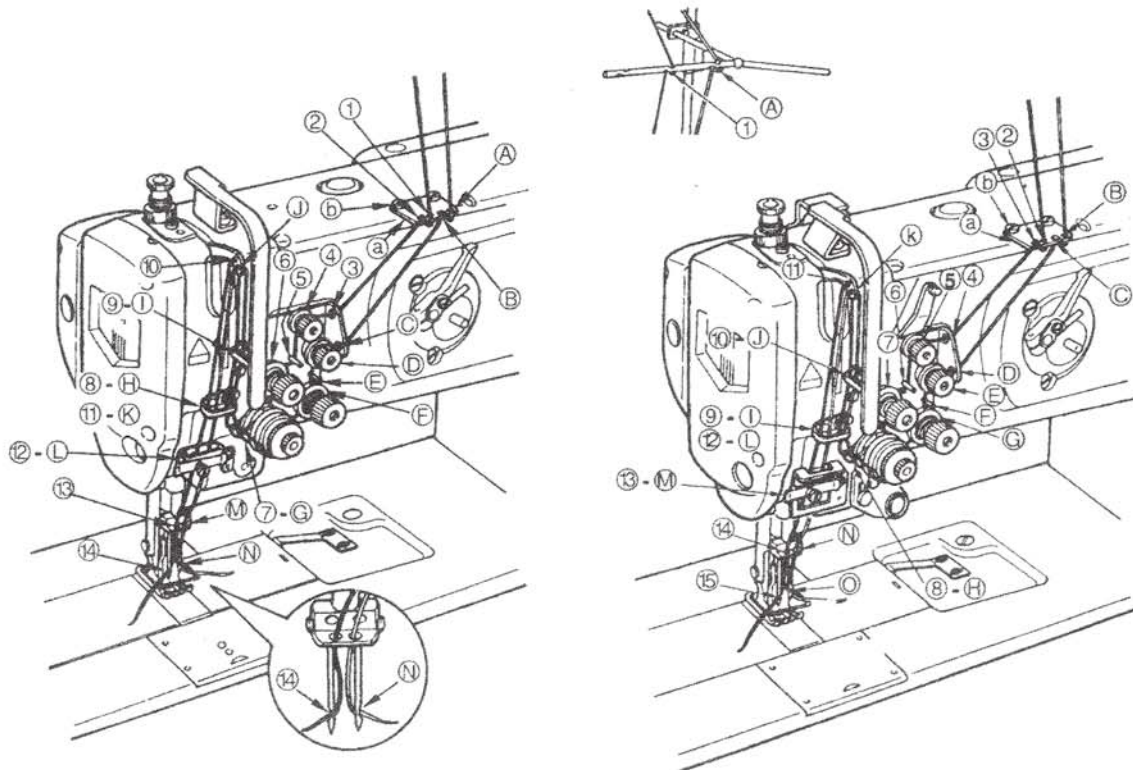

1. Attach arm thread guide (a) to the top cover with setscrew (b) .
2. Pass the left-hand needle thread in the order of ① to ⑭(⑮) .  
Pass the right-hand needle thread in the order of (A) to (N) (O) as illustrated in the figure.

## 14. ADJUSTING THE STITCH LENGTH

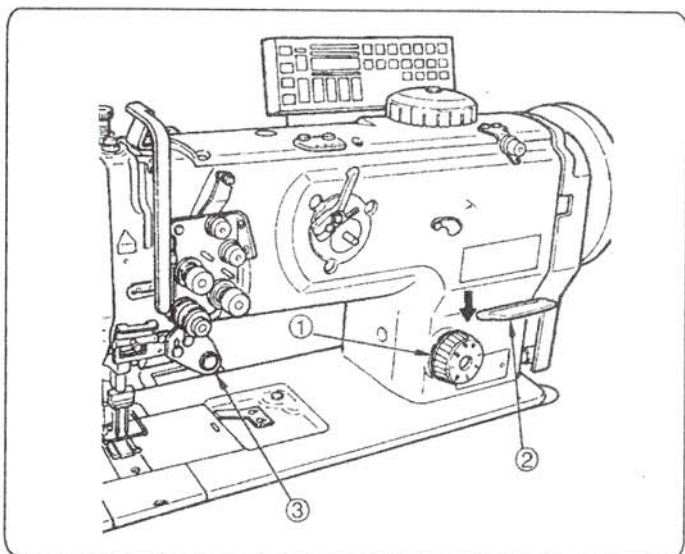

Turn stitch dial ① counterclockwise (clockwise) so that the number corresponding to the desired stitch length is brought to the top until the marking spot is reached.

### (1) Reverse feed stitching

- 1) Press down reverse feed control lever ②.
- 2) Reverse feed stitches are made as long as you keep pressing the lever down.
- 3) Release the lever, and the machine will run in the normal feed direction.

### (2) Manual one-touch reverse feed stitching (1560N-7, 1561N-7)

- 1) Press touch-back switch ③.
- 2) Reverse feed stitches are made as long as you keep pressing the lever down.
- 3) Release the switch, and the machine will run in the normal feed direction.

## 15. THREAD TENSION

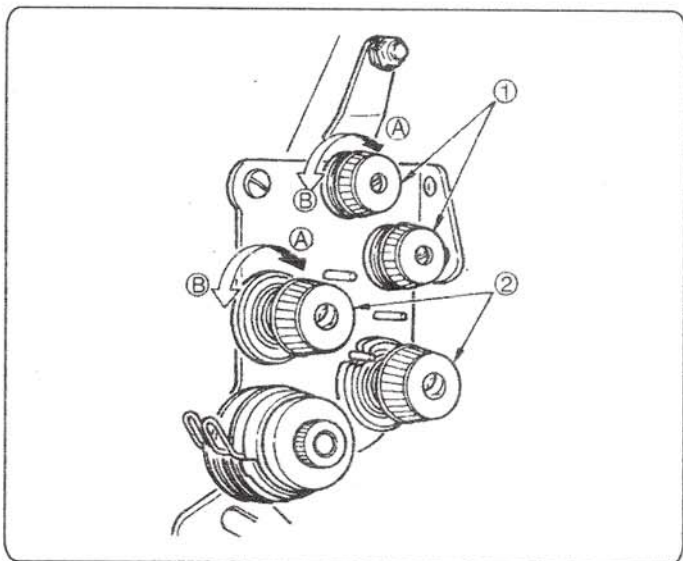

### (1) Adjusting the needle thread tension

- 1) Turn thread tension nut No.1 ① clockwise (A) to shorten the length of thread remaining on the top of needle after thread trimming. Turn the nut counterclockwise (B) to lengthen it.
- 2) Turn thread tension nut No.2 ② clockwise (A) to increase the needle thread tension, or counterclockwise (B) to decrease it.



### WARNING:

To avoid possible personal injury due to abrupt start of the machine, turn off the power to the machine and check to be sure that the motor has totally stopped rotating in prior.

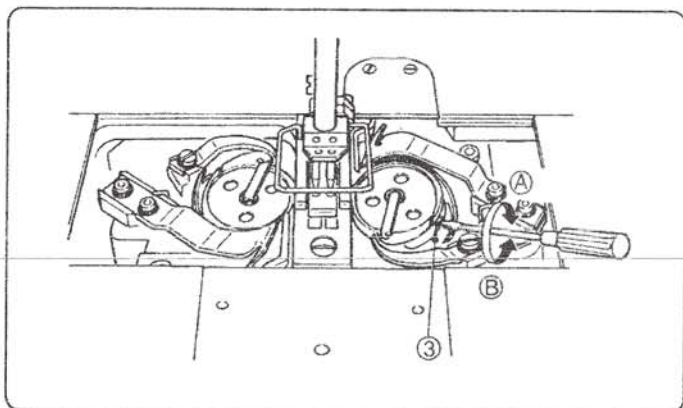

### (2) Adjusting the bobbin thread tension

Turn tension adjustment screw ③ clockwise (A) to increase the bobbin thread tension, or counterclockwise (B) to decrease it.



## 16. THREAD TAKE-UP SPRING

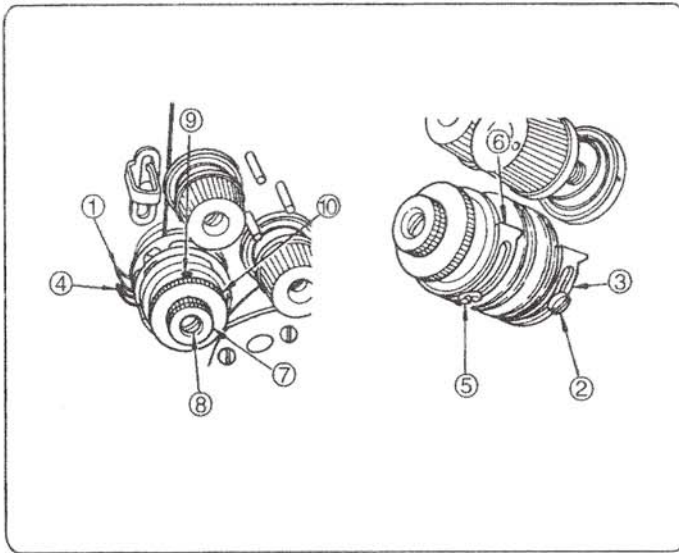

- (1) To change the stroke of the thread take-up spring
- 1) For thread take-up spring ① on the left-hand side, loosen stopper screw ② and move stopper ③ to the right or left.
  - 2) For thread take-up spring ④ on the right-hand side, loosen stopper screw ⑤ and move stopper ⑥ to the right or left.
  - 3) Move the stopper to the right to increase the stroke or to the left to decrease it.
- (2) To change the tension of the thread take-up spring
- 1) For the thread take-up spring on the left-hand side, loosen nut ⑦ and turn spring shaft ⑧ counterclockwise to increase the tension of the thread take-up spring or clockwise to decrease it.
  - 2) For the thread take-up spring on the right-hand side, loosen screw ⑨ and turn thread take-up spring peg ⑩ counterclockwise to increase the tension of the thread take-up spring or clockwise to decrease it.

## 17. HAND LIFTER

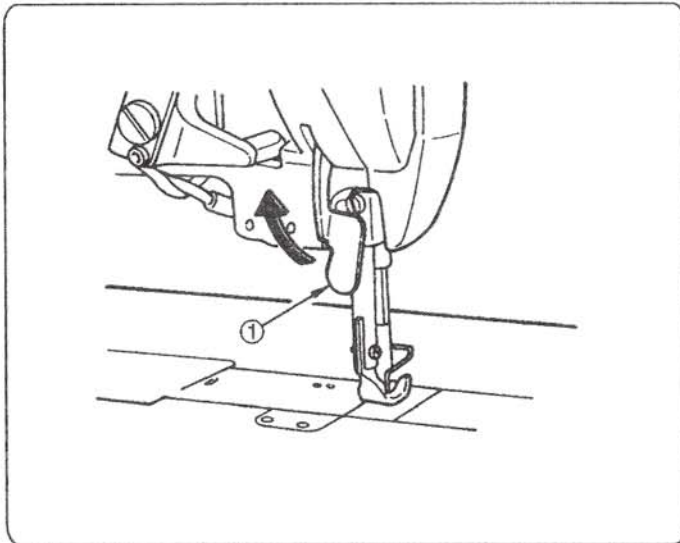

- 1) When you want to keep the presser foot in the lifted position, lift hand lifter ① in the direction of the arrow. This makes the presser foot rise 9 mm and stay at that position.
- 2) To make the presser foot come down to its home position, lower the hand lifter.

## 18. ADJUSTING THE PRESSURE OF THE PRESSER FOOT

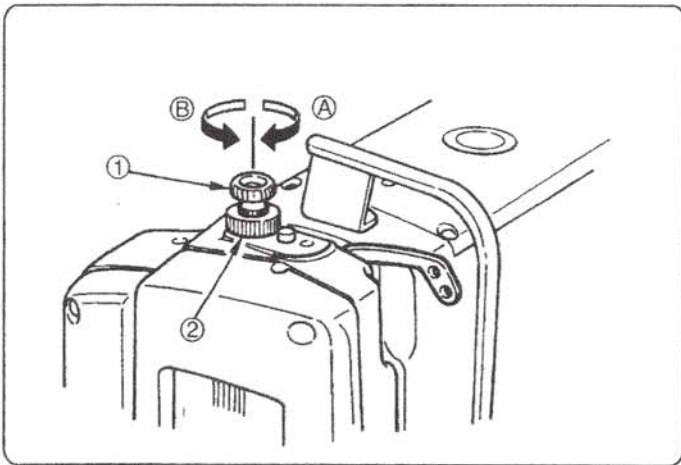

- 1) Turn presser spring regulating dial ① clockwise ① to increase the pressure of the presser foot, or counterclockwise ② to decrease it.

After the adjustment, tighten nut ②.

**(Note)** Be sure to operate the sewing machine with the pressure of the presser foot minimized as long as the presser foot securely holds the material,

## 19. NEEDLE-TO-HOOK RELATION



### WARNING:

To avoid possible personal injury due to abrupt start of the machine, turn off the power to the machine and check to be sure that the motor has totally stopped rotating in prior.

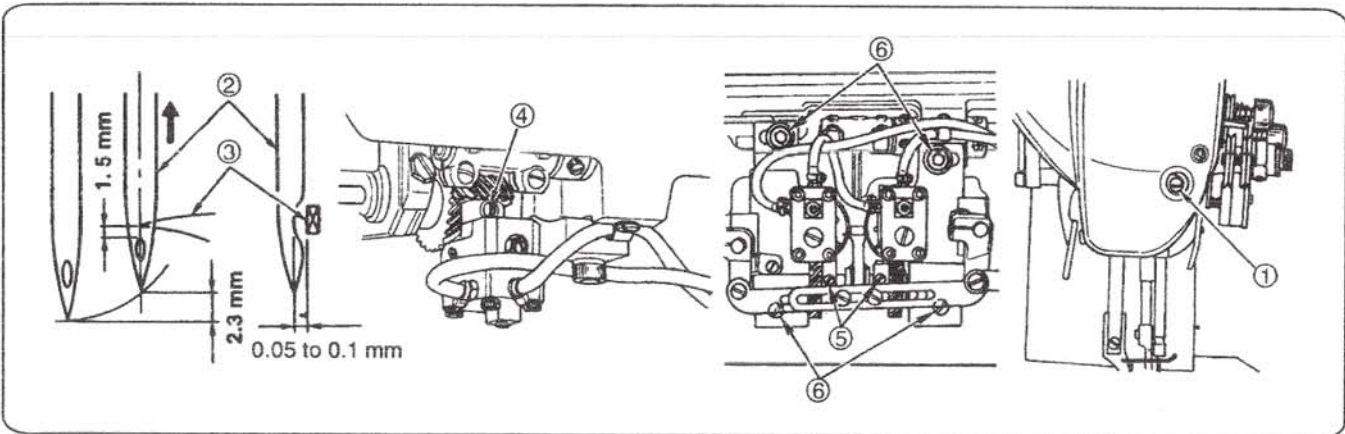

- 1) Set the stitch dial to 0 [zero].
- 2) Turn the handwheel and loosen setscrew ① in the needle bar connection to adjust so that a clearance of 1.5 mm is provided between the top end of the needle eyelet of needle ② and blade point ③ of the hook when the needle bar is raised by 2.3 mm from the lowest position of its stroke. Then, tighten the screw again.
- 3) Loosen four setscrews ⑤ in the screw gear (large) and turn the handwheel to make the needle bar ascend by 2.3 mm from the lowest position of its stroke.
- 4) Loosen setscrews ⑥ in the hook driving shaft saddle and move the hook driving shaft saddle to the right or left until a clearance of 0.05 to 0.1 mm is provided between the blade point of the hook and the needle at the position where blade point ③ of the hook is almost aligned with the center of needle ②.  
After the adjustment, tighten setscrews ⑥.
- 5) Move the screw gear (large) to the right or left until blade point ③ of the hook is aligned with the center of needle ② and tighten four setscrews ⑤. However, fit the setscrew No.1 of setscrews ⑤ to the flat section of the hook driving shaft and tighten it.

**(Note)** When replacing the hook, tighten four setscrews ④ in the screw gear (small) first. However, fit the setscrew No.1 which is "V" shaped at the top end of setscrews ④ to the "V" groove in the hook shaft and tighten it.

## 20. ADJUSTING THE HOOK NEEDLE GUARD

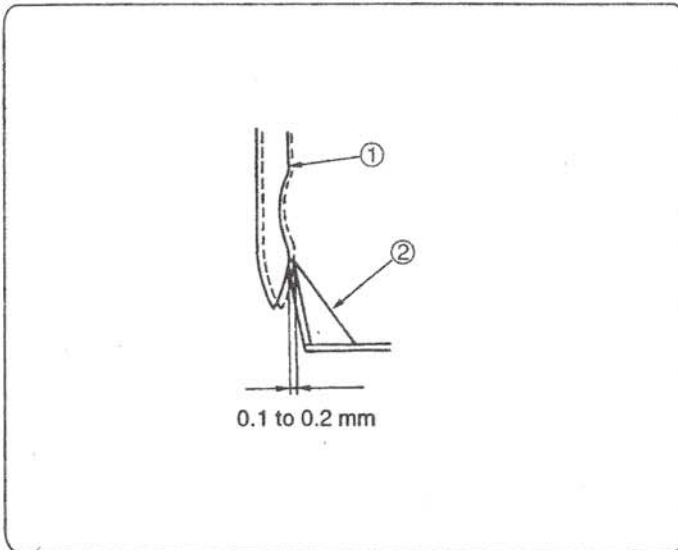

When a hook has been replaced, be sure to check the position of the hook needle guard.

As the standard position of the hook needle guard, hook needle guard (2) must push the side face of needle (1) to lean the needle by 0.1 to 0.2 mm away from its straight position.

If not, adjust the hook needle guard by bending it.

- 1) To bend the hook needle guard inward, apply a screwdriver to the outside of the hook needle guard.
- 2) To bend the hook needle guard outward, apply a screwdriver to the inside of the hook needle guard.

## 21. ADJUSTING THE BOBBIN CASE OPENING LEVER



### WARNING:

To avoid possible personal injury due to abrupt start of the machine, turn off the power to the machine and check to be sure that the motor has totally stopped rotating in prior.

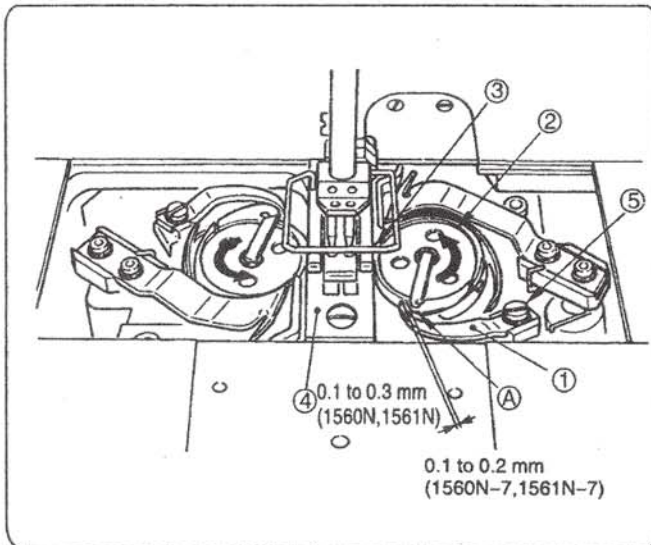

- 1) Turn the handwheel in its normal rotational direction to bring bobbin case opening lever (1) to its back end position.
- 2) Turn bobbin case (2) in the direction of the arrow until bobbin case stopper (3) rests in the groove in throat plate (4).
- 3) Loosen screw (5) in the bobbin case opening lever and adjust so that a clearance of 0.1 to 0.2 mm (1560N-7, 1561N-7), 0.1 to 0.3mm (1560N, 1561N) is provided between the bobbin case opening lever and protruding section (A) of the bobbin case.

## 22. POSITION OF THE COUNTER KNIFE AND ADJUSTMENT OF THE KNIFE PRESSURE(1560N-7,1561N-7)



### WARNING:

To avoid possible personal injury due to abrupt start of the machine, turn off the power to the machine and check to be sure that the motor has totally stopped rotating in prior.

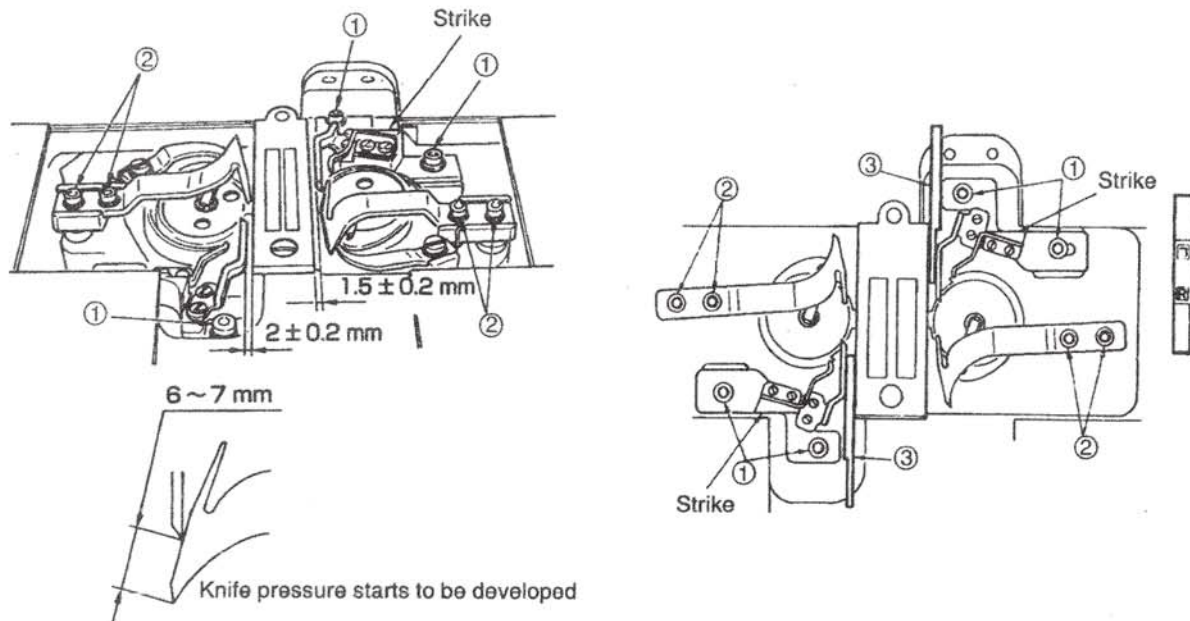

1) Move the moving knife by hand to its forward travel end.

- Adjusting the counter knife

2) Loosen setscrews ① in the counter knife bases, and adjust the positions of the counter knives so that the top end of the right-hand counter knife is  $1.5 \pm 0.2$  mm away from the end face of the throat plate and the top end of the left-hand counter knife is  $2 \pm 0.2$  mm away from the end face of the throat plate in the lateral direction and so that the counter knife bases are struck against the difference in step of the hook shaft bases in the longitudinal direction. Then, tighten setscrews ①. Use counter knife gauge ③ supplied with the machine as standard.

Use the face R of the counter knife ③ gauge for the right-hand counter knife and the face L for the left-hand one.

- Adjusting the knife pressure

3) Loosen setscrews ② in the moving knife. Turn the handwheel to move the moving knife and adjust the knife pressure.

In the standard state, the knife pressure is developed from the position where the top end of the moving knife is spaced 6 to 7 mm from the top end of the counter knife.

**(Caution)** Adjust the knife pressure in the state that the clamp spring does not come in contact with the moving knife (the clamp pressure is not developed).

## 23. ADJUSTING THE LIFTING AMOUNT OF THE PRESSER FOOT AND THE WALKING FOOT



### WARNING:

To avoid possible personal injury due to abrupt start of the machine, turn off the power to the machine and check to be sure that the motor has totally stopped rotating in prior.

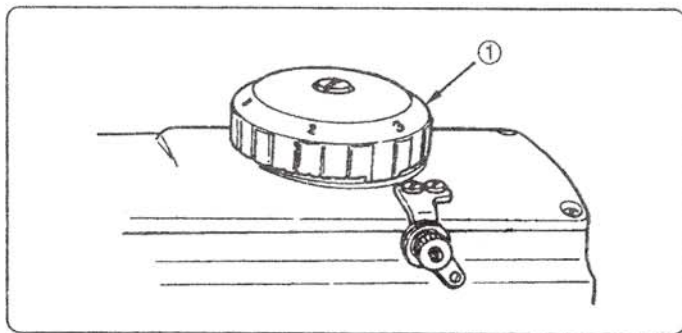

The lifting amount of the presser foot and the walking foot is adjusted using dial ①. Turn the dial clockwise to increase the lifting amount or counterclockwise to decrease it.

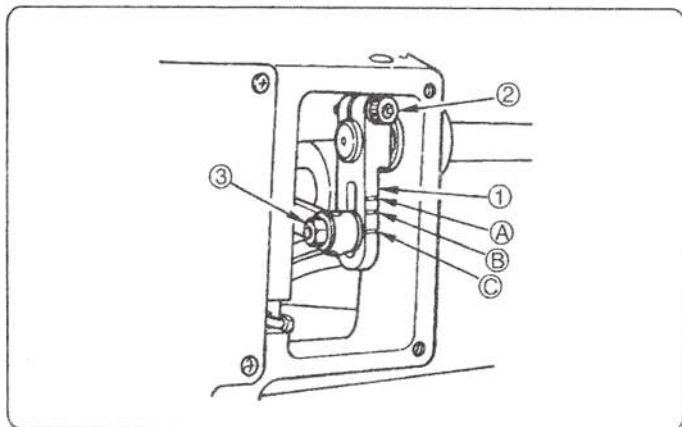

The amount of alternate vertical movement of the presser foot and the walking foot is normally equal. To increase the amount of alternate vertical movement, move upper feed arm ① upward in the range of the slot.

To decrease it, move the upper feed arm downward. Then, tighten the nut ③

To change the lifting amount of the presser foot and that of the walking foot, loosen screw ② in the upper feed arm, turn the handwheel to this side and tighten screw ② when the bottom faces of the presser foot and the walking foot are flush at the top surface of the throat plate.

Then, the lifting amount of the presser foot becomes more than that of the walking foot. Or, turn the handwheel in the reverse direction to increase the lifting amount of the walking foot more than that of the presser foot.

Standard of the amount of alternate vertical movement	
Engraved marker line (A)	Approx. 5 mm
Engraved marker line (B)	Approx. 4 mm
Engraved marker line (C)	Approx. 3 mm

## 24. SEWING SPEED TABLE

The maximum sewing speed has been specified in accordance with sewing conditions as shown in the table below.

Set the maximum sewing speed appropriately in accordance with the sewing conditions given taking care not to exceed the corresponding specified value.

1) Maximum sewing speed in accordance with the amount of alternate vertical movement of the walking foot and presser foot.

• 1560N, 1561N

Amount of alternate vertical movement of the walking foot and presser foot	Stitch length: 6 mm or less	Stitch length: More than 6 mm and 9 mm or less
Less than 3 mm	2500 rpm	2000 rpm
3 mm to less than 4 mm	2000 rpm	2000 rpm
4 mm to less than 6.5 mm	1600 rpm	1600 rpm

• 1560N-7, 1561N-7

Amount of alternate vertical movement of the walking foot and presser foot	Stitch length: 6 mm or less	Stitch length: More than 6 mm and 9 mm or less
Less than 2.5 mm	2500 rpm	1800 rpm
2.5 mm to less than 4 mm	2200 rpm	1800 rpm
3 mm to less than 4 mm	1800 rpm	1800 rpm
4 mm to less than 6.5 mm	1600 rpm	1600 rpm

2) Maximum sewing speed in accordance with the needle gauge

• 1560N,1560N-7

Needle gauge	Max. sewing speed
3.2 mm (1/8) to 9.5 mm (3/8)	2500 rpm
12.7 mm (1/2) to 19.1 mm (3/4)	2000 rpm
22.2 mm (7/8) to 31.8 mm(1-1/4)	1600 rpm

• 1561N,1561N-7

Needle gauge	Max. sewing speed
4 mm to 10 mm	2500 rpm
12 mm to 20 mm	2000 rpm
22 mm to 30 mm	1600 rpm

## 25. MOTOR PULLEY AND V BELT

Use an M type V belt.

The following table shows the relationship among the motor pulley, belt length and the rotational speed of the sewing machine.

Model	Rotational speed of sewing machine	Effective diameter of handwheel	Number of poles	Frequency	Rotational speed of motor	Effective diameter of motor pulley	Size of V belt
1560N 1561N	2500 rpm	φ 93.3mm	2	50 Hz	2840 rpm	φ 80	M 44
				60 Hz	3400 rpm	φ 65	M 43
			4	50 Hz	1430 rpm	φ 160	M 47
				60 Hz	1715 rpm	φ 135	M 46

For the motor, use a 2P or 4P clutch motor of 3-phase 400W (1/2 HP)

## 26. RESETTING THE SAFETY CLUTCH



**WARNING:**

To avoid possible personal injury due to abrupt start of the machine, turn off the power to the machine and check to be sure that the motor has totally stopped rotating in prior.

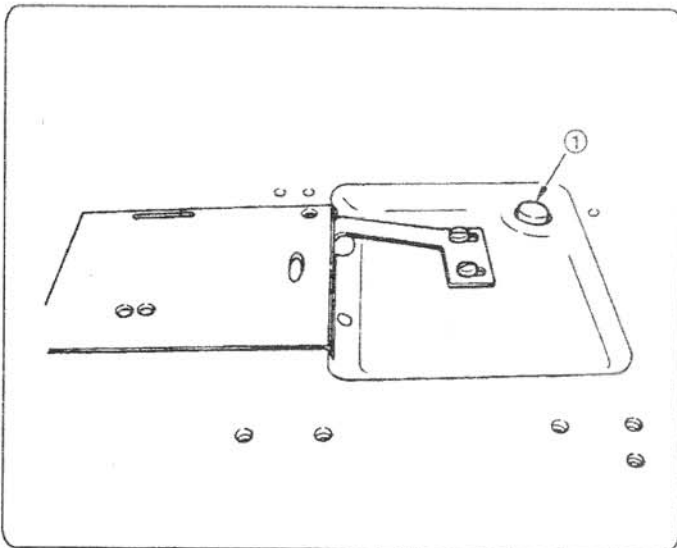

The safety clutch functions when an excessive load is applied to the hook or the other components during sewing. At this time, the hook will never rotate even if turning the handwheel.

When the safety clutch has functioned, remove the cause and reset the safety clutch as given in the following procedure.

- 1) Pressing push button ① located on the top surface of the machine bed, strongly turn the handwheel in the reverse direction of rotation.
- 2) The resetting procedure completes when the handwheel clicks.

## 27. ADJUSTING THE AUTOMATIC PRESSER FOOT LIFTER



### WARNING:

To avoid possible personal injury due to abrupt start of the machine, turn off the power to the machine and check to be sure that the motor has totally stopped rotating in prior.

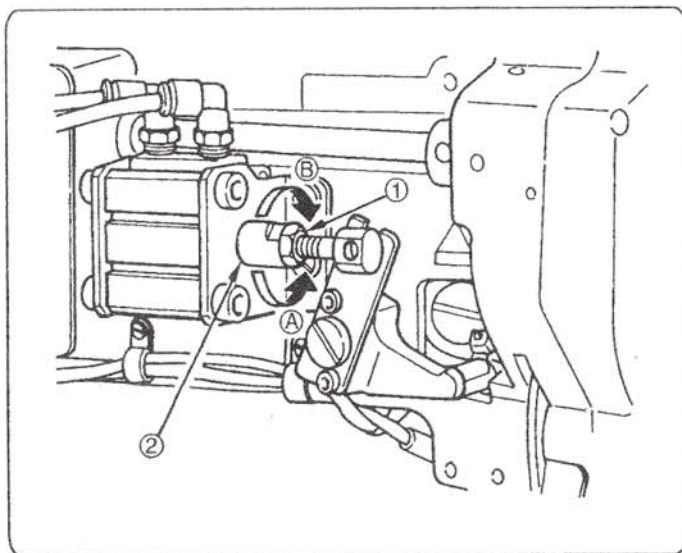

- 1) Loosen adjustment nut ①, turn cylinder rod ② and adjust so that the lifting amount of the presser foot is 16 mm when the cylinder is fully compressed.  
Turn the rod in the direction of (A) to decrease the lifting amount, or turn it in the direction of (B) to increase the lifting amount.
- 2) After the adjustment, tighten adjustment nut ①.

## 28. TROUBLES IN SEWING AND CORRECTIVE MEASURES

Troubles	Causes	Corrective measures
<p>1. Thread breakage ( Thread frays or is worn out. )</p> <p>(Needle thread trails 2 to 3 cm from the wrong side of the fabric)</p>	<p>①Thread path, needle point, hook blade point or bobbin case resting groove on the throat plate has sharp edges or burrs.</p> <p>②Needle thread tension is too high.</p> <p>③Bobbin case opening lever provides an excessive clearance at the bobbin case.</p> <p>④Needle comes in contact with the blade point of hook.</p> <p>⑤Amount of oil in the hook is too small.</p> <p>⑥Needle thread tension is too low.</p> <p>⑦Thread take-up spring works excessively or the stroke of the spring is too small.</p> <p>⑧Timing between the needle and the hook is excessively advanced or retarded.</p>	<p>○Remove the sharp edges or burrs on the blade point of hook using a fine emery paper. Buff up the bobbin case resting groove on the throat plate.</p> <p>○Decrease the needle thread tension.</p> <p>○Decrease the clearance provided between the bobbin case opening lever and the bobbin. Refer to "21. ADJUSTING THE BOBBIN CASE OPENING LEVER" .</p> <p>○Refer to "19. NEEDLE-TO-HOOK RELATION"</p> <p>○Adjust the amount of oil in the hook properly. Refer to "7. LUBRICATION" .</p> <p>○Increase the needle thread tension.</p> <p>○Decrease the tension of the spring and increase the stroke of the spring.</p> <p>○Refer to "19. NEEDLE-TO-HOOK RELATION" .</p>
2. Stitch skipping	<p>①Timing between the needle and the hook is excessively advanced or retarded.</p> <p>②Pressure of the presser foot is too low.</p> <p>③The clearance provided between the top end of the needle eyelet and the blade point of hook is not correct.</p> <p>④Hook needle guard is not functional.</p> <p>⑤Improper type of needle is used.</p>	<p>○Refer to "19. NEEDLE-TO-HOOK RELATION"</p> <p>○Tighten the presser spring regulator.</p> <p>○Refer to "19. NEEDLE-TO-HOOK RELATION"</p> <p>○Refer to "20. ADJUSTING THE HOOK NEEDLE GUARD" .</p> <p>○Replace the needle with one which is thicker than the current needle, by one count.</p>
3. Loose stitches	<p>①Bobbin thread does not pass through the tension spring of the inner hook.</p> <p>②Thread path has been poorly finished.</p> <p>③Bobbin fails to move smoothly.</p> <p>④Bobbin case opening lever provides too much clearance at the bobbin.</p> <p>⑤Bobbin thread tension is too low.</p> <p>⑥Bobbin has been wound too tightly.</p>	<p>○Thread the bobbin thread correctly.</p> <p>○Remove rough parts with a fine emery paper or buff it up.</p> <p>○Replace the bobbin or hook with a new one.</p> <p>○Refer to "21. ADJUSTING THE BOBBIN CASE OPENING LEVER" .</p> <p>○Increase the bobbin thread tension.</p> <p>○Decrease the tension applied to the bobbin winder.</p>
4. Thread slips off the needle eyelet simultaneously with thread trimming.	①Thread tension given by the tension controller No.1 is too high.	○Decrease the thread tension given by the tension controller No. 1.
5. Thread slips off the needle eyelet at the start of sewing.	<p>①Thread tension given by the tension controller No.1 is too high.</p> <p>②Clamp spring has improper shape.</p> <p>③Bobbin thread tension is too low.</p>	<p>○Decrease the thread tension given by the tension controller No. 1.</p> <p>○Replace the clamp spring with a new one or correct the current one.</p> <p>○Increase the bobbin thread tension.</p>
6. Thread is not cut sharply.	<p>①The blades of moving knife and counter knife have been improperly adjusted.</p> <p>②The knives have blunt blades.</p> <p>③Bobbin thread tension is too low.</p>	<p>○Refer to "22. POSITION OF THE COUNTER KNIFE AND ADJUSTMENT OF THE KNIFE PRESSURE" .</p> <p>○Replace the moving knife and counter knife with new ones, or correct the current ones.</p> <p>○Increase the bobbin thread tension.</p>
7. Thread remains uncut after thread trimming. (Bobbin thread trimming failure when stitch length is comparatively short.)	<p>①Initial position of the moving knife has been improperly adjusted.</p> <p>②Bobbin thread tension is too low.</p>	<p>○Refer to the Engineer's Manual.</p> <p>○Increase the bobbin thread tension.</p>
8. Thread breaks at the start of sewing after thread trimming.	①The needle thread is caught in the hook.	<p>○Shorten the length of thread remaining on the needle after thread trimming.</p> <p>Refer to "15. THREAD TENSION" .</p>



# PARTS LIST

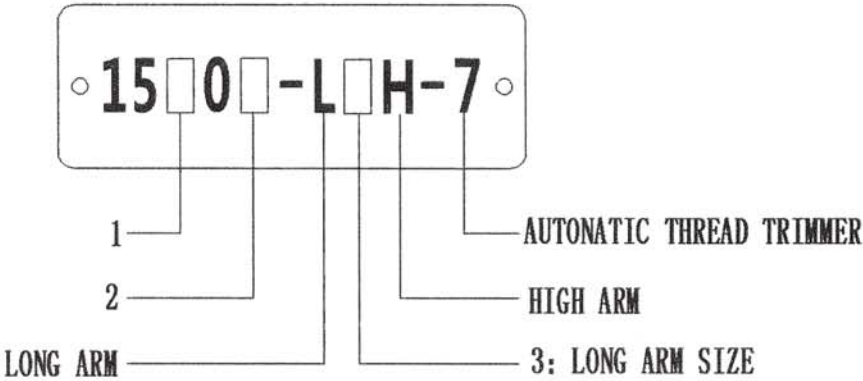

1 — { 1: SINGLE NEEDLE  
6: DOUBLE NEEDLE

2 — { N: STANARD  
D: DIRECT DRIVE

3 — { 14: LONG ARM SIZE : 14 INCHES  
18: LONG ARM SIZE : 18 INCHES  
25: LONG ARM SIZE : 25 INCHES

MARKER \* MEANS THE OPTIONS FOR GAUGGE SET OF DOUBLE NEEDLE MACHINE

# 1. FRAME & MISCELLANEOUS COVER COMPONENTS

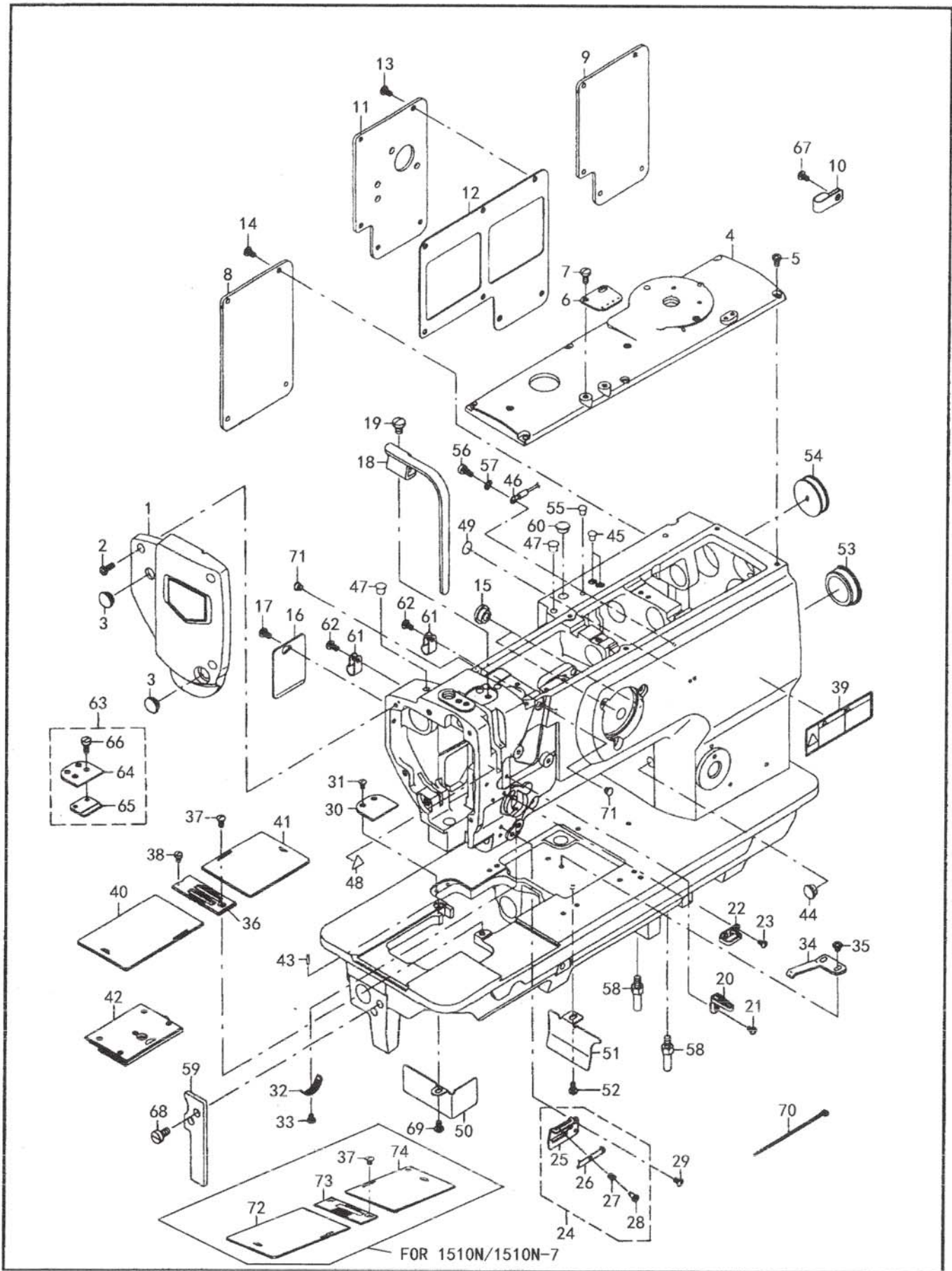

# 1. FRAME & MISCELLANEOUS COVER COMPONENTS

REF NO	PART NO	DESCRIPTION	Qty			
			1560N	1510N	1560N-7	1510N-7
1	23-0101	FACE PLATE ASM	1	1	1	1
2	23-0102	SCREW 11/64-40 L=12	3	3	3	3
3	23-0103	RUBBER PLUG D=12.5 L=4	2	2	2	2
4	23-0104	TOP COVER B	1	1	1	1
5	23-0105	SCREW 11/64-40 L=8	6	6	6	6
6	23-0106	ARM THREAD GUIDE	1	1	1	1
7	23-0107	SCREW 3/16-32 L=9.5	2	2	2	2
8	23-0108	WINDOW PLATE ASM	1	1	1	1
9	23-0112	WINDOW PLATE B	1	1		
10	23-0110	CORD HOLDER LARGE			1	1
11	39-0141	WINDOW PLATE D			1	1
12	39-0155	WINDOW PLATE PACKING C	1	1	1	1
13	23-0105	SCREW 11/64-40 L=8	5	5	5	5
14	23-0105	SCREW 11/64-40 L=8	4	4	4	4
15	23-0115	RUBBER PLUG	2	2	2	2
16	23-0116	SID COVER	1	1		
17	23-0105	SCREW 11/64-40 L=8	1	1		
18	23-0118	BALANCE COVER	1	1	1	1
19	23-0119	SCREW 15/64-28 L=9	1	1	1	1
20	23-0120	THREAD GUIDE	1	1	1	1
21	23-0121	SCREW 9/64-40 L=6	1	1	1	1
22	23-0122	FRAME THREAD GUIDE UPPER	1	1	1	1
23	23-0123	SCREW 9/64-40 L=7.2	2	2	2	2
24	23-0124	THREAD GUIDE ASM	1	1	1	1
25	23-0125	THREAD GUIDE PLATE	1	1	1	1
26	23-0126	NEER LETHREAD PRESSER PLATE	1	1	1	1
27	23-0127	THREAD PRESSER PLATE SPRING	1	1	1	1
28	23-0128	HINGE SCREW D=3.8 H=5.5	1	1	1	1
29	23-0123	SCREW 9/64-40 L=7.2	1	1	1	1
30	39-0168	AUXILIARY COVER			1	1
31	23-0123	SCREW 9/64-40 L=7.2			2	2
32	23-0132	TAKE-UP SPRING ADJUSTING PLATE	1	1	1	1
33	23-0133	SCREW 9/64-40 L=4.5	1	1	1	1
34	23-0134	BWD SLIDE SPRING	1	1	1	1
35	23-0135	SCREW 11/64-40 L=5	2	2	2	2
36	23-0136*	NEEDLE PLATE	1		1	
37	23-0137	SCREW 11/64-40 L=8.5	1	2	1	2
38	23-0138	SCREW 11/64-40 L=6	1		1	
39	23-0139	SAFETY LABEL 12	1	1	1	1
40	23-0140*	BED SLIDE (LEFT) A	1		1	
41	23-0142*	BED SLIDE (RIGHT) A	1		1	
42	23-0143	BED SLIDE ASM	1		1	
43	23-0144	THROAT PLATE PIN	1		1	
44	23-0145	RUBBER PLUG	1	1	1	1
45	23-0146	RUBBER PLUG	2	2	2	2
46	39-0147	EARTH CORD ASM		1		1
47	23-0148	RUBBER PLUG	2	2	2	2
48	23-0149	ATTENTION SEAL	1	1	1	1
49	23-0150	GROUND MARK	1	1	1	1
50	23-0151	OIL SHIELD (LEFT)	1	1	1	1

# 1. FRAME & MISCELLANEOUS COVER COMPONENTS

REF NO	PART NO	DESCRIPTION	Qty			
			1560N	1510N	1560N-7	1510N-7
51	23-0152	DUST COVER	1	1		
52	23-0105	SCREW 11/64-40 L=8	1	1		
53	23-0157	CAP	1	1	1	1
54	23-0158	RUBBER PLUG	1	1	1	1
55	23-0159	RUBBER PLUG			1	1
56	23-0170	SCREW 11/64-40 L=11			1	1
57	23-0161	TOOTHED WASHER D=5.3			1	1
58	23-0162	BED SCREW STUD	2	2	2	2
59	23-0163	BED SUPPORT PLATE	1	1	1	1
60	23-0164	RUBBER PLUG	1	1	1	1
61	23-0165	CABLE CLIP			2	2
62	23-0105	SCREW 11/64-40 L=8			2	2
63	23-0167	AUXILIARY COVER ASM	1	1		
64	23-0168	AUXILIARY COVER	1	1		
65	23-0169	SLIDING PLATE SUPPORT	1	1		
66	23-0170	SCREW 11/64-40 L=11	2	2		
67	23-0105	SCREW 11/64-40 L=8			1	1
68	23-0172	SCREW 15/64-28 L=12	2	2	2	2
69	23-0105	SCREW 11/64-40 L=8	1	1	1	1
70	23-0174	CABLE BAND			2	2
71	23-0175	CAP	2	2		
72	25-0138	BED SLIDE (LEFT) A		1		1
73	25-0136	NEEDLE PLATE		1		1
74	25-0139	BED SLIDE (RIGHT) A		1		1

## 2. UPPER SHAFT LOWER SHAFT DRIVING & BALANCE COMPONENTS

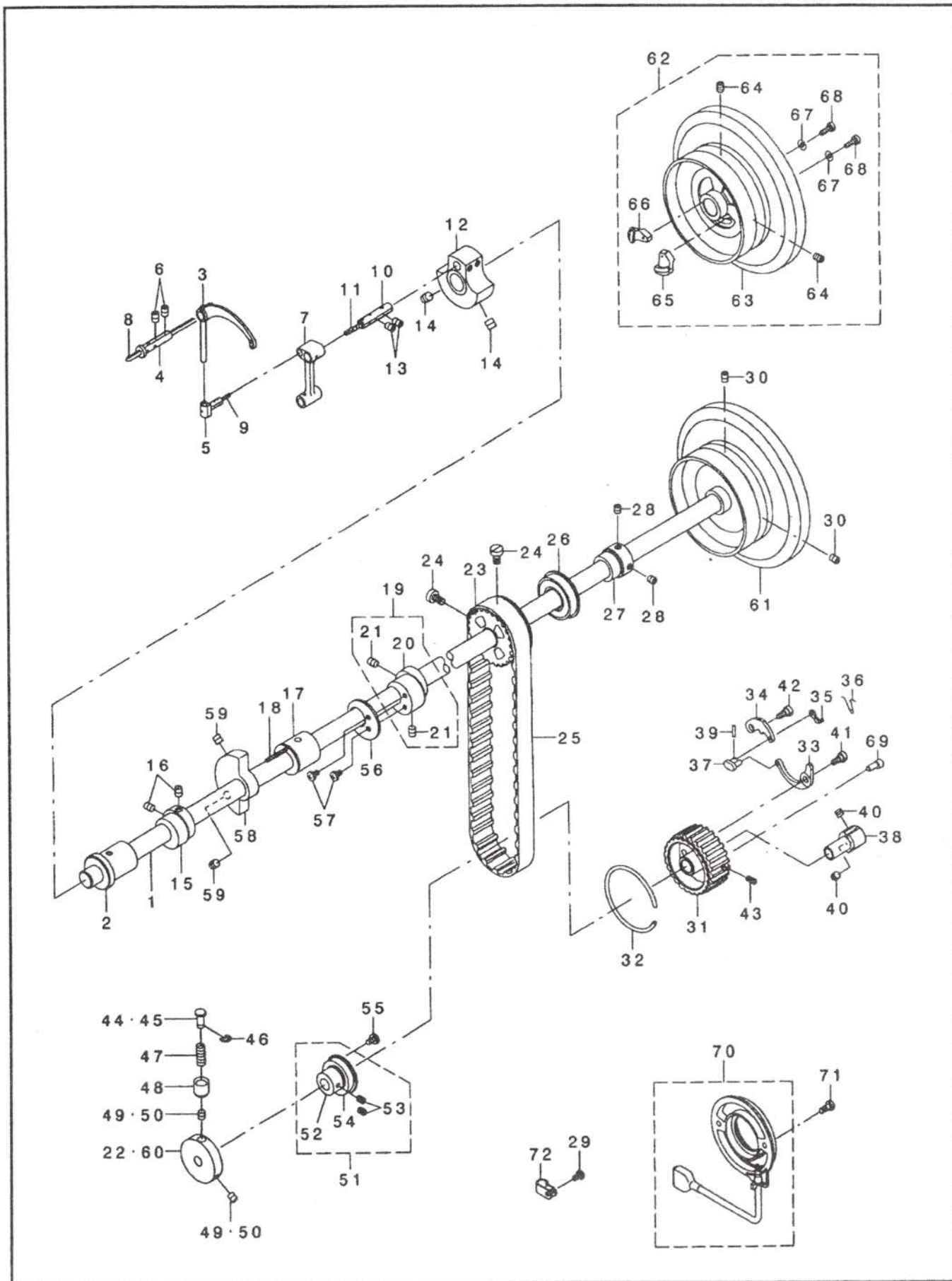

## 2. UPPER SHAFT LOWER SHAFT DRIVING & BALANCE COMPONENTS

REF NO	PART NO	DESCRIPTION	Qty			
			1560N	1510N	1560N-7	1510N-7
1	23-0201	UPPER SHAFT	1	1	1	1
2	23-0202	UPPER SHAFT FRONT METAL	1	1	1	1
3	23-0203	THREAD TAKE-UP LEVER	1	1	1	1
4	23-0204	TAKE-UP LEVER PIN	1	1	1	1
5	23-0205	THRUST PIN	1	1	1	1
6	23-0206	SCREW 15/64-28 L=8	2	2	2	2
7	23-0207	NEEDLE BAR CRANK ROD	1	1	1	1
8	23-0208	OIL WICK	1	1	1	1
9	23-0209	OIL WICK	1	1	1	1
10	23-0210	NEEDLE BAR CRANK PIN	1	1	1	1
11	23-0211	OIL WICK	1	1	1	1
12	23-0212	COUNTER WEIGHT (A) (36MM)	1	1	1	1
13	23-0206	SCREW 15/64-28 L=8	2	2	2	2
14	23-0214	SCREW M8 L=8	2	2	2	2
15	23-0215	UPPER FEED CAM	1	1	1	1
16	23-0216	SCREW 1/4-40 L=8	2	2	2	2
17	23-0217	UPPER SHAFT INNER METAL	1	1	1	1
18	23-0218	OIL WICK	1	1	1	1
19	23-0219	ECCENTRIC CAM A ASM	1	1	1	1
20	23-0220	ECCENTRIC CAM A	1	1	1	1
21	23 0216	SCREW 1/4-40 L=8	2	2	2	2
22	23-0222	SAFETY CLUTCH DISC	1	1	1	1
23	23-0223	UPPER SPROCKET	1	1	1	1
24	23-0224	SCREW 1/4-40 L=11	2	2	2	2
25	23-0225	TIMING BELT	1	1	1	1
26	23-0226	BUSHING REAR	1	1	1	1
27	23-0227	UPPER SHAFT BEARING HOOK	1	1	1	1
28	23-0228	SCREW M6 L=6	2	2	2	2
29	23-0105	SCREW 11/64-40 L=8			1	1
30	23-0206	SCREW 15/64-28 L=8	2	2		
31	23-0231	LOWER SPROCKET	1	1	1	1
32	23-0232	SPROCKET RING	1	1	1	1
33	23-0233	SAFETY CLUTCH SPRING	1	1	1	1
34	23-0234	SAFETY CLUTCH HOOK	1	1	1	1
35	23-0235	SAFETY CLUTCH COUNTER-HOOK	1	1	1	1
36	23-0236	COUNTER-HOOK SPRING	1	1	1	1
37	23-0237	SAFETY CLUTCH SMALL LINK	1	1	1	1
38	23-0238	SAEFTY BASE	1	1	1	1
39	23-0239	SAFETY CLUTCH SMALL LINK PIN	1	1	1	1
40	23-0408	SCREW 1/4-40 L=6	2	2	2	2
41	23-0241	HINGE SCREW D=6.35 H=3.2	1	1	1	1
42	23-0241	HINGE SCREW D=6.35 H=3.2	1	1	1	1
43	23-0243	SCREW 11/64-40 L=9.5	1	1	1	1
44	23-0244	SAFETY CLUTCH PUSH BUTTON	1	1		
45	39-0245	SAFETY CLUTCH PUSH BUTTON			1	1
46	23-0246	E-RING	1	1	1	1
47	23-0247	SPRING	1	1	1	1
48	23-0248	SAFETY CLUTCH KNOB EEVE	1	1	1	1
49	23-0249	SCREW 15/64-28 L=7	2	2		
50	39-0250	SCREW 1/4-40 L=4.5			2	2

## 2. UPPER SHAFT LOWER SHAFT DRIVING & BALANCE COMPONENTS

REF NO	PART NO	DESCRIPTION	Qty			
			1560N	1510N	1560N-7	1510N-7
51	23-0251	THRUST COLLAR ASM B	1	1	1	1
52	23-0252	THRUST COLLAR B	1	1	1	1
53	23-0253	SCREW 1/4-40 L=10	2	2	2	2
54	23-0254	BEARING	1	1	1	1
55	23-0255	SCREW 3/16-28 L=7	2	2	2	2
56	23-0256	HORIZONTAL FEED CAM COVER	1	1	1	1
57	23-0257	SCREW 11/64-40 L=7	2	2	2	2
58	23-0258	BALANCER	1	1		
59	23-0259	SCREW 15/64-28 L=15	2	2		
60	39-0260	SAFETY CLUTCH DISC			1	1
61	23-0261	FLYWHEEL	1	1		
62	39-0262	FLYWHEEL ASM			1	1
63	39-0263	FLYWHEEL			1	1
64	23-0206	SCREW 15/64-28 L=8			2	2
65	39-0265	MAGNET FITTING BASE A ASM			1	1
66	39-0266	MAGNET FITTING BASE B ASM			1	1
67	39-0267	WASHER			2	2
68	39-0268	SCREW 11/64-40 L=12			2	2
69	23-0269	ADJUSTING PIN	1	1	1	1
70	39-0270	CONTAIN SYNCHRO ASM	1	1	1	1
71	39-0271	SCREW			2	2
72	39-0165	CABLE CLIP			1	1

### 3. NEEDLE BAR ROCKING COMPONENTS

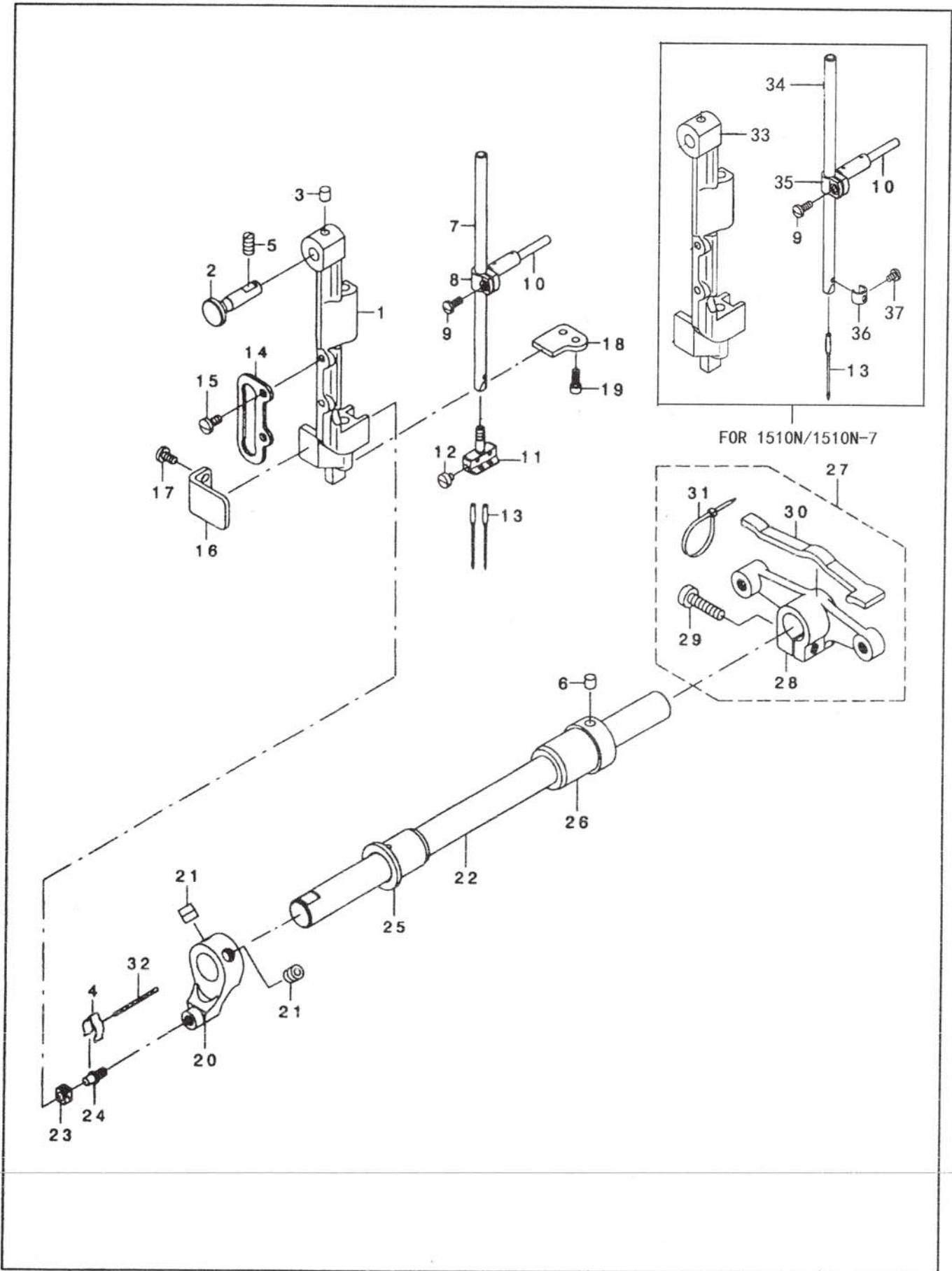



### 3. NEEDLE BAR ROCKING COMPONENTS

REF NO	PART NO	DESCRIPTION	Qty			
			1560N	1510N	1560N-7	1510N-7
1	23-0301	NEEDLE BAR FRAME	1		1	
2	23-0302	HINGE STUD	1	1	1	1
3	23-0303	FELT	1	1	1	1
4	23-0304	OIL WICK RETAINER	1	1	1	1
5	23-0305	SCREW 15/64-28 L=10.5	1	1	1	1
6	23-0306	FELT	1	1	1	1
7	23-0307	NEEDLE BAR	1		1	
8	23-0308	NEEDLE ROD HOLDER	1		1	
9	23-0309	SCREW 9/64-40 L=8.5	1	1	1	1
10	23-0310	FELT	1	1	1	1
11	23-0311*	NEEDLE CLAMP	1		1	
12	23-0312	SCREW 9/64-40 L=3.5	2		2	
13	23-0313	NEEDLE	2	1	2	1
14	23-0314	UPPER FEED BAR GUIDE	1	1	1	1
15	23-0315	SCREW 11/64-40 L=8.5	2	2	2	2
16	23-0316	ROCKING BASE GUIDE	1	1	1	1
17	23-0317	SCREW 11/64-40 L=7.5	2	2	2	2
18	23-0318	ROCKING BASE GUIDE (B)	1	1	1	1
19	23-0319	SCREW 9/64-40 L=10	2	2	2	2
20	23-0320	ROCKING FRONT ARM	1	1	1	1
21	23-0321	SCREW M8 L=8	2	2	2	2
22	23-0322	ROCKING SHAFT	1	1	1	1
23	23-0323	SQUARE BLOCK	1	1	1	1
24	23-0324	STUD	1	1	1	1
25	23-0325	ROCKING SHAFT FRONT METAL	1	1	1	1
26	23-0326	ROCKING SHAFT REAR METAL	1	1	1	1
27	23-0327	ROCKING REAR ARM ASM	1	1	1	1
28	23-0328	ROCKING REAR ARM	1	1	1	1
29	23-0329	SCREW 15/64-28 L=23.5	1	1	1	1
30	23-0330	ROCKING REAR ARM FELT	1	1	1	1
31	23-0331	CABLE BAND	2	2	2	2
32	23-0332	OIL WICK	1	1	1	1
33	25-0301	NEEDLE BAR FRAME		1		1
34	25-0307	NEEDLE BAR		1		1
35	25-0308	NEEDLE ROD HOLDER		1		1
36	25-0311	THREAD GUARD		1		1
37	25-0312	SCREW 1/8-44 L=4.5		1		1

# 4. PRESSURE ADJUSTING & UPPER FEED MECHANISM COMPONENTS

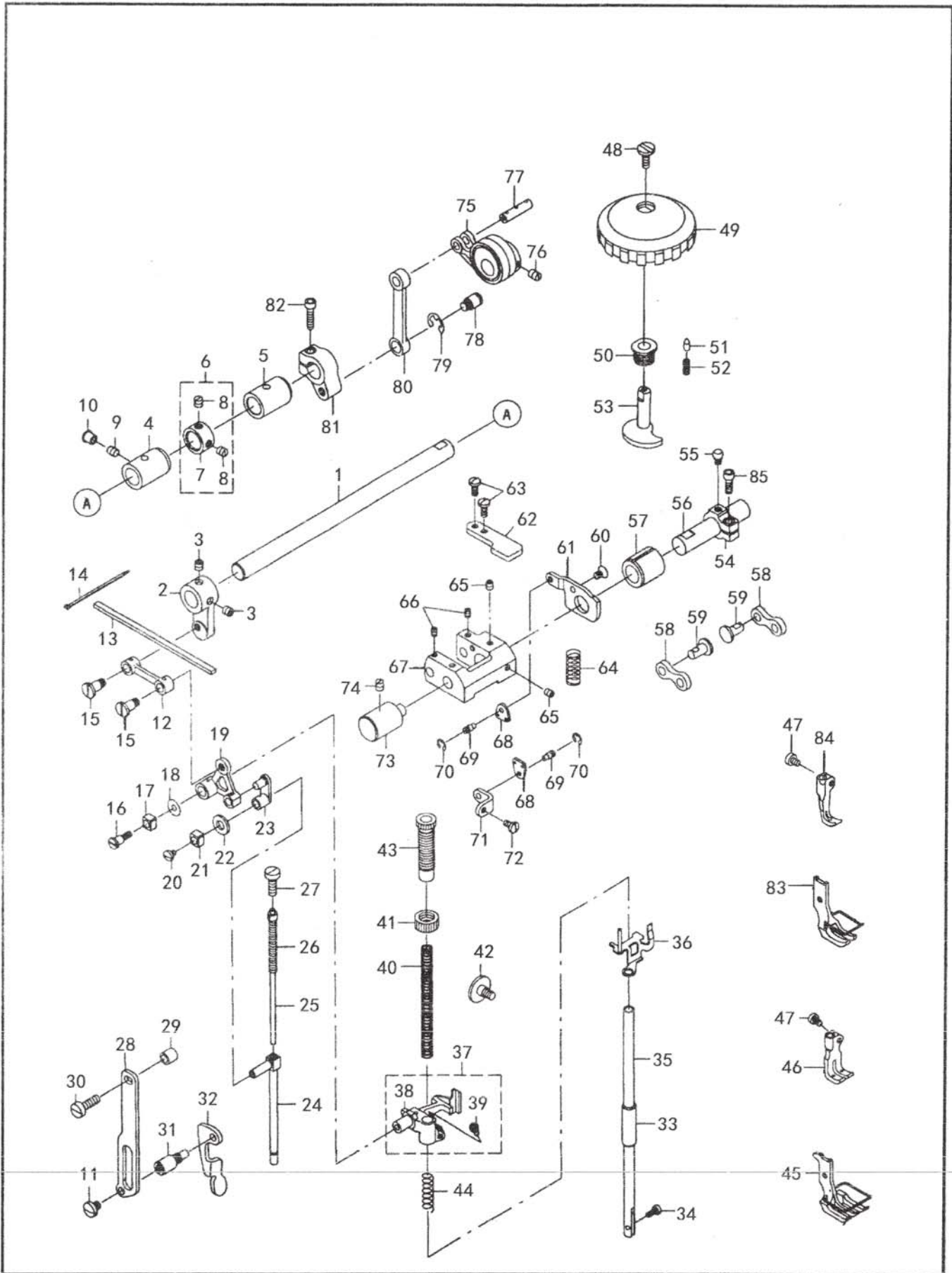

#### 4. PRESSURE ADJUSTING & UPPER FEED MECHANISM COMPONENTS

REF NO	PART NO	DESCRIPTION	Qty			
			1560N	1510N	1560N-7	1510N-7
1	23-0401	UPPER FEED SHAFT	1	1	1	1
2	23-0402	UPPER FEED FRONT ARM	1	1	1	1
3	23-0403	SCREW 1/4-40 L=6	2	2	2	2
4	23-0404	FRONT METAL	1	1	1	1
5	23-0405	FEED SHAFT METAL	1	1	1	1
6	23-0406	MAIN SHAFT THRUST COLLAR ASM	1	1	1	1
7	23-0407	MAIN SHAFT THRUST COLLAR	1	1	1	1
8	23-0403	SCREW 1/4-40 L=6	2	2	2	2
9	23-0249	SCREW 15/64-28 L=7	1	1	1	1
10	23-0148	RUBBER PLUG	1	1	1	1
11	23-0411	SCREW 15/64-28 L=7	1	1	1	1
12	23-0412	UPPER FEED LINK	1	1	1	1
13	23-0413	FELT	1	1	1	1
14	23-0174	CLIP CV-70S	2	2	2	2
15	23-0415	HINGE SCREW B	2	2	2	2
16	23-0416	HINGE SCREW D=6.35 H=7	1	1	1	1
17	23-0417	SLIDE BLOCK	1	1	1	1
18	23-0418	WASHER	1	1	1	1
19	23-0419	TRIANGULAR LEVER	1	1	1	1
20	23-0420	SCREW 11/64-40 L=5	1	1	1	1
21	23-0417	SLIDE BLOCK	1	1	1	1
22	23-0422	FELT	1	1	1	1
23	23-0423	WALKING BAR DRIVING LINK	1	1	1	1
24	23-0424	WALKING BAR	1	1	1	1
25	23-0425	WALKING BAR ASM	1	1	1	1
26	23-0426	WALKING BAR SPRING	1	1	1	1
27	23-0427	SCREW 15/64-28 L=17	1	1	1	1
28	23-0428	UPPER FEED GUIDE PLATE	1	1	1	1
29	23-0429	ROLLER	1	1	1	1
30	23-0430	SCREW 15/64-28 L=19	1	1	1	1
31	23-0449	GUIDE PLATE SPACER	1	1	1	1
32	23-0448	PRESSER LIFTER LEVER	1	1	1	1
33	23-0498	PRESSER BAR LOWER BUSHING	1	1	1	1
34	23-0450	SCREW 9/64-40 L=9	1	1	1	1
35	23-0439	PRESSER BAR	1	1	1	1
36	23-0436	HOLDING PLATE COMPL	1	1	1	1
37	23-0440	PRESSER BAB HPLDER ASM	1	1	1	1
38	23-0441	PRESSER BAB HPLDER	1	1	1	1
39	23-0315	SCREW 11/64-40 L=8.5	1	1	1	1
40	23-0444	PRESSER SPRING	1	1	1	1
41	23-0443	NUT	1	1	1	1
42	23-0445	HINGE SCREW D=8 H=4.9	1	1	1	1
43	23-0497	PRESSER ADJUSTING SCREW	1	1	1	1
44	23-0447	THREAD RELEASE SPRING	1	1	1	1
45	23-0455*	PRESSER FOOT ASM	1		1	
46	23-0451*	WALKING FOOT	1		1	
47	23-0453	SCREW 11/64-40 L=6.5	1	1	1	1
48	39-0464	SCREW 11/64-40 L=6	1	1	1	1
49	39-0458	VESTICAL DIAL	1	1	1	1
50	39-0460	VESTICAL DIAL SHAFT BUSHING	1	1	1	1

#### 4. PRESSURE ADJUSTING & UPPER FEED MECHANISM COMPONENTS

REF NO	PART NO	DESCRIPTION	Qty			
			1560N	1510N	1560N-7	1510N-7
51	39-0462	VERTICAL DIAL PIN	1	1	1	1
52	39-0463	SPRINO	1	1	1	1
53	39-0461	VERTICAL ADJUSTING CAM	1	1	1	1
54	39-0465	VERTICAL ADJUSTING ARM	1	1	1	1
55	39-0466	PIN	1	1	1	1
56	39-0468	VERTICAL CHANGE BASE SHAFT	1	1	1	1
57	39-0469	FEED SHAFT FRONT METAL	1	1	1	1
58	39-0484	CONNECTION LINK B	2	2	2	2
59	39-0485	CONNECTION LINK B SUPPORT PIN	2	2	2	2
60	39-0472	SCREW M5 L=8	1	1	1	1
61	39-0471	UPPER FEED STOPPER PLATE (A)	1	1	1	1
62	39-0473	UPPER FEED STOPPER PLATE (B)	1	1	1	1
63	23-0315	SCREW 11/64-40 L=8.5	2	2	2	2
64	39-0476	VERTICAL SHAFT SPTING	1	1	1	1
65	23-1220	SCREW M6 L=6	2	2	2	2
66	23-1220	SCREW M6 L=6	2	2	2	2
67	39-0470	VERTICAL CHANGE BELT	1	1	1	1
68	39-0475	SPRING HOOK	2	2	2	2
69	39-0477	CONNECTING ROD HINGE SCREW	2	2	2	2
70	39-0478	E-RING	2	2	2	2
71	39-0479	UPPER FEED DOG SPRING HOOK	1	1	1	1
72	23-0317	SCREW 11/64-40 L=7.5	1	1	1	1
73	23-0527	FEED ADJUSTING BASE SUPPORT	1	1	1	1
74	23-0249	SCREW 15/64-28 L=7	1	1	1	1
75	23-0481	ECCENTRIC ROD (SET)	1	1	1	1
76	23-0216	SCREW 1/4-40 L=8	2	2	2	2
77	39-0483	CONNECTION LINK PIN B	1	1	1	1
78	39-0488	HINGE SCREW	1	1	1	1
79	39-0489	E-SHAPED SNAP RING	1	1	1	1
80	39-0487	UPPER FEED LINK (B)	1	1	1	1
81	39-0490	UPPER FEED REAR ARM (B)	1	1	1	1
82	39-0491	SCREW M5 L=20	1	1	1	1
83	25-0454	PRESSER FOOT ASM		1		1
84	25-0459	WALKING FOOT		1		1
85	39-0467	SCREW M5 L=14	1	1	1	1

# 5. FEED MECHANISM COMPONENTS

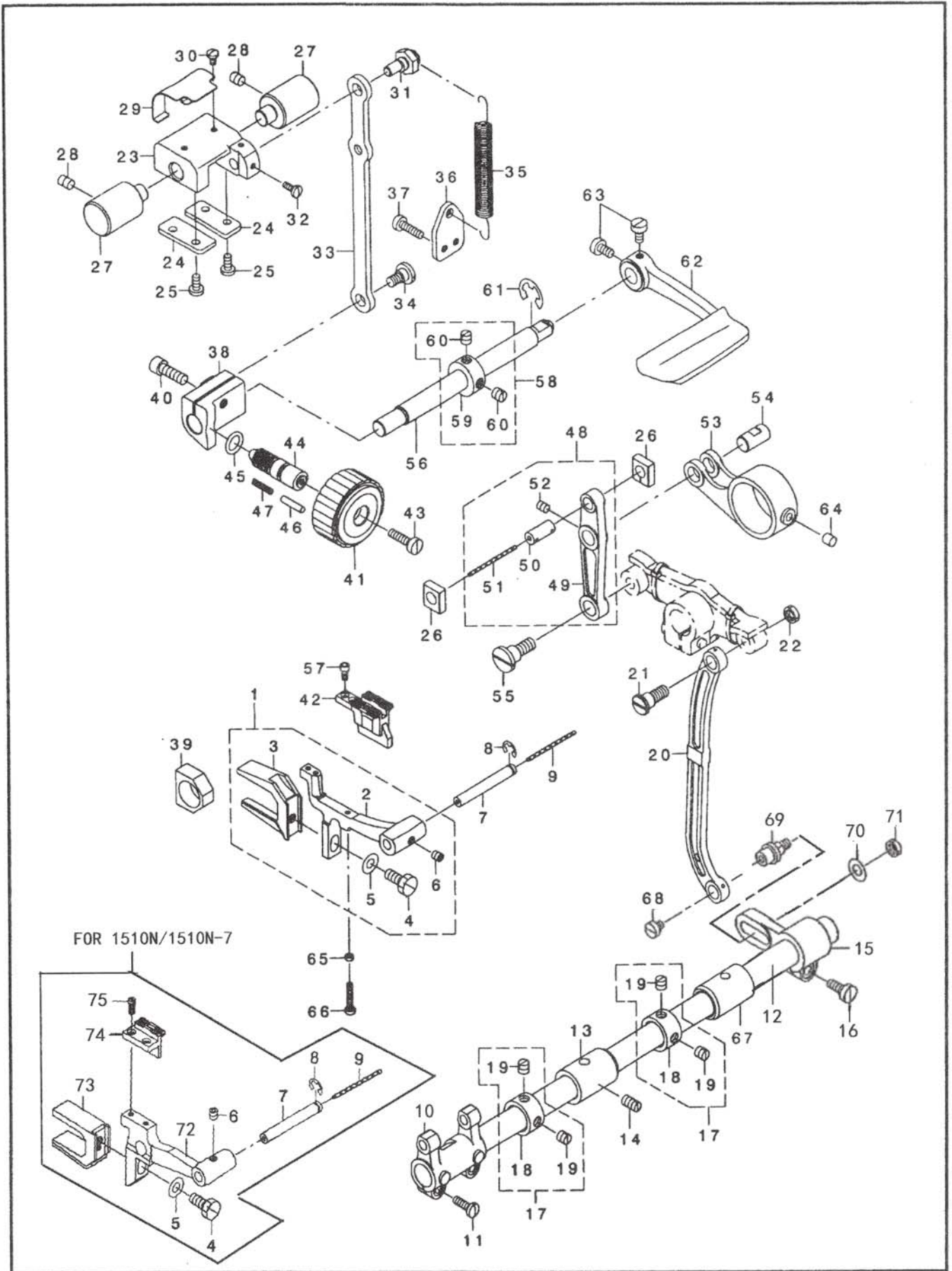

## 5. FEED MECHANISM COMPONENTS

REF NO	PART NO	DESCRIPTION	Qty			
			1560N	1510N	1560N-7	1510N-7
1	23-0501	FEED BASE ASM	1		1	
2	23-0502	FEED BASE	1		1	
3	23-0503	FEED BAR FORK	1		1	
4	23-0504	SCREW 15/64-28 L=14	1	1	1	1
5	23-0505	WASHER	1	1	1	1
6	23-0506	SCREW M5 L=5	1	1	1	1
7	23-0507	FEED BAR SHAFT	1	1	1	1
8	23-0508	SNAP RING 5	1	1	1	1
9	23-0509	OIL WICK	1	1	1	1
10	23-0510	FEED ROCKER	1	1	1	1
11	23-0511	SCREW 11/64-40 L=14	2	2	2	2
12	23-0512	FEED ROCK SHAFT	1	1	1	1
13	23-0513A	FEED SHAFT METAL	1	1	1	1
14	23-0305	SCREW 15/64-28 L=10.5	1	1	1	1
15	23-0515	FEED ROCKER SHAFT CRANK	1	1	1	1
16	23-0516	SCREW 3/16-28 L=15.5	1	1	1	1
17	23-0517	MAIN SHAFT THRUST COLLAR ASM	2	2	2	2
18	23-0407	MAIN SHAFT THRUST COLLAR	2	2	2	2
19	23-0408	SCREW 1/4-40 L=6	4	4	4	4
20	23-0520	NEEDLE BAR FRAME ROD	1	1	1	1
21	23-0521	HINGE SCREW D=9 H=7	1	1	1	1
22	23-0522	NUT 9/32-28	1	1	1	1
23	23-0523	FEED ADJUSTING BASE	1	1	1	1
24	23-0524	FEED ADJUSTING BASE COVER	2	2	2	2
25	23-0315	SCREW 11/64-40 L=8.5	4	4	4	4
26	23-0526	SQUARE BLOCK	2	2	2	2
27	23-0527	FEED ADJUSTING BASE SUPPORT	2	2	2	2
28	23-0206	SCREW 15/64-28 L=8	2	2	2	2
29	23-0529	FELT SUPPORT	1	1	1	1
30	23-0530	SCREW 9/64-40 L=6	2	2	2	2
31	23-0531	ECCENTRIC PIN	1	1	1	1
32	23-0532	SCREW 9/64-40 L=8.5	2	2	2	2
33	23-0533	FEED ADJUSTING ROD	1	1	1	1
34	23-0534	HINGE SCREW D=8 H=4	1	1	1	1
35	23-0535	SPRING	1	1	1	1
36	23-0536	SPRING HOOK	1	1	1	1
37	23-0537	SCREW 11/64-40 L=16	2	2	2	2
38	23-0538	FEED ADJUSTING A	1	1	1	1
39	23-0539	FEED DRIVING SLIDE BLOCK	1		1	
40	23-0540	SCREW M6 L=18	1	1	1	1
41	23-0541	FEED DIAL A	1	1	1	1
42	23-0542*	FEED DOG	1		1	
43	23-0543	SCREW 3/16-28 L=18	1	1	1	1
44	23-0544	FEED REGULATOR SCREW	1	1	1	1
45	23-0545	RUBBER RING	1	1	1	1
46	23-0546	PIN	1	1	1	1
47	23-0547	FEED REGULATOR PIN SPRING	1	1	1	1
48	23-0548	FEED LINK ASM	1	1	1	1
49	23-0549	FEED LINK	1	1	1	1
50	23-0550	CONNECTING FORKED LINK PIN	1	1	1	1

## 5. FEED MECHANISM COMPONENTS

REF NO	PART NO	DESCRIPTION	Qty			
			1560N	1510N	1560N-7	1510N-7
51	23-0551	OIL WICK	1	1	1	1
52	23-0552	SCREW M5 L=6	1	1	1	1
53	23-0553	FEED ROD A1	1	1	1	1
54	23-0554	FEED LINK PIN	1	1	1	1
55	23-0555	HINGE SCREW D=10 H=8	1	1	1	1
56	23-0556	BACKWARD FEED LEVER SHAFT	1	1	1	1
57	23-0557	SCREW 1/8-40 L=7	2		2	
58	23-0558	THRUST COLLAR ASM	1	1	1	1
59	23-0559	THRUST COLLAR	1	1	1	1
60	23-0408	SCREW 1/4-40 L=6	2	2	2	2
61	23-0561	E-RING 9	1	1	1	1
62	23-0562	REVERSE FEED CONTROL LEVER	1	1	1	1
63	23-0563	SCREW 3/16-28 L=9	2	2		
64	23-0564	FELT	1	1	1	1
65	23-0565	NUT 1/8-44	1		1	
66	23-0566	SCREW 1/8-44 L=18	1		1	
67	23-0513B	FEED SHAFT METAL	1	1	1	1
68	23-0567	SCREW 11/64-40 L=4.5	1	1	1	1
69	23-0569	FEED ROCK SHAFT HINGE SCREW	1	1	1	1
70	23-0570	WASHER	1	1	1	1
71	23-0571	NUT 15/64-28	1	1	1	1
72	25-0502	FEED BASE		1		1
73	25-0503	FEED BAR FORK		1		1
74	25-0587	FEED DOG		1		1
75	25-0588	SCREW 1/8-44 L=9		2		2

# 6. HOOK SHAFT & LOWER SHAFT COMPONENTS

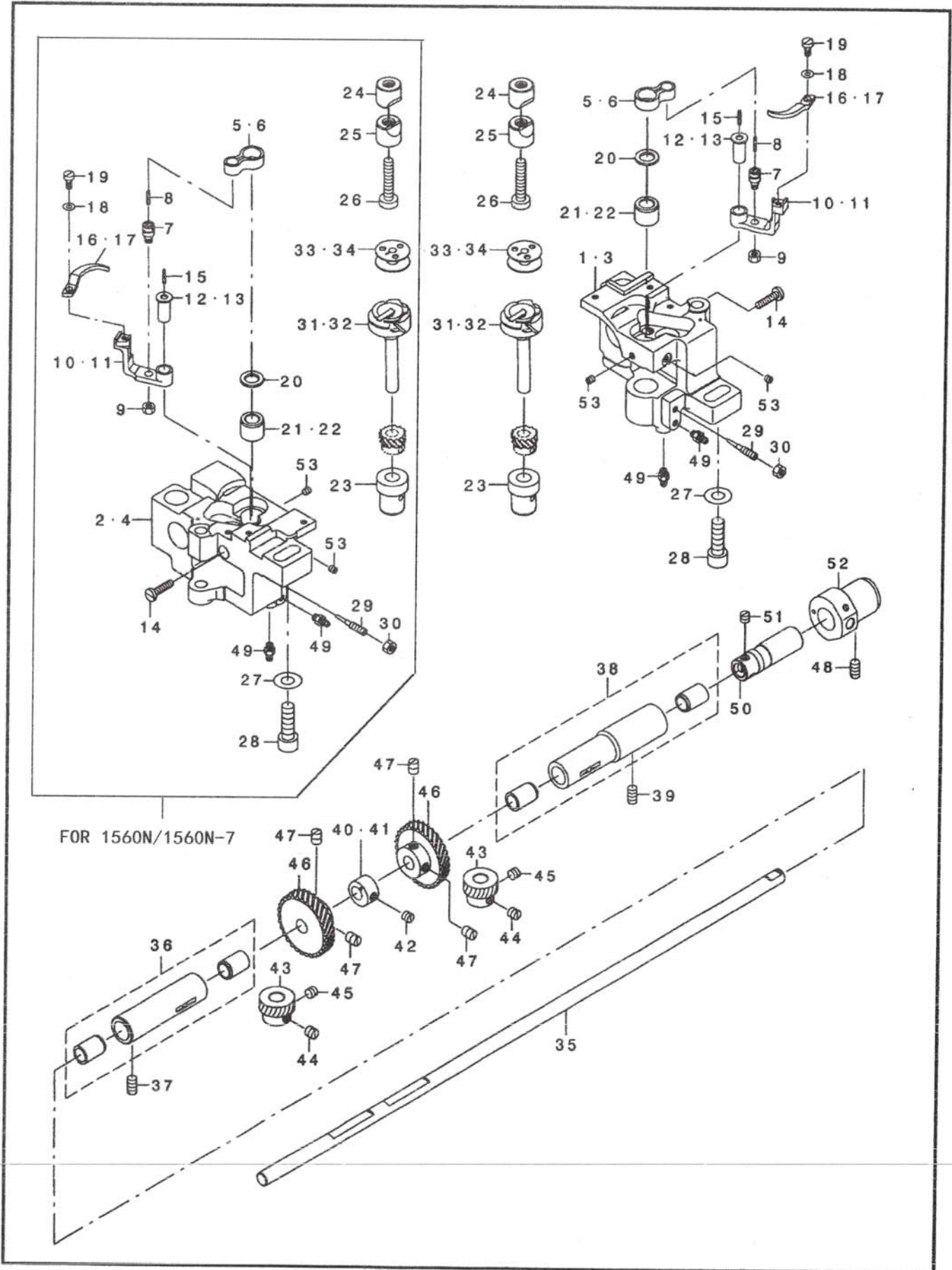



## 6. HOOK SHAFT & LOWER SHAFT COMPONENTS

REF NO	PART NO	DESCRIPTION	Qty			
			1560N	1510N	1560N-7	1510N-7
1	39-0601	HOOK SHAFT BASE (RIGHT)			1	1
2	39-0602	HOOK SHAFT BASE (LEFT)			1	
3	23-0603	HOOK SHAFT BASE (RIGHT)	1	1		
4	23-0604	HOOK SHAFT BASE (LEFT)	1			
5	39-0605	INNER HOOK GUIDE LINK			2	1
6	23-0606	INNER HOOK GUIDE LINK	2	1		
7	23-0607	CRANK SCREW STUD	2	1	2	1
8	23-0608	OIL WICK	2	1	2	1
9	23-0609	NUT 11/64-40	2	1	2	1
10	39-0610	GUIDE ARM (FOR THREAD CUTTING)			2	1
11	23-0611	BOBBIN CASE OPENING LEVER CRAN	2	1		
12	39-0612	INNER HOOK GUIDE ARM SHAFT			2	1
13	23-0613	OPENING LEVER CRANK PIN	2	1		
14	23-0614	SCREW 11/64-40 L=18	2	1	2	1
15	23-0615	OIL WICK	2	1	2	1
16	39-0616	INNER HOOK GUIDE			2	1
17	23-0617	BOBBIN CASE OPENING LEVER	2	1		
18	23-0618	WASHER	2	1	2	1
19	23-0619	SCREW 9/64-40 L=7.5	2	1	2	1
20	23-0620	THRUST WASHER	2	1	2	1
21	39-0622	HOOK SHAFT UPPER MWTAL			2	1
22	23-0623	HOOK SHAFT UPPER MWTAL	2	1		
23	23-0624	HOOK SHAFT LOWER METAL	2	1	2	1
24	23-0625	SADDLE INSTALLING BLOCK UPPER	2	1	2	1
25	23-0626	SADDLE INSTALLING BLOCK LOWER	2	1	2	1
26	23-0627	SCREW 15/64-28 L=30	2	1	2	1
27	23-0628	WASHER	2	1	2	1
28	23-0629	SCREW M8 L=25	2	1	2	1
29	23-0630	OIL ADJUSTING SCREW	2	1	2	1
30	23-0609	NUT 11/64-40	2	1	2	1
31	39-0632	THREAD TRIMMER HOOK ASM			2	1
32	23-0633	VERTICK-AXIS SEWING HOOK ASM	2	1		
33	39-0634	ALUMINUM BOBBIN WITH KNURL			2	1
34	23-0635	BOBBIN	2	1		
35	23-0636	LOWER SHAFT	1	1	1	1
36	23-0637	BUSHING ASM FRONT	1		1	
37	23-0305	SCREW 15/64-28 L=10.5	1		1	
38	23-0640	BUSHING ASM INTERMEDIATE	1	1	1	1
39	23-0305	SCREW 15/64-28 L=10.5	1	1	1	1
40	39-0641	FEED DRIVING ECCENTRIC			1	1
41	23-0642	FEED DRIVING CAM	1	1		
42	23-0644	SCREW 1/4-40 L=4.5	1	1	1	1
43	23-0645	HOOK DRIVING SHAFT GEAR SMALL	2	1	2	1
44	23-0644	SCREW 1/4-40 L=4.5	2	1	2	1
45	23-0646	SCREW 1/4-40 L=6.1	2	1	2	1
46	23-0648	HOOK DRIVING SHAFT GEAR LARGE	2	1	2	1
47	23-0216	SCREW 1/4-40 L=8	4	2	4	2
48	23-0305	SCREW 15/64-28 L=10.5	1	1	1	1
49	23-1539	CONNECTING SCREW	4	2	4	2
50	23-0652	OIL PUMP SHAFT	1	1	1	1
51	23-0644	SCREW 1/4-40 L=4.5	3	3	3	3
52	23-0654	PLUNGER BUSHING B	1	1	1	1
53	23-0655	SCREW 11/64-40 L=4	4	2	4	2

# 7. THREAD CUTTING COMPONENTS (FOR 1560N-7/1510N-7)

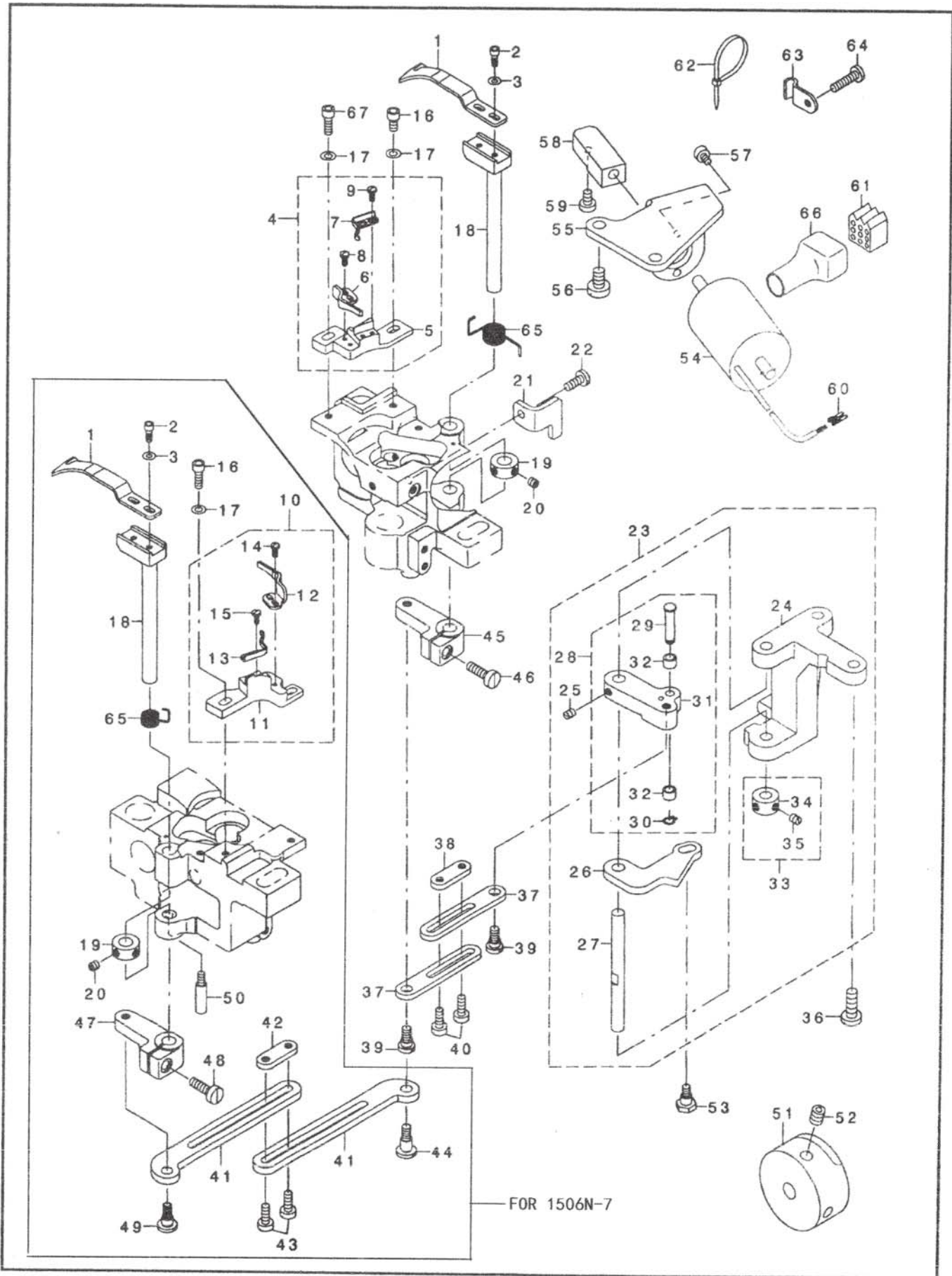

## 7. THREAD CUTTING COMPONENTS (FOR 1560N-7/1510N-7)

REF NO	PART NO	DESCRIPTION	Qty			
			1560N	1510N	1560N-7	1510N-7
1	39-0701	MOVING KNIFE			2	1
2	39-0702	SCREW M3 L=8			4	2
3	39-0703	WASHER			4	2
4	39-0704	FIXED KNIFE BASE (RIGHT) ASM			1	1
5	39-0705	FIXED KNIFE BASE (RIGHT)			1	1
6	39-0706	FIXED KNIFE			1	1
7	39-0713	CLAMP SPRING			1	1
8	39-0708	SCREW 3/32-56 L=5.5			2	2
9	39-0708	SCREW 3/32-56 L=5.5			2	2
10	39-0710	FIXED KNIFE BASE (LEFT) ASM			1	
11	39-0711	FIXED KNIFE BASE (LEFT)			1	
12	39-0706	FIXED KNIFE			1	
13	39-0713	CLAMP SPRING			1	
14	39-0708	SCREW 3/32-56 L=5.5			2	
15	39-0708	SCREW 3/32-56 L=5.5			2	
16	39-0716	SCREW M4 L=12			3	1
17	39-0717	WASHER			4	2
18	39-0718	MOVING KNIFE SHAFT			2	1
19	39-0719	THRUST COLLAR			2	1
20	20-0337	SCREW 11/64-40 L=4			4	2
21	39-0721	THREAD CUTTING STOPPER (RIGHT)			1	
22	20-0408	SCREW 11/64-40 L=10.5			1	
23	39-0723	VERTICAL FITTING BASIS ASM			1	1
24	39-0724	VERTICAL FITTING BASIS			1	1
25	01-1104	SCREW 11/64-40 L=5			2	2
26	39-0726	THREAD CUTTING DRIVING PLATE			1	1
27	39-0727	SHAFT			1	1
28	39-0728	THREAD CUTTING ROLLER ARM ASM			1	1
29	39-0729	CAM ROLLER SHAFT			1	1
30	39-0730	SNAP RING			1	1
31	39-0731	THREAD CUTTING ROLLER ARM			1	1
32	39-0732	CAM ROLLER			2	2
33	39-0733	THRUST COLLAR ASM			1	1
34	39-0734	THRUST COLLAR			1	1
35	01-1104	SCREW 11/64-40 L=5			2	2
36	39-0736	SCREW 15/64-28 L=16			2	2
37	39-0737	CONNECTING PLATE			2	2
38	39-0738	STOPPING PLATE			1	1
39	39-0739	HINGE SCREW			1	2
40	23-0170	SCREW 11/64-40 L=11			2	2
41	39-0741	CONNECTING PLATE			2	
42	39-0742	STOPPING PLATE			1	
43	23-0170	SCREW 11/64-40 L=11			2	
44	39-0744	HINGE SCREW D=6.35 H=7.5			1	
45	39-0745	ROCKING ARM (RIGHT)			1	1
46	20-0546	SCREW 3/16-28 L=15.5			1	1
47	39-0747	ROCKING ARM (LEFT)			1	
48	20-0546	SCREW 3/16-28 L=15.5			1	
49	39-0749	HINGE SCREW D=6.35 H=4.5			1	
50	39-0750	HAND LIFTER SHAFT			1	

**7. THREAD CUTTING COMPONENTS (FOR 1560N-7/1510N-7)**

REF NO	PART NO	DESCRIPTION	Qty			
			1560N	1510N	1560N-7	1510N-7
51	39-0751	THREAD TRIMMER CAM			1	1
52	23-0403	SCREW 1/4-40 L=6			2	2
53	39-0753	HINGE SCREW D=6.35 H=4.8			1	1
54	39-0754	THREAD CUTTING SOLENOID			1	1
55	39-0755	SOLENOID FITTING PLATE			1	1
56	39-0756	SCREW 15/64-28 L=10			2	2
57	39-0757	SCREW M4 L=8			2	2
58	39-0758	SOLENOID CONNECTING PLATE			1	1
59	23-0453	SCREW 11/64-40 L=6.5			2	2
60	39-0760	PIN CONTACT			2	2
61	39-0761	HOUSING 14P			1	1
62	23-0174	CABLE BAND			1	1
63	39-0763	PIPE HOLDER			1	1
64	39-0764	SCREW 11/64-40 L=18			1	1
65	39-0765	MAINTENANCE SPRING			2	1
66	39-0766	12-POLE RECEPTACLE COVER			1	1
67	39-0767	SCREW M4 L=8			1	1

## 8. AUTOMATIC BACK COMPONENTS (FOR 1560N-7/1510N-7)

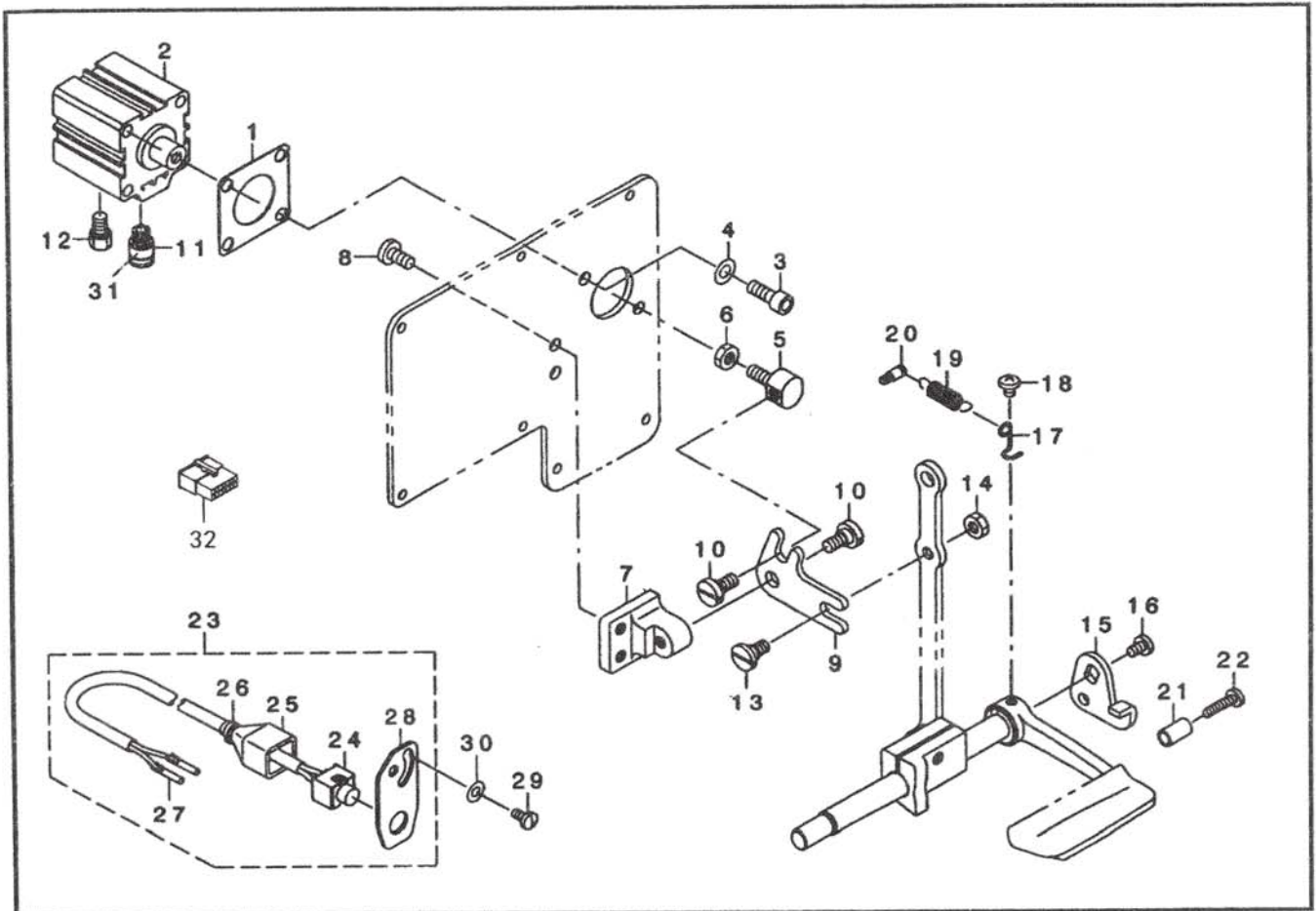

REF NO	PART NO	DESCRIPTION	Qty			
			1560N	1510N	1560N-7	1510N-7
1	39-0801	CYLINDER PACKING			1	1
2	39-0802	JIGCYLINDER			1	1
3	39-0803	SCREW M6 L=16			2	2
4	39-0804	WASHER			2	2
5	39-0805	CYLINDER CONNECTING SCREW			1	1
6	39-0806	NUT M6			2	2
7	39-0807	FITTING BASE			1	1
8	39-0808	SCREW 15/64-28 L=12			2	2
9	39-0809	BACKWARD FEED LINK			1	1
10	39-0810	HINGE SCREW D=8 H=3.5			2	2
11	39-0811	HALF UNION			1	1
12	39-0812	MUFFLER			1	1
13	39-0813	HINGE SCREW D=8 H=4			1	1
14	39-0814	NUT 15/64-28			1	1
15	39-0815	REVERSE FEED LINK (1)			1	1
16	39-0816	SCREW 3/16-28 L=7			1	1
17	39-0817	SPRING SUSPENSION			1	1
18	39-0818	SCREW 3/16-28 L=6			1	1
19	39-0819	SPRING			1	1
20	39-0820	SPRING SUSPENSION			1	1
21	39-0821	REVERSE FEED LEVER STOPPER			1	1
22	39-0822	SCREW 11/64-40 L=18			1	1
23	39-0823	TOUCH BUCK SWITCH WHOLE ASM			1	1
24	39-0824	TOUCH BUCK SWITCH ASM			1	1
25	39-0825	4-POLE NYLON PLUG COVER			1	1
26	39-0826	CLIP CV-70S			1	1
27	39-0827	PIN TERMINAL MALE			2	2
28	39-0828	SWITCH FITTING PLATE			1	1
29	39-0829	SCREW 11/64-40 L=7.8			2	2
30	39-0830	WASHER			2	2
31	39-0831	WIRE MARK (1)			1	1
32	39-0832	HOUSING 14P			1	1

# 9. THREAD TENSION COMPONENTS (FOR 1560N/1560N-7)

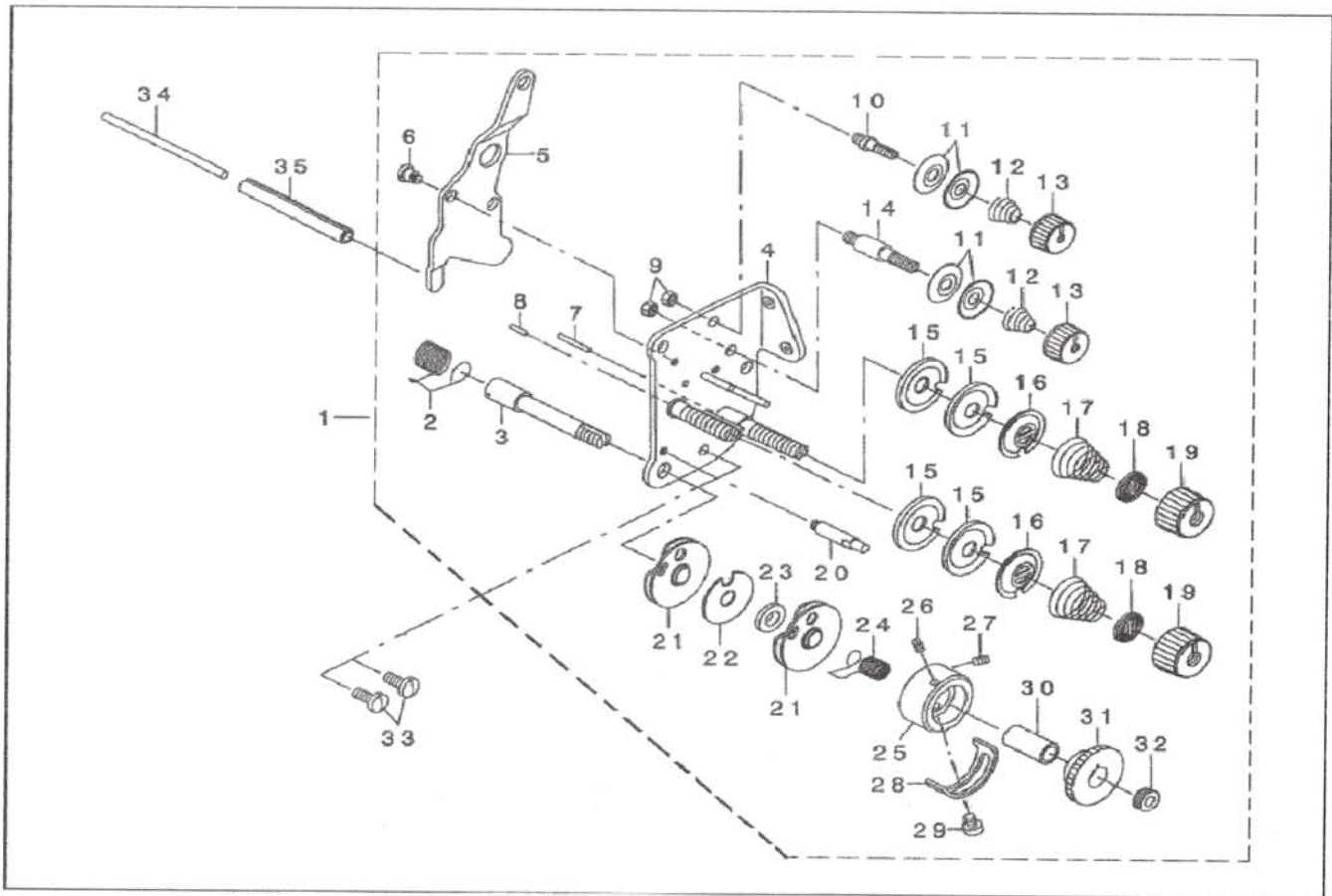

REF NO	PART NO	DESCRIPTION	Qty			
			1560N	1510N	1560N-7	1510N-7
1	23-0901	THREAD TENSION ASM	1		1	
2	23-0902	THREAD TAKE-UP SPRING A	1		1	
3	23-0903	THREAD TAKE-UP SPRING STUD	1		1	
4	23-0904	THREAD TENSION BASE COMPL	1		1	
5	23-0905	THREAD RELEASE PLATE	1		1	
6	23-0906	HINGE SCREW D=4.7 H=2.8	2		2	
7	23-0907	PIN B	1		1	
8	23-0908	TENSION RELEASE PIN SHORT	1		1	
9	23-0909	NUT 11/64-40	2		2	
10	23-0910	THREAD TENSION POST A	1		1	
11	23-0911	BOBBIN WINDER TENSION DISC	4		4	
12	23-0912	TENSION SPRING NO. 1	2		2	
13	23-0913	THERAD TENSION NUT	2		2	
14	23-0914	THREAD TENSION POST B	1		1	
15	23-0915	TENSION DISC	4		4	
16	23-0916	TENSION DISC HOLDER	2		2	
17	23-0917	TENSION SPRING	2		2	
18	23-0918	ROTATING STOPPER	2		2	
19	23-0919	TENSION NUT	2		2	
20	23-0920	TAKE-UP SPRING GUIDE STUD	1		1	
21	23-0921	TAKE-UP SPRING GUIDE ASM	2		2	
22	23-0922	TAKE-UP SPRING GUIDE PLATE	1		1	
23	23-0923	COLLAR	1		1	
24	23-0924	THREAD TAKE-UP SPRING B	1		1	
25	23-0925	THRWD TENSION POST	1		1	
26	23-0926	SCREW 1/8-44 L=3.5	1		1	
27	23-0927	SCREW 1/8-44 L=3.5	1		1	
28	23-0928	ADJUSTING PLATE B	1		1	
29	23-0929	SCREW 7/64 40 L=4.5	1		1	
30	23-0930	PRESSER COLLAR	1		1	
31	23-0931	TAKE-UP SPRING GUIDE	1		1	
32	23-0932	THREAD TENSION NUT	1		1	
33	23-0315	SCREW 11/64-40 L=8.5	2		2	
34	23-0935	TENSION RELEASE BAR	1		1	
35	23-0937	SPRING PIN	1		1	

## 9. THREAD TENSION COMPONENTS (FOR 1510N/1510N-7)

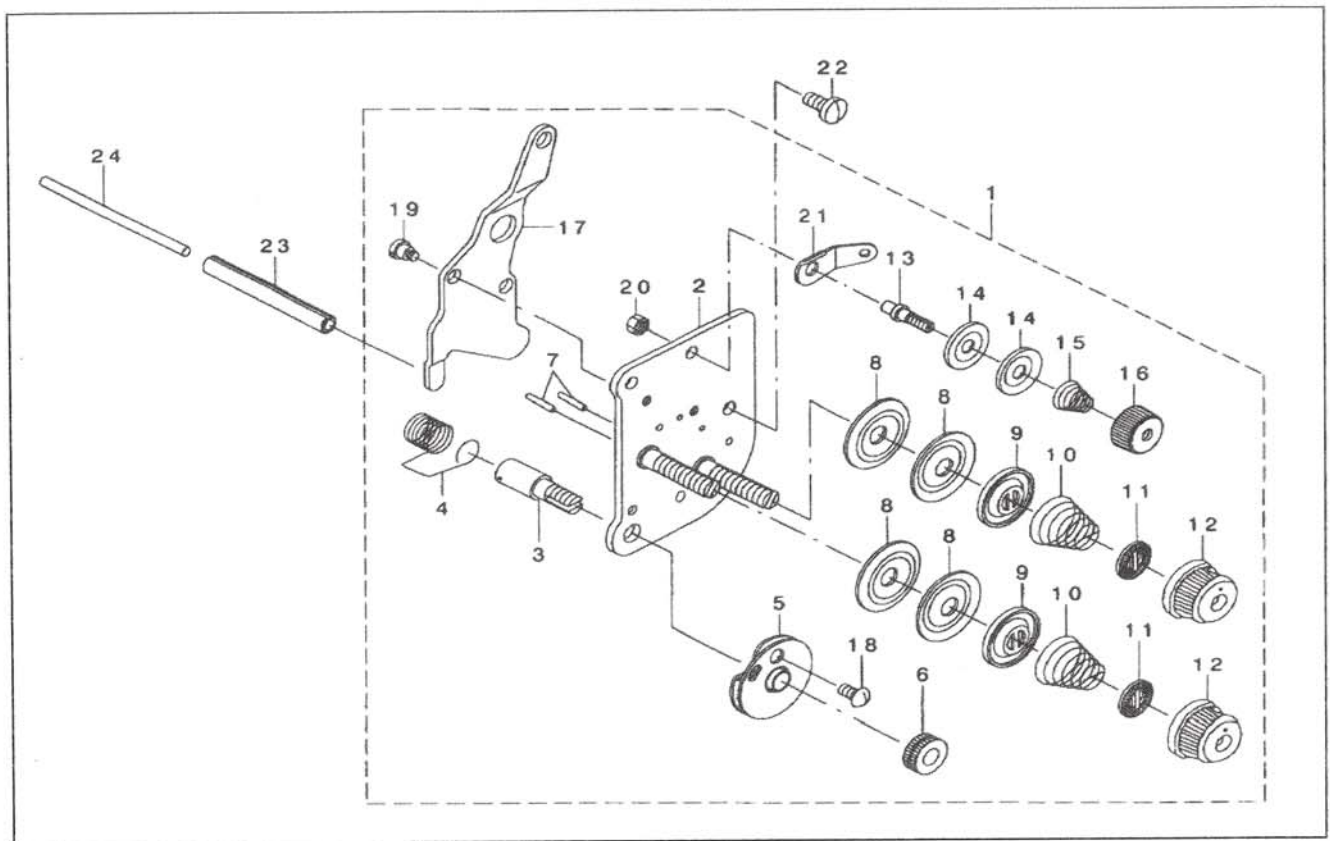

REF NO	PART NO	DESCRIPTION	Qty			
			1560N	1510N	1560N-7	1510N-7
1	25-0701	THREAD TENSION ASM		1		1
2	25-0702	THREAD TENSION BASE COMPL		1		1
3	25-0703	THREAD TAKE-UP SPRING STUD		1		1
4	25-0704	THREAD TAKE-UP SPRING A		1		1
5	25-0705	TAKE-UP SPRING GUIDE ASM		1		1
6	23-0932	THREAD TENSION NUT		1		1
7	25-0707	PIN B		2		2
8	25-0708	TENSION DISC		4		4
9	25-0709	TENSION DISC HOLDER		2		2
10	25-0710	TENSION SPRING		2		2
11	23-0918	ROTATING STOPPER		2		2
12	25-0712	TENSION NUT		2		2
13	23-0910	THREAD TENSION POST A		1		1
14	25-0714	FIRST THREAD TENSION PLATE		2		2
15	25-0715	THREAD TENSION SPRING		1		1
16	23-0913	THERAD TENSION NUT		1		1
17	23-0905	THREAD RELEASE PLATE		1		1
18	25-0718	SCREW 9/64-40 L=7		1		1
19	23-0906	HINGE SCREW D=4.7 H=2.8		2		2
20	23-0909	NUT 11/64-40		1		1
21	25-0721	THREAD GUIDE		1		1
22	23-0315	SCREW 11/64-40 L=8.5		2		2
23	23-0937	SPRING PIN		1		1
24	23-0935	TENSION RELEASE BAR		1		1

## 10. THREAD RELEASE COMPONENTS (FOR 1560N-7/1510N-7)

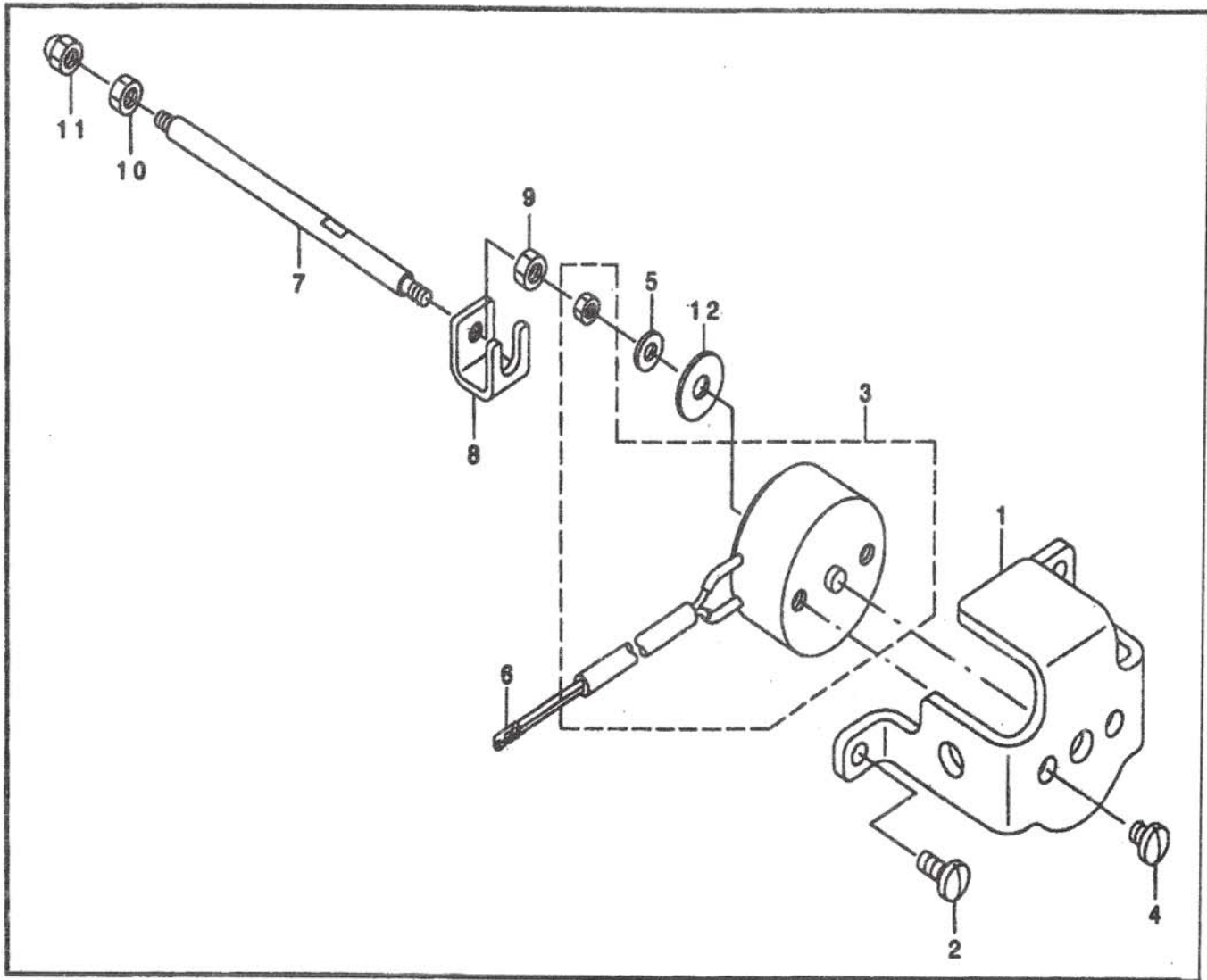

REF NO	PART NO	DESCRIPTION	Qty			
			1560N	1510N	1560N-7	1510N-7
1	39-1001	SOLENOID INSTALLING PLATE			1	1
2	03-0303	SCREW 11/64-40 L=8.5			2	2
3	39-1003	TENSION RELEASE SOLENOID			1	1
4	39-1004	SCREW 11/64-40 L=4.8			2	2
5	39-1005	WASHER			1	1
6	39-1006	PIN TERMINAL MALE			2	2
7	39-1007	TENSION RELEASE BAR			1	1
8	39-1008	COUPLING			1	1
9	30-1009	NUT M4			1	1
10	39-1010	NUT M4			1	1
11	39-1011	NUT M4			1	1
12	39-1012	WASHER			1	1



# 15. LUBRICATION COMPONENTS

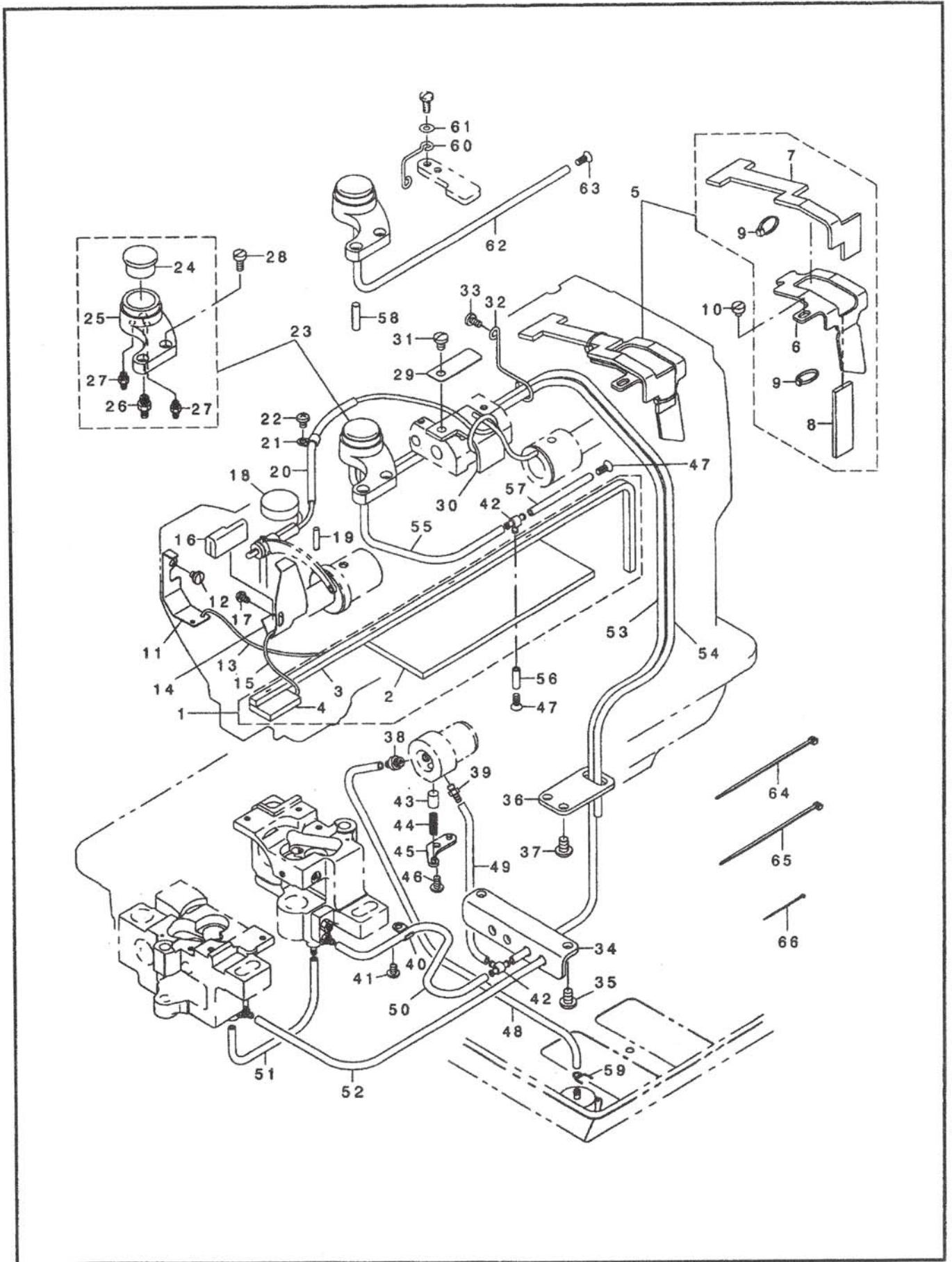

## 15. LUBRICATION COMPONENTS

REF NO	PART NO	DESCRIPTION	Qty			
			1560N	1510N	1560N-7	1510N-7
1	23-1501	ARM ONCE THROUGH OIL FELT ASM	1	1	1	1
2	23-1502	ARM ONCE THROUGH FELT A	1	1	1	1
3	23-1503	FELT B	1	1	1	1
4	23-1504	ARM ONCE THROUGH FELT	1	1	1	1
5	23-1505	FELT SUPPORT ASM	1	1	1	1
6	23-1506	FELT	1	1	1	1
7	23-1507	FEED CHANGE FELT	1	1	1	1
8	23-1508	FELT	1	1	1	1
9	23-0414	CLIP CV-70S	2	2	2	2
10	23-1510	SCREW 11/64-40 L=4.3	1	1	1	1
11	23-1511	UPPER FEED OIL PLATE	1	1	1	1
12	23-1512	SCREW 11/64-40 L=5	1	1	1	1
13	23-1513	OIL WICK	1	1	1	1
14	23-1514	TAKE-UP OIL PLATE	1	1	1	1
15	23-1515	OIL WICK	1	1	1	1
16	23-1516	TAKE-UP LUBRICATION FELT	1	1	1	1
17	23-1517	SCREW 9/64-40 L=6	1	1	1	1
18	23-1518	FELT	1	1	1	1
19	23-1519	FELT	1	1	1	1
20	23-1520	OIL TUBE	1	1	1	1
21	23-1521	OIL RETURN TUBE HOLDER	1	1	1	1
22	23-1541	SCREW 11/64-40 L=6	1	1	1	1
23	23-1523	ARM OIL TANK ASM	1	1	1	1
24	23-1524	OIL SIGHT WINDOW	1	1	1	1
25	23-1525	ARM OIL TANK	1	1	1	1
26	23-1538	CONNECTING SCREW	1	1	1	1
27	23-1539	CONNECTING SCREW	2	2	2	2
28	23-1528	SCREW 11/64-40 L=9.5	2	2	2	2
29	23-1529	LUBRICATION FELT PRESSER	1	1	1	1
30	23-1530	MUTUAL VERTICAL CHANGE FELT	1	1	1	1
31	23-1531	SCREW 3/16-28 L=7	1	1	1	1
32	23-1532	PIPE SUPPORT	1	1	1	1
33	23-0317	SCREW 11/64-40 L=7.5	1	1	1	1
34	23-1534	LUBRICATION BRACKET	1	1	1	1
35	23-1535	SCREW 15/64-28 L=9	2	2	2	2
36	23-1536	OIL PIPE STAY	1	1	1	1
37	23-1535	SCREW 15/64-28 L=9	2	2	2	2
38	23-1538	CONNECTING SCREW	1	1	1	1
39	23-1539	CONNECTING SCREW	1	1	1	1
40	23-1521	OIL RETURN TUBE HOLDER	1	1	1	1
41	23-1541	SCREW 11/64-40 L=6	1	1	1	1
42	23-1542	OIL CONNEC ARM	2	2	2	2
43	23-1543	PLUNGER	1	1	1	1
44	23-1544	PLUNGER SPRING	1	1	1	1
45	23-1545	PLUNGER THRUST PLATE	1	1	1	1
46	23-0105	SCREW 11/64-40 L=8	1	1	1	1
47	23-1564	SCREW M4 L=10	2	2	2	2
48	23-1548	TUBE	1	1	1	1
49	23-1549	TUBE	1	1	1	1
50	23-1550	TUBE	1	1	1	1

# 11. KNEE LIFTING COMPONENTS

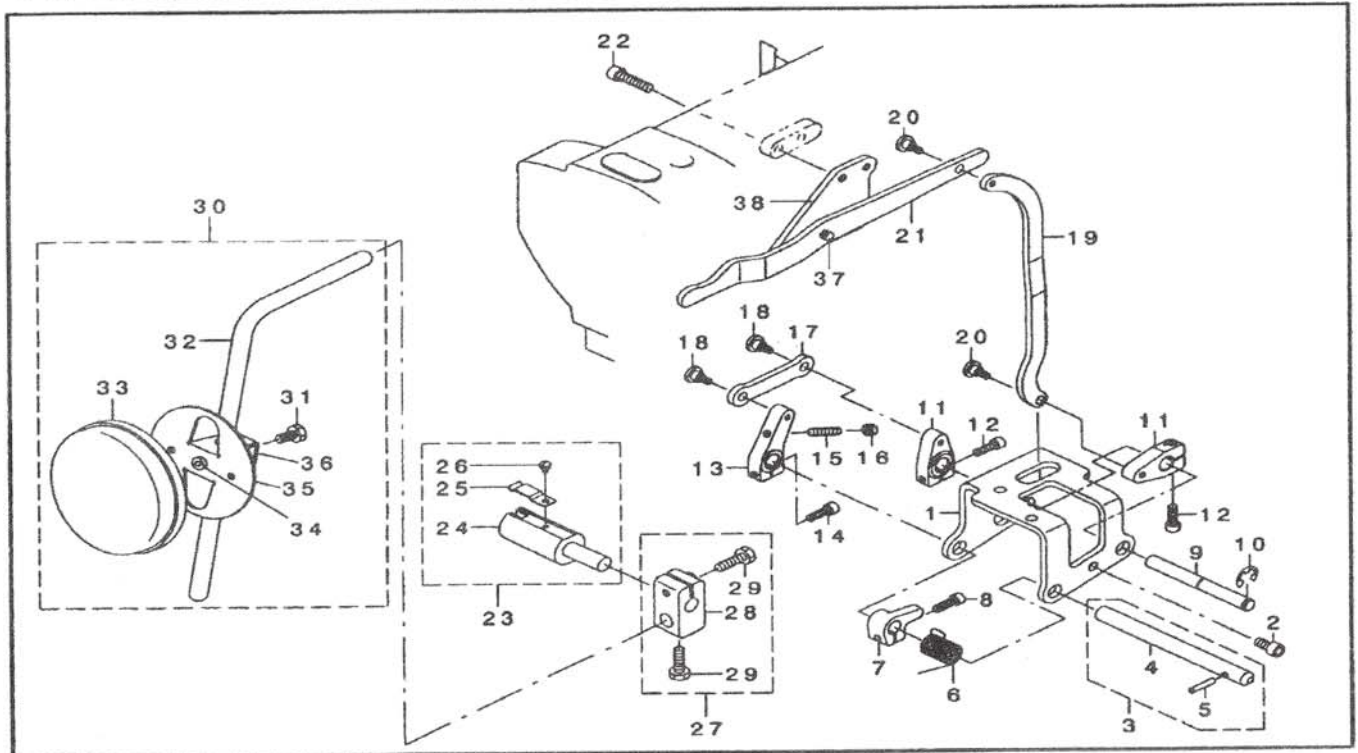

REF NO	PART NO	DESCRIPTION	Qty			
			1560N	1510N	1560N-7	1510N-7
1	23-1101	KNEE LIFTER SHAFT BASIS	1	1		
2	23-1102	SCREW M6 L=12	3	3		
3	23-1103	KNEE LIFTER SHAFT A ASM	1	1		
4	23-1104	KNEE LIFTER SHAFT A	1	1		
5	23-1105	KNEE LIFTER SHAFT PIN	1	1		
6	23-1106	KNEE LIFTER SHAFT A SPRING	1	1		
7	23-1107	KNEE LIFTER SPRING RACK	1	1		
8	23-1108	SCREW M5 L=16	1	1		
9	23-1109	KNEE LIFTER SHAFT B	1	1		
10	23-1110	E-SHAPED SNAP RING (8MM)	1	1		
11	23-1111	KNEE LIFTER LEVER B	2	2		
12	23-1108	SCREW M5 L=16	2	2		
13	23-1113	KNEE LIFTER LEVER A	1	1		
14	23-1108	SCREW M5 L=16	1	1		
15	23-1115	SCREW M5 L=25	1	1		
16	23-1116	NUT M5	1	1		
17	23-1117	KNEE LIFTER LINK	1	1		
18	23-1120	HINGE SCREW D=7 H=4.5	2	2		
19	23-1119	KNEE LIFTER CONNECTING PLATE	1	1		
20	23-1120	HINGE SCREW D=7 H=4.5	2	2		
21	23-1121	KNEEL LIFTER LEVER	1	1		
22	23-1122	SCREW M6 L=25	2	2		
23	23-1123	KNEE LIFTER JOINT ASM	1	1		
24	23-1124	KNEE LIFTER JOINT ASM	1	1		
25	23-1125	PRESSER SPRING	1	1		
26	23-1126	SCREW 9/64-40 L=4.6	1	1		
27	23-1127	BRACKET ASM	1	1		
28	23-1128	BRACKET ASM	1	1		
29	20-0711	SCREW M6 L=24	2	2		
30	20-0716	KNEE PRESS PLAE ASM	1	1		
31	20-0722	SCREW M6 L=12	1	1		
32	20-0718	KNEE PRESS LEVER	1	1		
33	20-0717	KNEE PAD PLATE COVER	1	1		
34	20-0719	KNEE PAD PLATE RUBBER	1	1		
35	20-0720	KNEE PAD PLATE	1	1		
36	20-0721	KNEE PAD PLATE SUPPORT	1	1		
37	23-1137	HINGE SCREW D=8 H=4.5	1	1		
38	23-1138	KNEE LIFTER LEVER STAY	1	1		

## 12. LOWER THREAD WINDER MECHANISM COMPONENTS

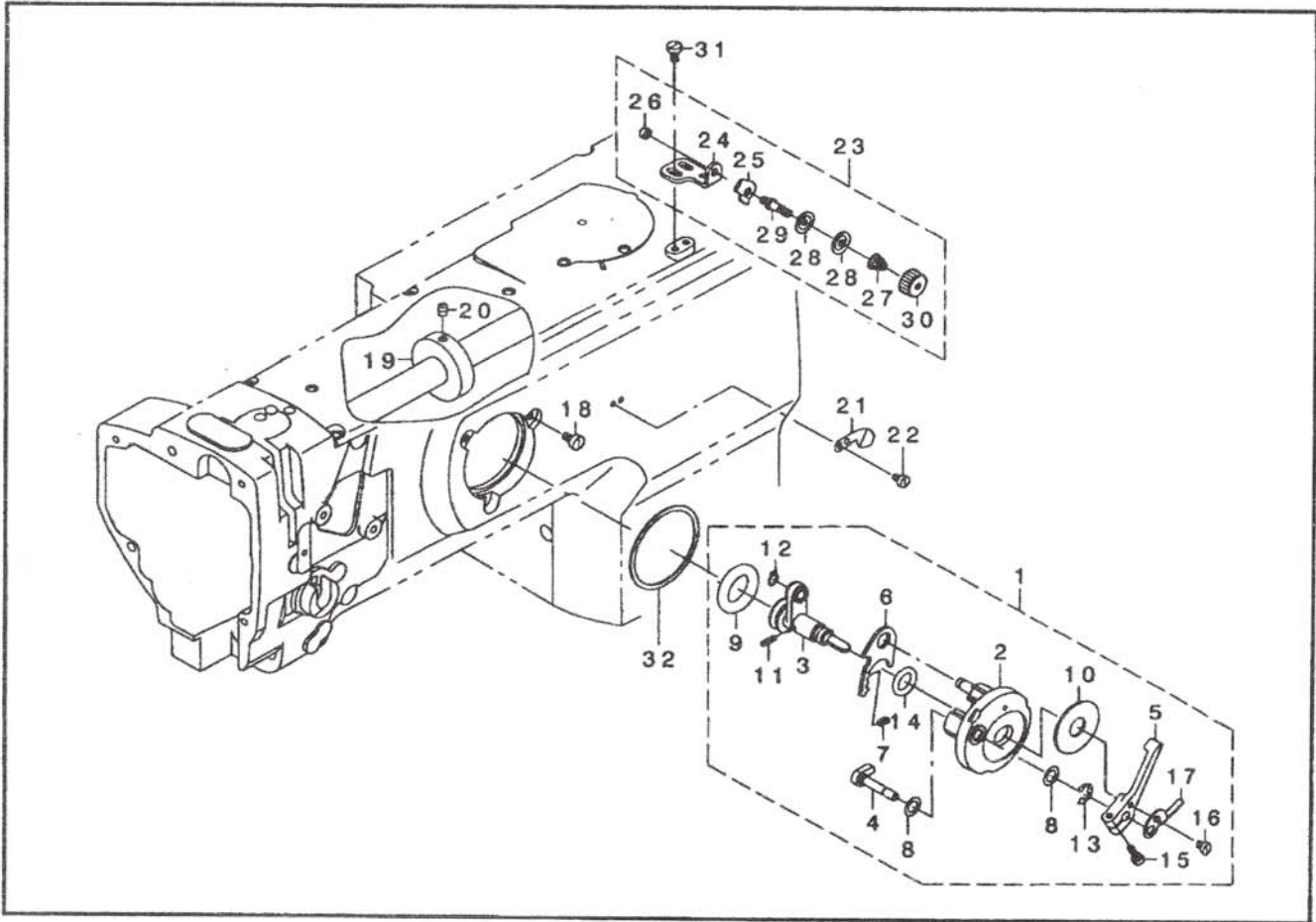

REF NO	PART NO	DESCRIPTION	Qty			
			1560N	1510N	1560N-7	1510N-7
1	23-1201	BOBBIN DEVICE ASM	1	1	1	1
2	23-1202	BOBBIN FITTING BASIS COMPL	1	1	1	1
3	23-1203	BOBBIN SHAFT COMPL	1	1	1	1
4	23-1204	BOBBIN CAM CHAFT COMPL	1	1	1	1
5	23-1205	BOBBIN LEVER	1	1	1	1
6	23-1206	ADJUSTING PLATE	1	1	1	1
7	23-1207	PRESSUR FOOT SPRING	1	1	1	1
8	23-1208	VERTICAL ROLLER WASHER	2	2	2	2
9	23-1209	RUBBER RING	1	1	1	1
10	23-1210	CUSHION	1	1	1	1
11	23-1211	SPRING	1	1	1	1
12	23-1212	RETAINING RING	1	1	1	1
13	23-1213	E-RING	1	1	1	1
14	23-1214	RUBBER RING	1	1	1	1
15	23-1215	SCREW 9/64-40 L=13.5	1	1	1	1
16	23-1216	SCREW 9/64-40 L=5	1	1	1	1
17	23-1217	BOBBIN ADJUSTING PLATE	1	1	1	1
18	23-1218	SCREW 11/64-40 L=8.5	3	3	3	3
19	23-1219	BOBBIN FRICTION WHEEL	1	1	1	1
20	23-1220	SCREW M5 L=6	2	2	2	2
21	23-1221	THREAD CUTTER	1	1	1	1
22	23-1222	SCREW 9/64-40 L=6	2	2	2	2
23	23-1223	LOWER THREAD GUIDE ASM	1	1	1	1
24	23-1224	FITTING BASE	1	1	1	1
25	23-1225	THREAD GUIDE	1	1	1	1
26	23-1226	NUT 11/64-40	1	1	1	1
27	23-1227	TENSION SPRING NO. 1	1	1	1	1
28	23-1228	BOBBIN WINDER TENSION DISC	2	2	2	2
29	23-1229	THREAD TENSION POST	1	1	1	1
30	23-1230	THREAD TENSION NUT	1	1	1	1
31	23-1231	SCREW	2	2	2	2
32	23-1232	PACKING	1	1	1	1

### 13. AUTOMATIC PRESSER LIFTING MECHANISM COMPONENTS (FOR 1560N-7/1510N-7)

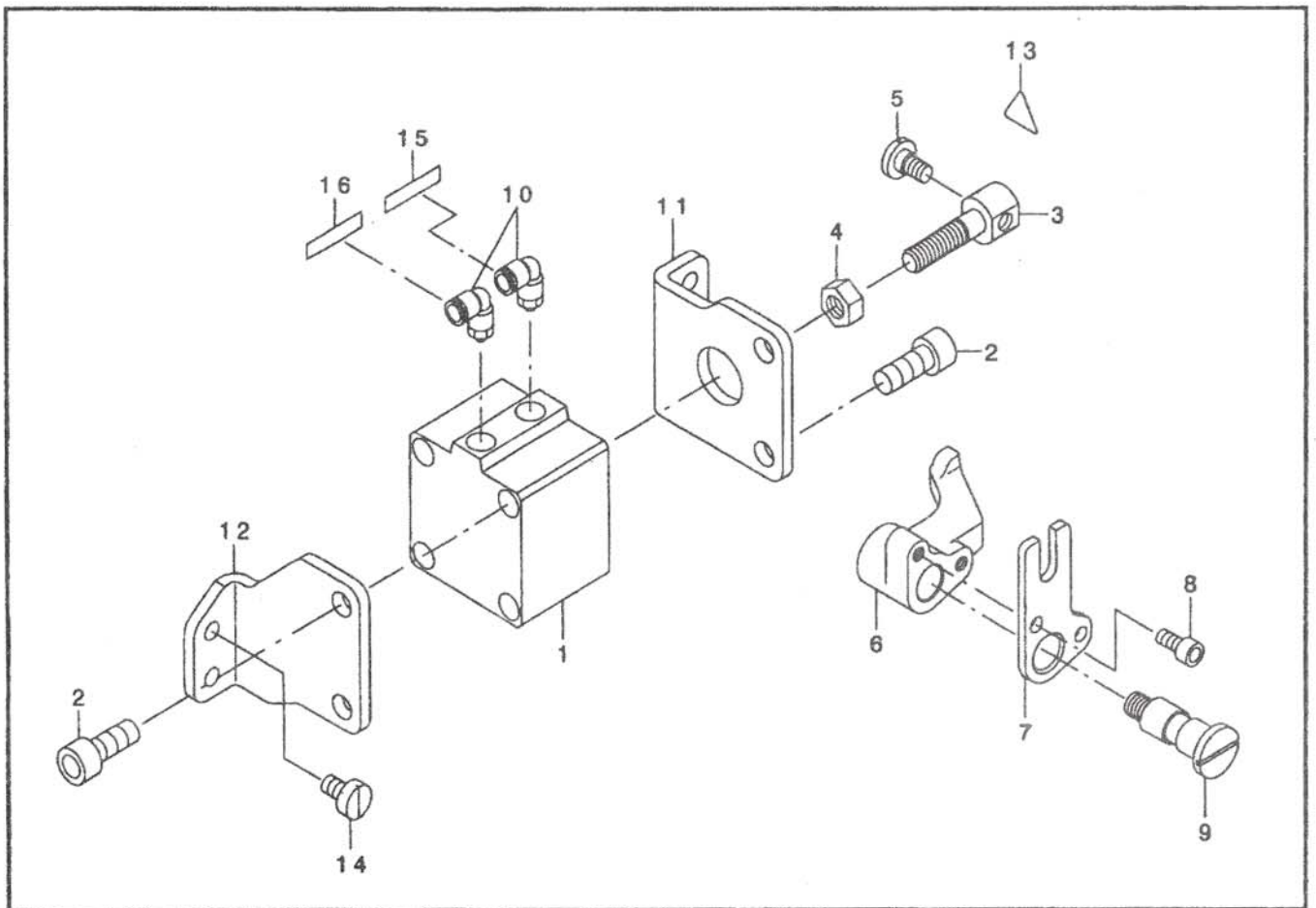

REF NO	PART NO	DESCRIPTION	Qty			
			1560N	1510N	1560N-7	1510N-7
1	39-1301	AIR CYLINDER			1	1
2	39-1302	SCREW M8 L=20			4	4
3	39-1303	CYLINDER CONNECTING SCREW			1	1
4	39-1304	NUT M8			1	1
5	39-1305	HINGE SCREW D=7.24 H=3.3			1	1
6	39-1306	PRESSER LIFTER LEVERA A			1	1
7	39-1307	PRESSER LIFTER LEVERA B			1	1
8	39-1308	SCREW M5 L=10			2	2
9	39-1309	SHAFT			1	1
10	39-1310	ELBOW			2	2
11	39-1311	CYLINDER STAY (FRONT)			1	1
12	39-1312	CYLINDER STAY (RWAR)			1	1
13	39-1313	ATTENTION SEAL			1	1
14	39-1314	SCREW 15/64-28 L=10			4	4
15	39-1315	WIRE MARK (2)			1	1
16	39-1316	WIRE MARK (3)			1	1

## 14. AIR MECHANISM COMPONENTS (FOR 1560N-7/1510N-7)

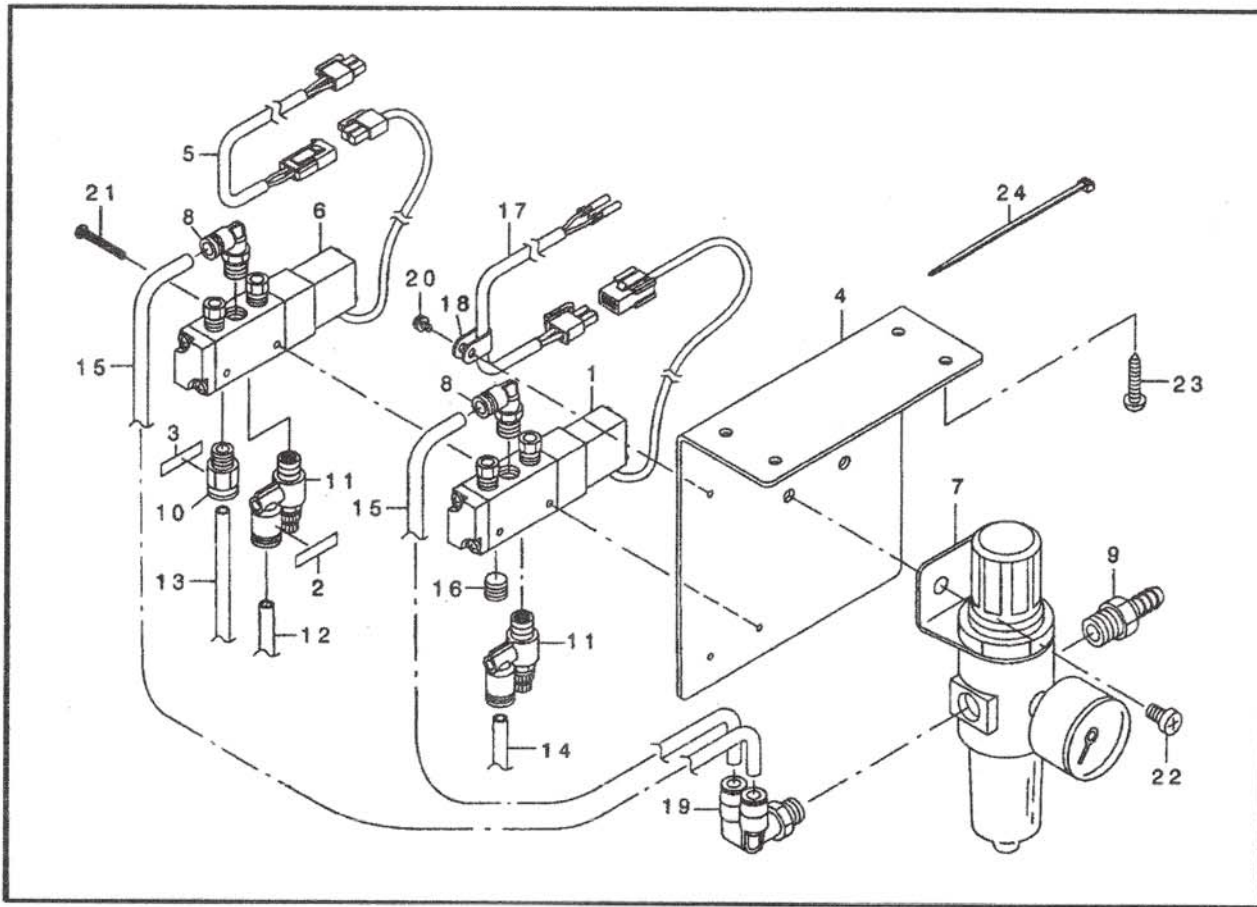

REF NO	PART NO	DESCRIPTION	Qty			
			1560N	1510N	1560N-7	1510N-7
1	39-0839	SOLENOID VALVE ASM			1	1
2	39-1402	WIRE MARK (1)			1	1
3	39-1412	WIRE MARK (2)			1	1
4	39-0803	SOLENOID VALVE MOUNTING PLATE			1	1
5	39-1923	CORD ASM			1	1
6	39-1924	SOLENOID VALVE ASM			1	1
7	39-0833	FILTER REGULATOR			1	1
8	39-1405	ELBOW B			2	2
9	39-1417	NIPPLE			1	1
10	39-1928	JOINT A			1	1
11	39-0837	SPEED CONTROLLER			2	2
12	39-0842	TUBE			1	1
13	39-0842	TUBE			1	1
14	39-0842	TUBE			1	1
15	39-0842	TUBE			2	2
16	39-0840	PLUG 1/8			1	1
17	39-0843	CORD ASM			1	1
18	39-0844	CABLE CLIP			1	1
19	39-1937	JOINT			1	1
20	39-0845	SCREW M3 L=6			1	1
21	39-0846	SCREW M3 L=40			2	2
22	39-0832	SCREW M6 L=10			2	2
23	39-1941	WOOD SCREW D=4.8 L=25			4	4
24	23-1565	CABLE BAND			3	3

### 15. LUBRICATION COMPONENTS

REF NO	PART NO	DESCRIPTION	Qty			
			1560N	1510N	1560N-7	1510N-7
51	23-1551	TUBE	1		1	
52	23-1552	TUBE	1	1	1	1
53	23-1553	TUBE	1	1	1	1
54	23-1554	TUBE	1	1	1	1
55	23-1555	TUBE	1	1	1	1
56	23-1556	TUBE	1	1	1	1
57	23-1557	TUBE	1	1	1	1
58	23-1558	SPRING PIN	1	1	1	1
59	23-1559	OIL TUBE HOLDER	1	1	1	1
60	23-1561	OIL WICK HOLDER	1	1	1	1
61	23-1562	WASHER	1	1	1	1
62	23-1563	TUBE	1	1	1	1
63	23-1564	SCREW M4 L=10	1	1	1	1
64	23-1565	CABLE BAND	1	1	1	1
65	23-1566	CLIP BAND	1	1	1	1
66	23-0414	CLIP CV-70S	18	18	18	18

# 16. ACCESSORIES

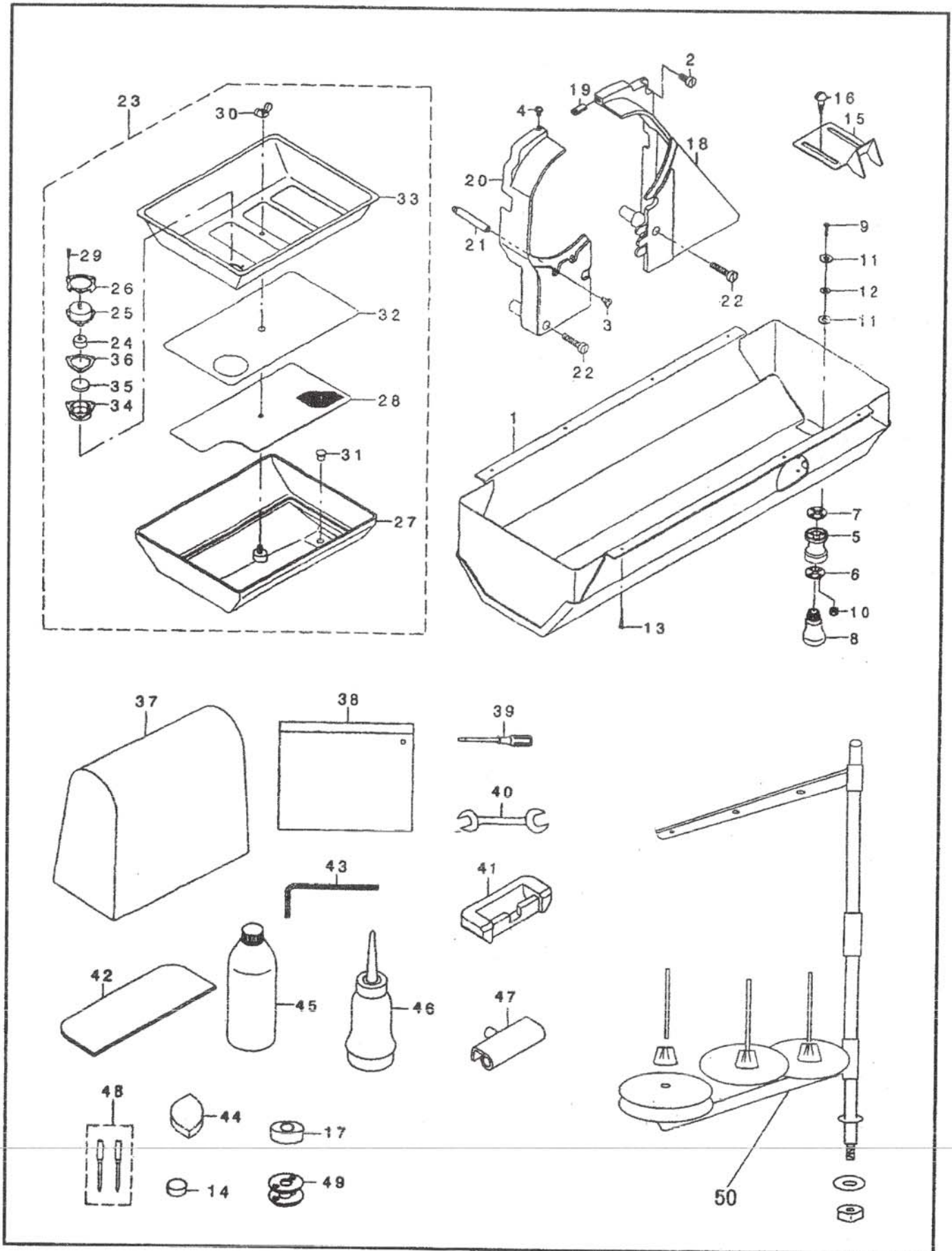



## 16. ACCESSORIES

REF NO	PART NO	DESCRIPTION	Qty			
			1560N	1510N	1560N-7	1510N-7
1	23-2001	OIL RESERVOIR ASM	1	1	1	1
2	23-2002	SCREW 15/64-28 L=14	1	1	1	1
3	23-2003	SCREW 11/64-40 L=7.8	1	1	1	1
4	23-2004	SCREW 11/64-40 L=6.5	1	1	1	1
5	23-2005	OIL MANAGEMENT	1	1	1	1
6	23-2006	OIL MANAGEMENT WASHER	1	1	1	1
7	23-2007	OIL SEAL	1	1	1	1
8	23-2008	OIL CAN	1	1	1	1
9	23-2009	SCREW M3 L=14	4	4	4	4
10	23-2010	NUT M3	4	4	4	4
11	23-2011	OIL REMOVING SETSCREW PACKING	8	8	8	8
12	23-2012	WASHER	4	4	4	4
13	23-2013	WOOD SCREW D=2.4 L=16	10	10	10	10
14	23-2310	FELT CUSHION	4	4	4	4
15	23-2015	BELT COVER C (JE)	1	1	1	1
16	23-2016	WOOD SCREW D=4.8 L=25	2	2	2	2
17	23-2311	RUBBER CUSHION	4	4	4	4
18	23-2018	BELT COVER (RIGHT)	1	1	1	1
19	23-2019	BELT COVER AUXILIARY PLATE	1	1	1	1
20	23-2020	BELT COVER (LEFT)	1	1	1	1
21	23-2021	BELT COVER SUPPORT A	1	1	1	1
22	23-2022	SCREW 15/64-28 L=30	2	2	2	2
23	23-2023	OIL TANK ASM	1	1	1	1
24	23-2024	FIL TER	1	1	1	1
25	23-2025	FIL TER CAP	1	1	1	1
26	23-2026	FIL TER PLATE	1	1	1	1
27	23-2027	OIL TANK	1	1	1	1
28	23-2028	COVER (LOWER)	1	1	1	1
29	23-2029	SCREW	3	3	3	3
30	23-2030	WING NUT M5	1	1	1	1
31	23-2031	RUBBER PLUG	1	1	1	1
32	23-2032	FIL TER	1	1	1	1
33	23-2033	COVER (REAR)	1	1	1	1
34	23-2034	FILTER CASE	1	1	1	1
35	23-2035	OIL RESERVOIR MAGNET	1	1	1	1
36	23-2036	FIL TER PACKING	1	1	1	1
37	05-0912	COVER	1	1	1	1
38	05-0901	ACCESSORY BAG ASM	1	1	1	1
39	05-0903	SCREW DRIVER LAPGE	1	1	1	1
40	23-2303	WRENCH(9×10)	1	1	1	1
41	23-2312	RUBBER SPACER	2	2	2	2
42	23-2321	SPACER	2	2	2	2
43	23-2318	WRENCH(3/32)	1	1	1	1
44	23-2320	CUSHION(A)	4	4	4	4
45	23-2304	NEW DEFRIX OIL NO. 2 (700CC)	1	1	1	1
46	23-2305	OIL ER	1	1	1	1
47	05-0914	HINGE ASM	2	2	2	2
48		NEEDLE SY3355 # 160-2	4	4	4	4
49	23-0635	BOBBIN	4	4	4	4
50	10-1009	THREAD STANDING DEVICE ASM	1	1	1	1

## 17. DL MECHANISM COMPONENTS (OPTIONAL PARTS)

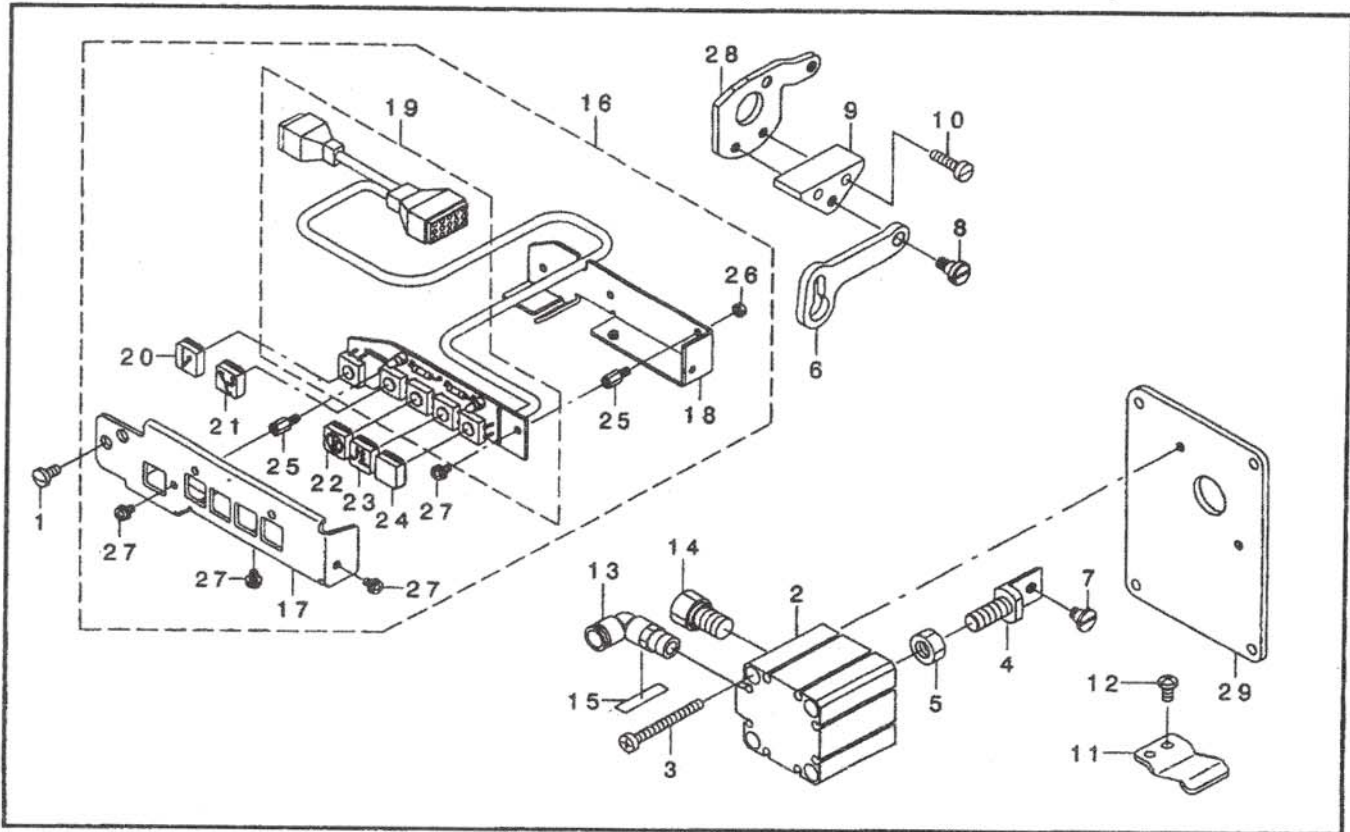

REF NO	PART NO	DESCRIPTION	Qty			
			1560N	1510N	1560N-7	1510N-7
1	39-2101	SCREW 11/64-40 L=7.8			2	2
2	39-2102	JIG CYLINDER				
3	48-1102	SCREW M4 L=40			1	1
4	48-1103	CYLYNDER CONNETING SCREW			2	2
5	48-1104	NUT M8			1	1
6	48-1105	MUTUAL VERTICAL LINK			1	1
7	48-1106	HINGE SCREW			1	1
8	48-1107	HINGE SCREW D=6 H=4.5			1	1
9	48-1108	MUTUAL VERTICAL LINK SPASER			1	1
10	48-1109	SCREW 11/64-40 L=16			1	1
11	48-1110	MUTUAL VERTICAL LINK SUPPORT			2	2
12	23-0105	SCREW 11/64-40 L=8			1	1
13	39-1910	ELBOW			2	2
14	39-0812	MUFFLER			1	1
15	39-1434	WIRE MARK (4)			1	1
16	39-2116	5RANGE SWITCH ASM			1	1
17	39-2117	SWITCH COVER			1	1
18	39-2118	SWITCH CIRCUIT FITTING BASE			1	1
19	39-2119	5RANGE SWITCH CIRCUIT ASM			1	1
20	39-2120	KEY TOP A			1	1
21	39-2121	KEY TOP B			1	1
22	39-2122	KEY TOP C			1	1
23	39-2123	KEY TOP D			1	1
24	39-2124	KEY TOP F			1	1
25	39-2125	SPACER			1	1
26	39-2126	NUT M3			4	4
27	39-2127	SCREW M3 L=6			3	3
28	48-0431	STOPPER PLATE B			4	4
29	48-0109	WINDOW PLATE E PACKING			1	1

## 18. DIRECT DRIVE MOTOR COMPONENTS

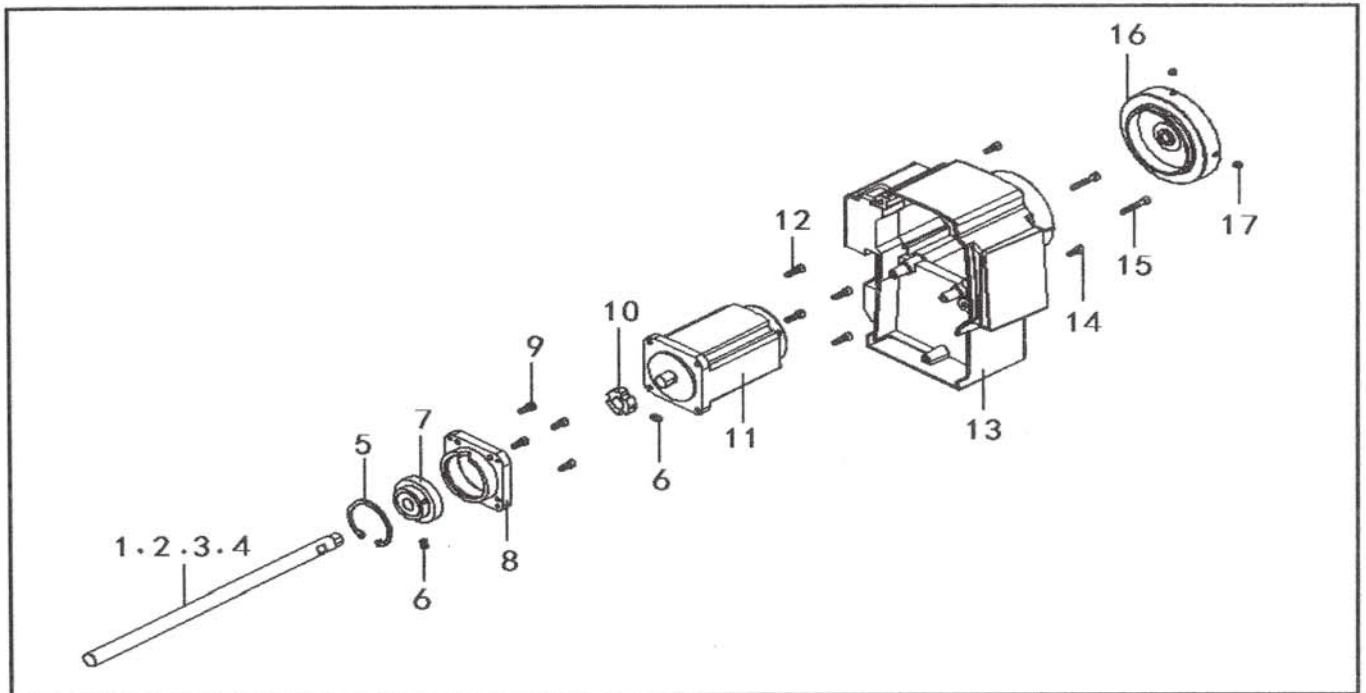



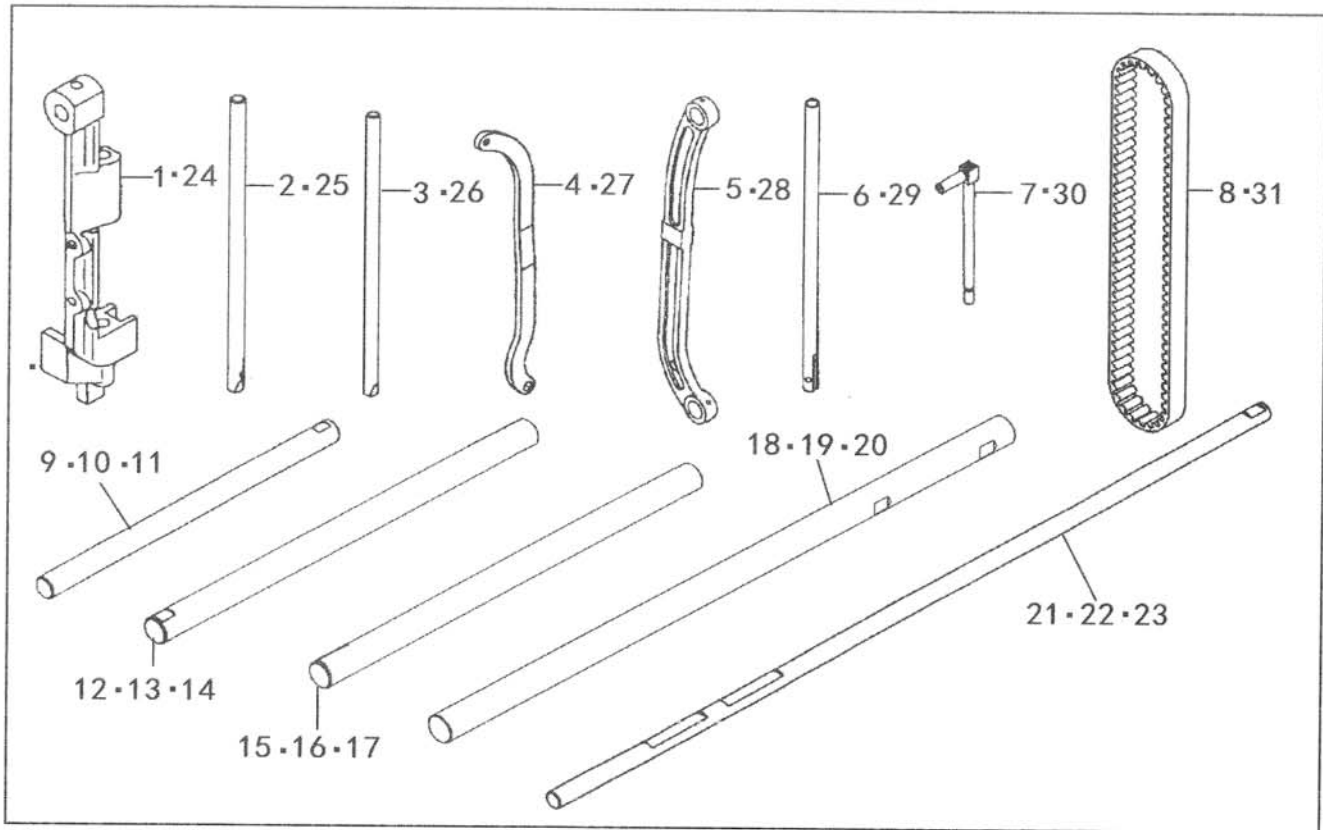

REF NO	PART NO	DESCRIPTION	Qty			
			1560D 1560D-7 1510D 1510D-7	1560D-L14 1560D-L14-7 1510D-L14 1510D-L14-7	1560D-L18 1560D-L18-7 1560D-L18H-7 1510D-L18 1510D-L18-7 1510D-L18H-7	1560D-L25 1560D-L25-7 1560D-L25H-7 1510D-L25 1510D-L25-7 1510D-L25H-7
1	23-0201D	UPPER SHAFT	1			
2	23-0201D-14	UPPER SHAFT		1		
3	23-0201D-18	UPPER SHAFT			1	
4	23-0201D-25	UPPER SHAFT				1
5	23-0275D	SPRING RETAINER	1	1	1	1
6	23-0276D	SCREW M5 L=16	4	4	4	4
7	23-0277D	COUPLER ASSEMBLY (LEFT)	1	1	1	1
8	23-0278D	MOTOR ASSEMBLY BASE	1	1	1	1
9	23-0279D	SCREW M6*0.75 L=10	4	4	4	4
10	23-0280D	COUPLER ASSEMBLY (RIGHT)	1	1	1	1
11	23-0281D	MOTOR	1	1	1	1
12	23-0279D	SCREW M5 L=16	4	4	4	4
13	23-0282D	CONTROL BOX	1	1	1	1
14	23-0283D	SCREW M5 L=12	2	2	2	2
15	23-0284D	SCREW M5 L=30	2	2	2	2
16	23-0285D	HANDWHEEL	1	1	1	1
17	23-0286D	SCREW M6 L=6	2	2	2	2





# 19. SPECIAL COMPONENTS FOR LONG AND HIGH ARM

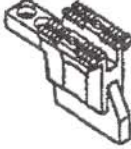

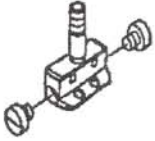
REF NO	PART NO	DESCRIPTION	Qty	备注
1	23-0301H	NEEDLE BAR FRAME	1	FOR HIGHARM L18/L25 MACHINE
2	23-0307H	NEEDLE BAR	1	FOR DOUBLE NEEDLE HIGH ARM L18/L25 MACHINE
3	25-0307H	NEEDLE BAR	1	FOR SINGLE NEEDLE HIGH ARM L18/L25 MACHINE
4	23-1119H	KNEE LIFTER CONNECTING PLATE	1	FOR HIGH ARM L18/L25 MACHINE
5	23-0520H	NEEDLE BAR FRAME ROD	1	FOR HIGH ARM L18/L25 MACHINE
6	23-0439H	PRESSER BAR	1	FOR HIGH ARM L18/L25 MACHINE
7	23-0424H	WALKING BAR	1	FOR HIGH ARM L18/L25 MACHINE
8	23-0225H	TIMING BELT	1	FOR HIGH ARM L18/L25 MACHINE
9	23-0401-L14	UPPER FEED SHAFT	1	FOR LONG ARM L14 MACHINE
10	23-0401-L18	UPPER FEED SHAFT	1	FOR LONG ARM L18 MACHINE
11	23-0401-L25	UPPER FEED SHAFT	1	FOR LONG ARM L25 MACHINE
12	23-0322-L14	ROCKING SHAFT	1	FOR LONG ARM L14 MACHINE
13	23-0322-L18	ROCKING SHAFT	1	FOR LONG ARM L18 MACHINE
14	23-0322-L25	ROCKING SHAFT	1	FOR LONG ARM L25 MACHINE
15	23-0512-L14	FEED ROCK SHAFT	1	FOR LONG ARM L14 MACHINE
16	23-0512-L18	FEED ROCK SHAFT	1	FOR LONG ARM L18 MACHINE
17	23-0512-L25	FEED ROCK SHAFT	1	FOR LONG ARM L25 MACHINE
18	23-0201-L14	UPPER SHAFT	1	FOR LONG ARM L14 MACHINE
19	23-0201-L18	UPPER SHAFT	1	FOR LONG ARM L18 MACHINE
20	23-0201-L25	UPPER SHAFT	1	FOR LONG ARM L25 MACHINE
21	23-0636-L14	LOWER SHAFT	1	FOR LONG ARM L14 MACHINE
22	23-0636-L18	LOWER SHAFT	1	FOR LONG ARM L18 MACHINE
23	23-0636-L25	LOWER SHAFT	1	FOR LONG ARM L25 MACHINE
24	23-0301H2	NEEDLE BAR FRAME	1	FOR HIGH ARM L14 MACHINE
25	23-0307H2	NEEDLE BAR	1	FOR DOUBLE NEEDLE HIGH ARM L14 MACHINE
26	25-0307H2	NEEDLE BAR	1	FOR SINGLE NEEDLE HIGH ARM L14 MACHINE
27	23-1119H2	KNEE LIFTER CONNECTING PLATE	1	FOR HIGH ARM L14 MACHINE
28	23-0520H2	NEEDLE BAR FRAME ROD	1	FOR HIGH ARM L14 MACHINE
29	23-0439H2	PRESSER BAR	1	FOR HIGH ARM L14 MACHINE
30	23-0424H2	WALKING BAR	1	FOR HIGH ARM L14 MACHINE
31	23-0225H2	TIMING BELT	1	FOR HIGH ARM L14 MACHINE

## 20. TABLE OF EXCHANGING CAUGE PARTS

Needle gauge Size	Throat Plate	Feed Dog	Presser Foot asm	Needle Clamp asm
				
	Parts No	Parts No	Parts No	Parts No
(1/8)	23-0136K	23-0542K	23-0455K	23-0311K
(3/16)	23-0136R	23-0542R	23-0455R	23-0311R
(1/4)	23-0136A	23-0542A	23-0455A	23-0311A
(5/16)	23-0136B	23-0542B	23-0455B	23-0311B
(3/8)	23-0136C	23-0542C	23-0455C	23-0311C
(1/2)	23-0136D	23-0542D	23-0455D	23-0311D
(5/8)	23-0136E	23-0542E	23-0455E	23-0311E
(3/4)	23-0136F	23-0542F	23-0455F	23-0311F
(7/8)	23-0136G	23-0542G	23-0455G	23-0311G
(1)	23-0136H	23-0542H	23-0455H	23-0311H
(1-1/8)	23-0136S	23-0542S	23-0455S	23-0311S
(1-1/4)	23-0136U	23-0542U	23-0455U	23-0311U

Needle gauge Size	Feed Foot asm	Bed Slide asm (Left)	Bed Slide asm (Right)
			
	Parts No	Parts No	Parts No
(1/8)	23-0451K	23-0140A	23-0142A
(3/16)	23-0451R		
(1/4)	23-0451A		
(5/16)	23-0451B		
(3/8)	23-0451C		
(1/2)	23-0451D	23-0140B	23-0142B
(5/8)	23-0451E		
(3/4)	23-0451F		
(7/8)	23-0451G	23-0140C	23-0142C
(1)	23-0451H		
(1-1/8)	23-0451S		
(1-1/4)	23-0451U		

