

*Since 1898*  
**CONSEW**®

CONSOLIDATED SEWING MACHINE CORP.

└ INDUSTRIAL SEWING & CUTTING EQUIPMENT

## Operator's Guide

255RBL-3

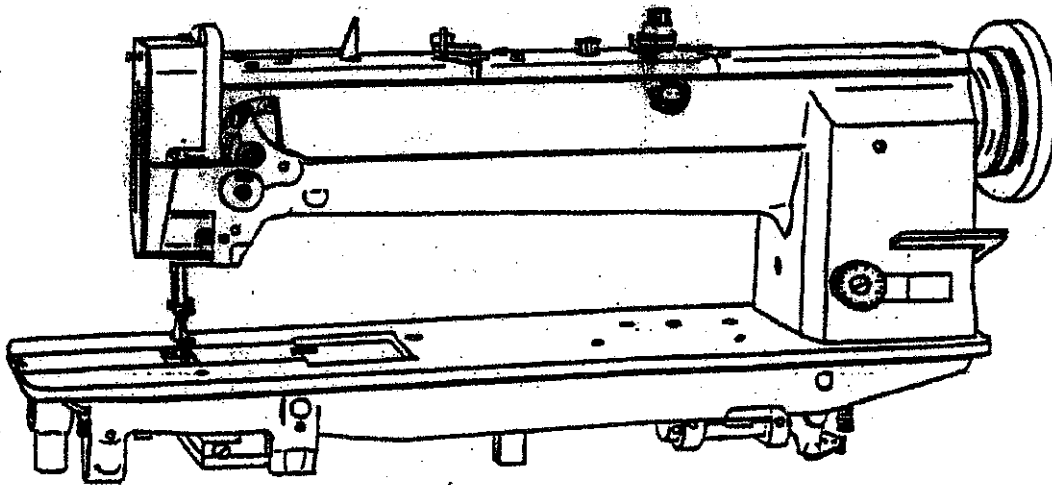

# 1. LUBRICATION AND OILING ADJUSTMENT

Before initially running the machine or after a prolonged idle period, the machine should be oiled sufficiently to insure that the necessary parts are well lubricated before starting any operation. The arrows in the following diagrams, Figures 1, 2 & 3 indicate these oiling points.

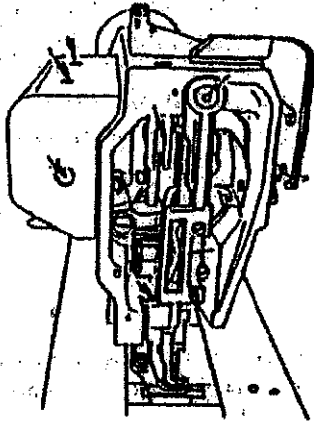

Fig. 1

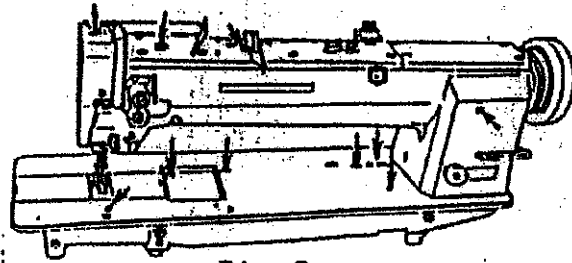

Fig. 2

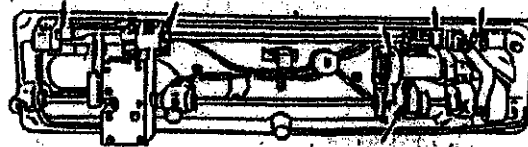
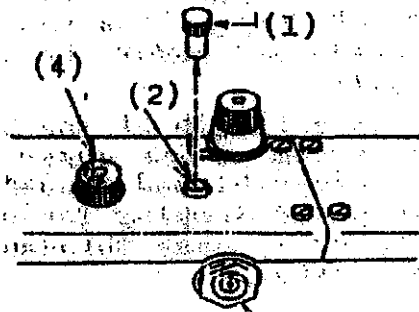

Fig. 3

## LUBRICATION TO THE OIL RESERVOIR IN THE ARM AND OILING ADJUSTMENT



(3) Fig. 4

## OILING TO THE HOOK

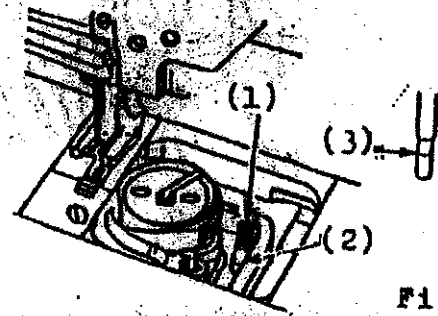

Fig. 5

1. Remove the oil stopper (1), pour the oil into the designated hole (2) until the oil gauge reaches full (3).
2. When operating the machine, push down the adjusting serrated nut (4) and turn it counter-clockwise as shown in Fig.4.
3. When not operating the machine, the oil adjusting nut (4) should be returned to the position before the oil reservoir was filled. Remove the oil from the reservoir until The gauge reaches the level shown in Fig. 5 arrow (3).

### OILING ADJUSTMENT FOR THE HOOK

Loosen the screw (1), to increase the oil flow, align the screw to mark on line (2) on the nut (3). To stop the oil flow, turn the nut (3) far enough to make the reference line vertical. Refer to Fig. 6

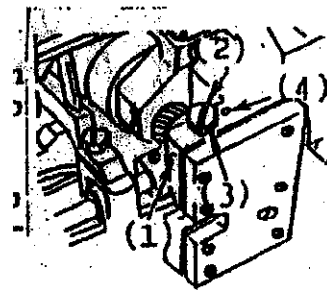

Fig.6

1. Move up the needle bar (1).
2. Insert the needle (2) into the needle bar as far as it will go with the long groove (3) of the needle facing the left. (in double needle machines grooves of the needles face each other on the inside.)
3. Tighten the screws (4).

### SETTING THE NEEDLE

1-Needle

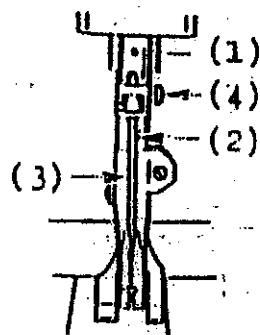

Fig.7

2-Needle

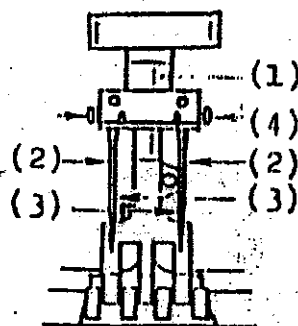

Fig.8

## REMOVING AND INSERTING THE BOBBIN

Open the slide plate (1), raise the latch (2) and remove the bobbin (3).

Insert the left twist threaded bobbin into the bobbin case and push down the latch (2).

3. Pass the bobbin thread through and into the slot (4) of the sewing hook and guide the thread between the bobbin case opener (5) and the top (6) of the sewing hook and draw the thread end under the tension spring (7).

4. Pull out a length of the bobbin thread (4-5 cm) to the upper end of the needle plate (8) and close the needle plate keeping enough clearance to pass through the bobbin thread.

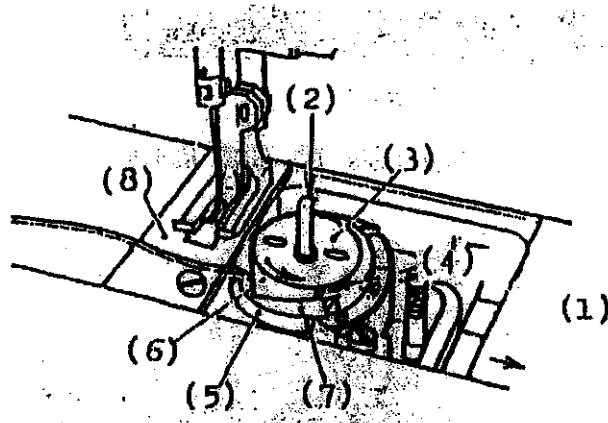
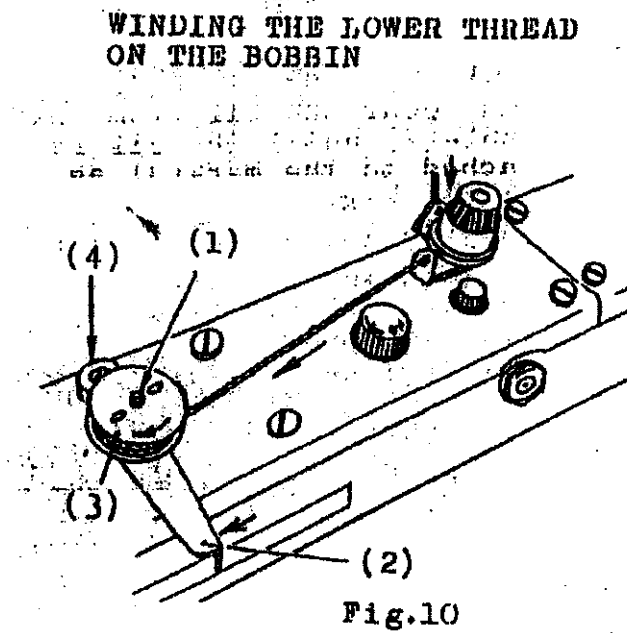

Fig. 9

## WINDING THE LOWER THREAD ON THE BOBBIN

1. Insert the bobbin onto the bobbin winder spindle (1).
  2. Pull the set lever (2) to the left, as far as it will go.
  3. Lead the thread as shown in Fig.10. Wind the thread on the bobbin clockwise several times as shown in Fig. 10.
  4. Winding operation should be done once the thread has tightened.
- \* Winding speed can be regulated by the adjusting collar (4).



# THREADING THE NEEDLE

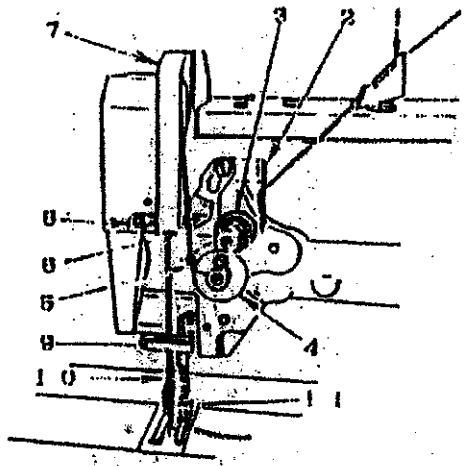

Fig.11

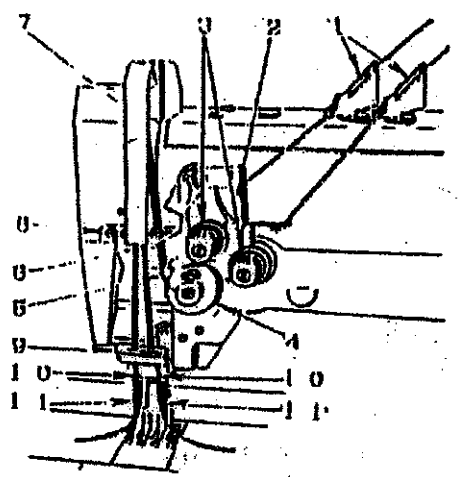

Fig.12

Raise the needle and advance the thread in numerical order from 1 to 11. (Fig. 11 & 12).

Thread needle

1-needle: from left to right.

2-needle: from inside to outside.

## REGULATING THE THREAD TENSION

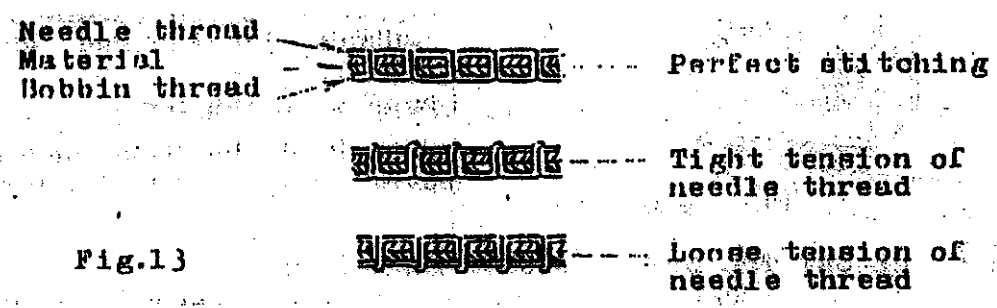

Fig.13

## 1. ADJUSTING THE UPPER THREAD TENSION

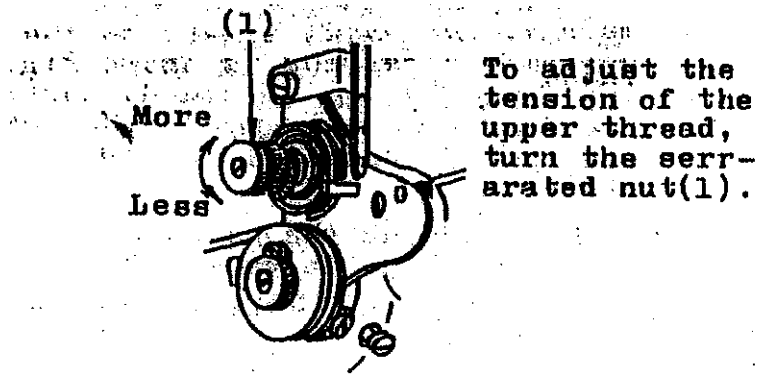

Fig.14

## 2. ADJUSTING THE LOWER THREAD TENSION

### 2. ADJUSTING THE LOWER THREAD TENSION

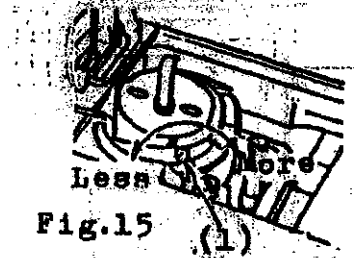

Fig.15

To adjust the tension of the lower thread, turn the adjusting screw(1).

# ADJUSTING THE PRESSURE OF THE PRESSER FOOT

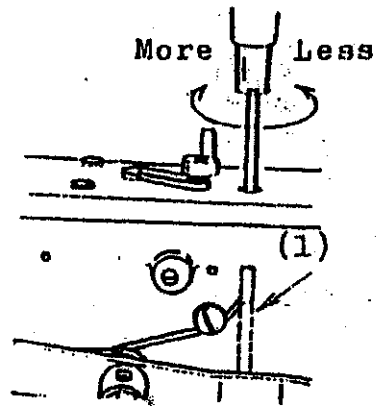

Fig.16.

To adjust this, turn the adjusting screw (1)

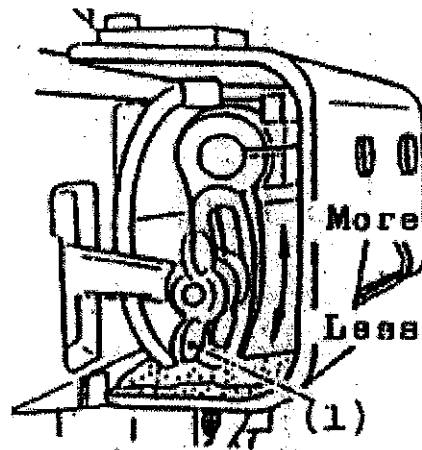

Fig.17



**Consolidated Sewing Machine Corp.**  
**Website: [www.consew.com](http://www.consew.com)**

**MAIN office**

131 W. 25th Street  
New York, NY 10001  
Tel: 212-741-7788  
Fax: 212-741-7787  
e-mail: [consew@att.net](mailto:consew@att.net)

**Miami, FL**

4013 N.W. 79th Avenue  
Miami, FL 33166  
Tel: 305-471-0200  
Fax: 305-471-0243  
e-mail: [miamisales@consew.com](mailto:miamisales@consew.com)

**Los Angeles, CA**

2320 South Hill Street  
Los Angeles, CA 90007  
Tel: 213-745-8844  
Fax: 213-745-8855  
e-mail: [lasales@consew.com](mailto:lasales@consew.com)