



CONSOLIDATED SEWING MACHINE CORPORATION  
131 WEST 25<sup>TH</sup> STREET, NEW YORK, NY 10001

**MODEL**  
**230, 230B**

**OPERATOR'S GUIDE**

# NOTES

1. Before you run the machine you must lubricate the take-up lever, the needle bar and other moving parts. Remove the face plate and apply two or three drops to each of the points designated by the arrows in Fig. 1.

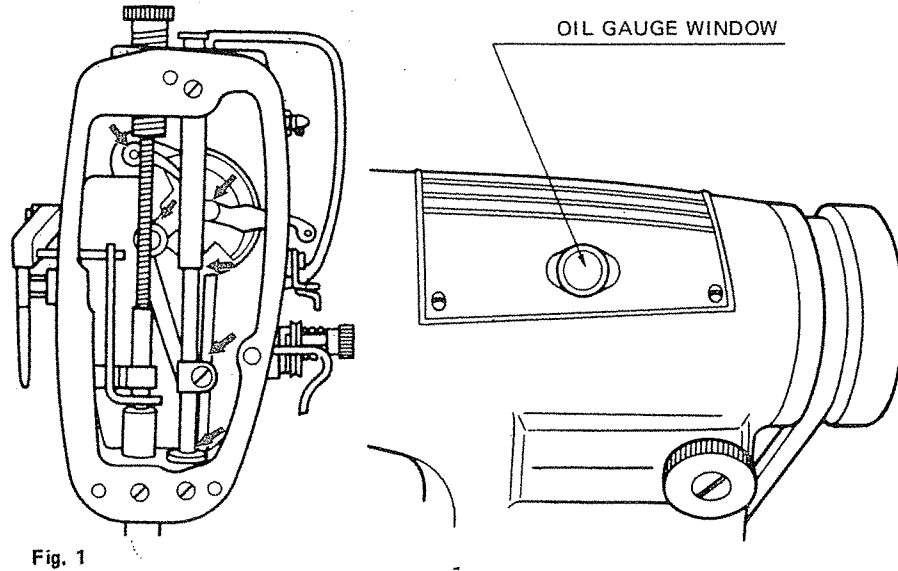

## CONTROL THE AMOUNT OF OIL

1. The oil supply for the rotating hook can be controlled through adjustment of valve "V" at the underside of the machine bed.
2. The oil supply for take-up lever can be adjusted by adjusting valve "AV". When mark "A" on adjusting valve "AV" is at A Position, the amount of oil supplied is at maximum level. When at Position B the oil flow is at minimum. Adjustments can be made at any point between "A" and "B".

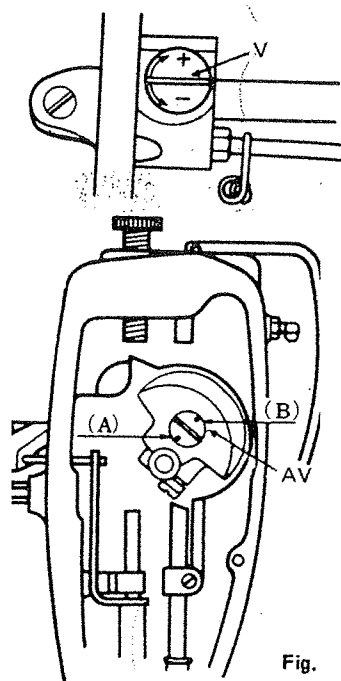

## SET-UP

Set the machine in place within the cutout, making sure that the space between the cut-out and the bed is equidistant all around the bed of the machine. See Fig. 2 below.

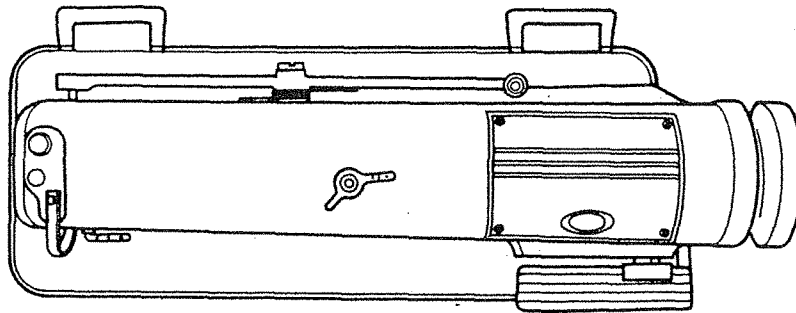

Fig. 2

## HOW TO WIND THE BOBBIN

1. Adjusting screw can be tightened or loosened to increase or decrease the amount of thread wound on bobbin.
2. When the thread is wound unevenly on the bobbin, adjust the thread guide to right or left according to the amount of thread.
3. When coated thread is wound on the bobbin, use less tension.

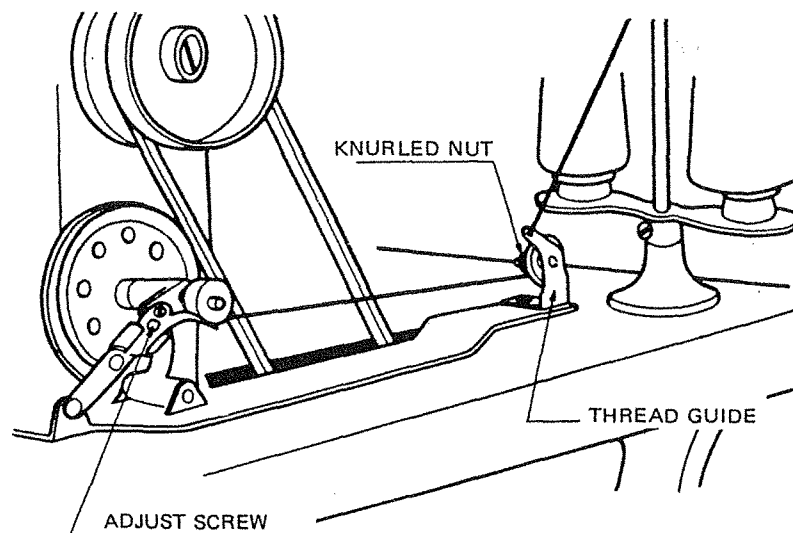

Fig. 3

## THREADING THE MACHINE

Turn hand wheel toward you until take-up lever reaches its highest point and pull thread from 1 to 13 as shown in Fig. 4. Pull thread 2-3 inches through the eye of the needle.

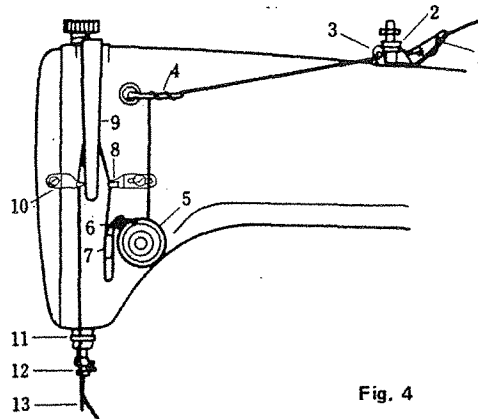

Fig. 4

## ADJUSTING THE HEIGHT OF THE PRESSER BAR

Remove the rubber plug from backside of the arm and adjust the height of presser bar by loosening the screw on presser bar guide bracket. (Fig. 6)

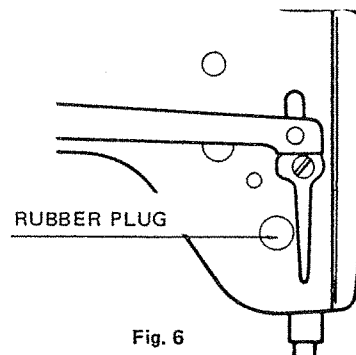

Fig. 6

## ADJUSTING THE TIMING BETWEEN THE NEEDLE AND ROTATING HOOK

1. When the needle is raised  $5/64$ " (2mm) from its lowest point, the point of the hook should align with the center of the needle.
2. In this case the height of needle should be adjusted by loosening the screw for the needle bar bracket so that the distance between the upper end of the needle's eye and the inside point of hook will be 1/16" (1.6mm).
3. The hook should be set so that the clearance between needles and the point of the hook should be about 0.003"- 0.005" (0.07—0.12mm).

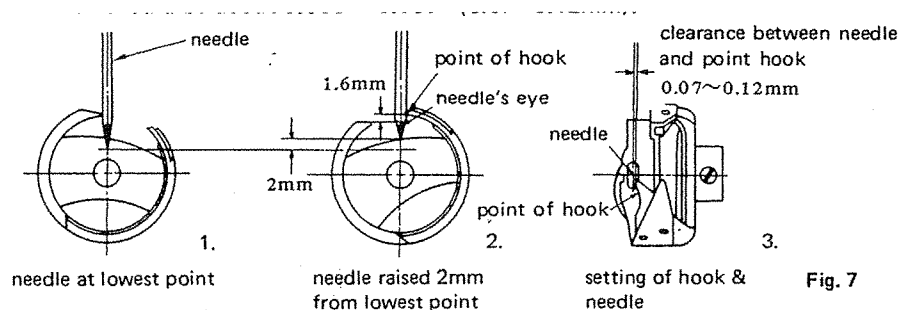

Fig. 7

## REGULATING THE TENSION

1. Turn serrated nut "N" on tension regulator to the right to increase tension and to the left to decrease it.
2. Check spring can be in action from 2.36"—3.15" (6—8mm). 20-25 g is the standard tension.

It is important for the check spring to go into action when the point of the rotating hook reaches its lowest point in relation to the hanging thread.

3. Standard position of thread guide is shown in Fig. 5.

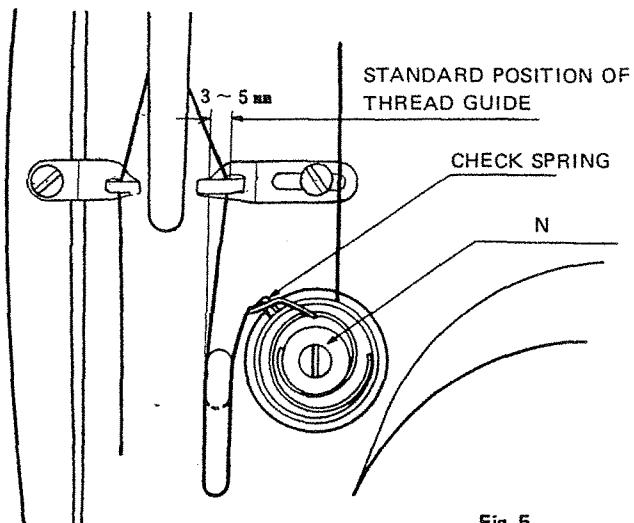

Fig. 5

**Consolidated Sewing Machine Corp.**  
**Website: [www.consew.com](http://www.consew.com)**

**MAIN office**

131 W. 25th Street  
New York, NY 10001  
Tel: 212-741-7788  
Fax: 212-741-7787  
e-mail: [consew@att.net](mailto:consew@att.net)

**Miami, FL**

4013 N.W. 79th Avenue  
Miami, FL 33166  
Tel: 305-471-0200  
Fax: 305-471-0243  
e-mail: [miamisales@consew.com](mailto:miamisales@consew.com)

**Los Angeles, CA**

2320 South Hill Street  
Los Angeles, CA 90007  
Tel: 213-745-8844  
Fax: 213-745-8855  
e-mail: [lasales@consew.com](mailto:lasales@consew.com)